

THIS DRAWING IS UNPUBLISHED. RELEASED FOR PUBLICATION
 © COPYRIGHT BY TYCO ELECTRONICS CORPORATION. ALL RIGHTS RESERVED.

| LOC | DIST | REVISIONS | | | | | |
|-----|------|-----------|-----|---------------|---------|-----|------|
| | | P | LTR | DESCRIPTION | DATE | DWN | APVD |
| DW | - | | A | RELEASED | 02AUG07 | JL | WK |
| | | | A1 | ECO-15-012216 | 05FEB16 | SZ | SZ |

NOTES:

- MATERIAL:
HOUSING: LCP WITH 30% GF, UL 94V-0, BLACK COLOR.
CONTACTS: PHOSPHOR BRONZE.
- FINISH:
CONTACTS: GOLD FLASH PLATED ON CONTACT AREA,
2.54um [100u"] MIN. MATTE-TIN PLATED ON SOLDER TAIL,
1.27um [50u"] MIN. NICKEL UNDERPLATED ALL OVER.
- REFLOW SOLDER CAPABLE TO 260°C PER TYCO TEST SPEC.
109-201, CONDITION B.

POST TYPE 1

OBSOLETE

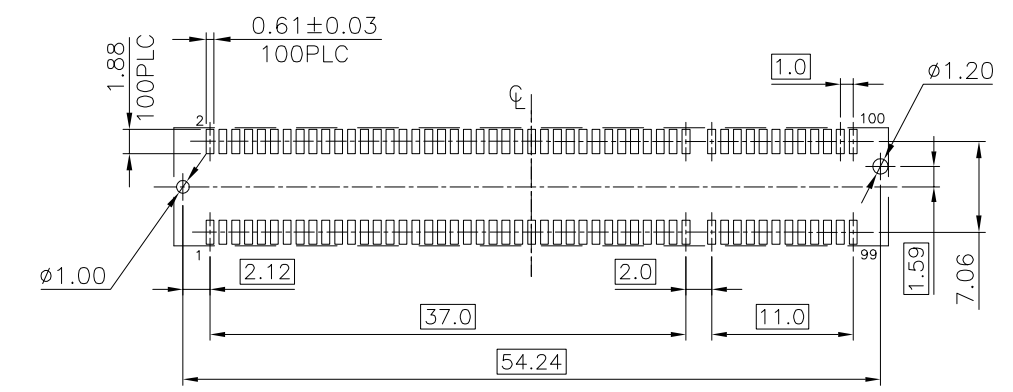
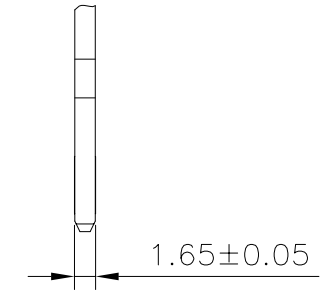
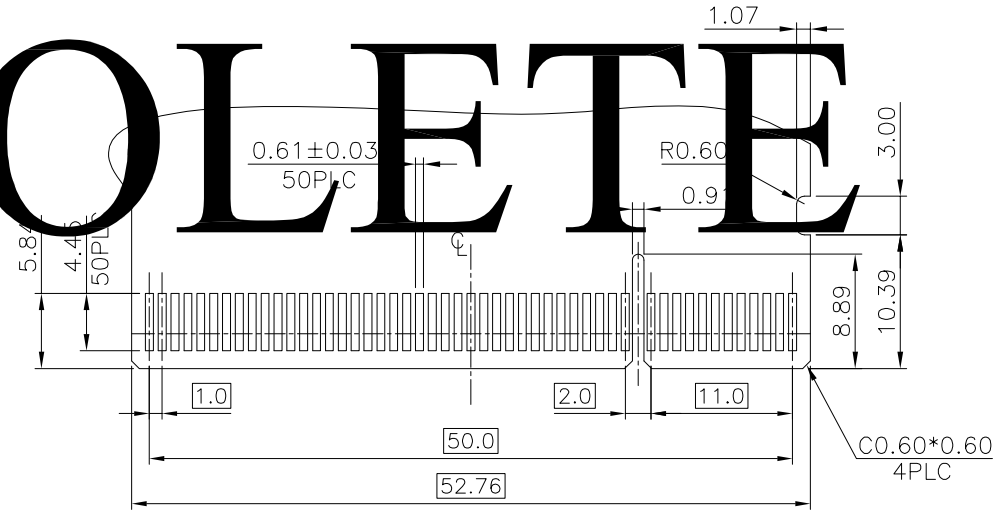
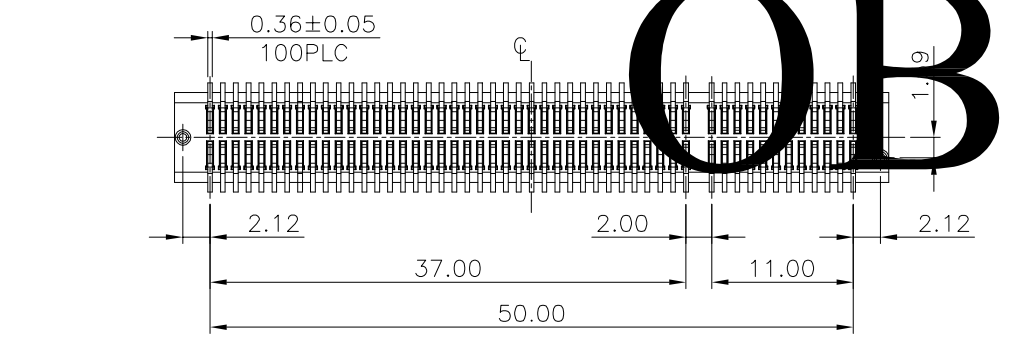
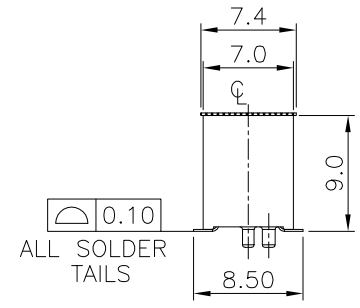
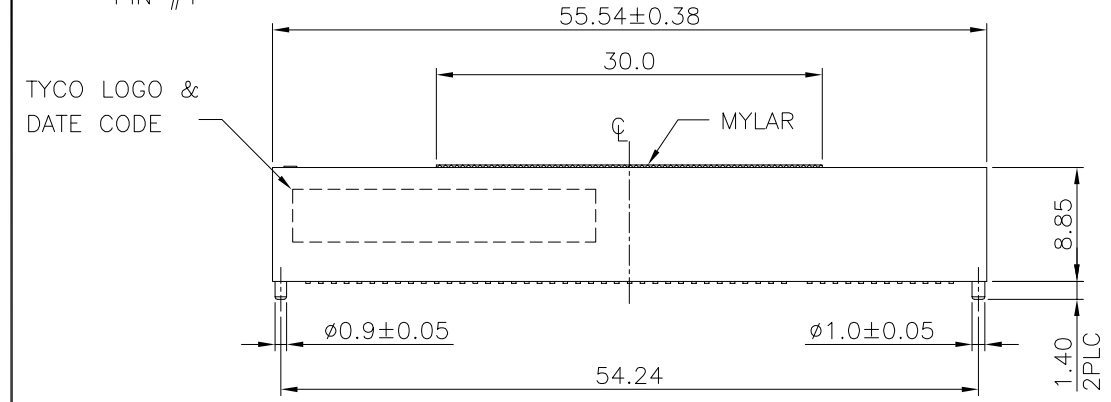
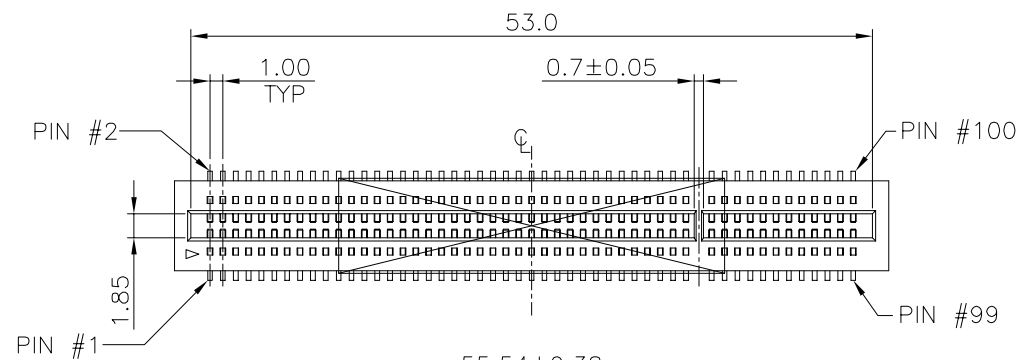

RECOMMENDED CARD PCB LAYOUT
 TOLERANCES ±0.05

OBSOLETE -1775520-1-
 PART NUMBER

RECOMMENDED PCB LAYOUT
 TOLERANCES ±0.05
 (TOP VIEW)

| | | | | | |
|--|--------------------|---------------------------|-----------|--|---------------|
| THIS DRAWING IS A CONTROLLED DOCUMENT. | | DWN J. LEE | 02AUG2007 | Tyco Electronics Corporation Taipei, Taiwan | |
| DIMENSIONS: MM | | CHK S. HOU | 02AUG2007 | NAME | |
| TOLERANCES UNLESS OTHERWISE SPECIFIED: | | APVD W.J. KE | 02AUG2007 | 1.0mm CARD EDGE, 100PIN, SMT, CONNECTOR | |
| 0 PLC ± - | 1 PLC ± 0.30 | PRODUCT SPEC | 108-57646 | SIZE | CAGE CODE |
| 2 PLC ± 0.20 | 3 PLC ± - | QUALIFICATION TEST REPORT | 501-57752 | DRAWING NO | RESTRICTED TO |
| 4 PLC ± - | ANGLES ± 3' | FINISH | SEE NOTE | A3 00779 | ©=1775520 |
| MATERIAL SEE NOTE | FINISH SEE NOTE | WEIGHT | 4.0GRAMS | SCALE | SHEET |
| CUSTOMER DRAWING | | | | 1 of 3 | REV A1 |

4

3

2

1

THIS DRAWING IS UNPUBLISHED. RELEASED FOR PUBLICATION
© COPYRIGHT BY TYCO ELECTRONICS CORPORATION. ALL RIGHTS RESERVED.

| LOC | DIST | REVISIONS | | | | | |
|-----|------|-----------|-----|--------------|------|-----|------|
| DW | - | P | LTR | DESCRIPTION | DATE | DWN | APVD |
| | | | | SEE SHEET 1. | | | |

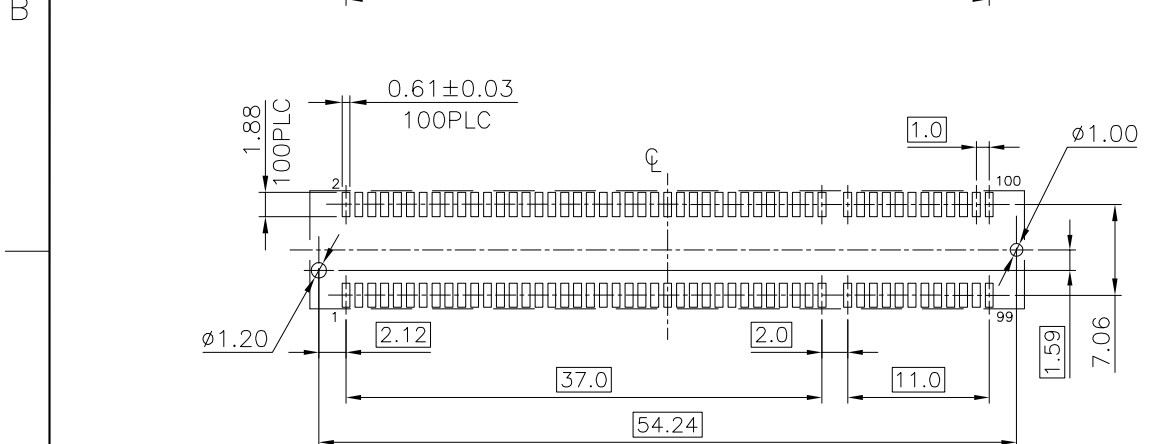
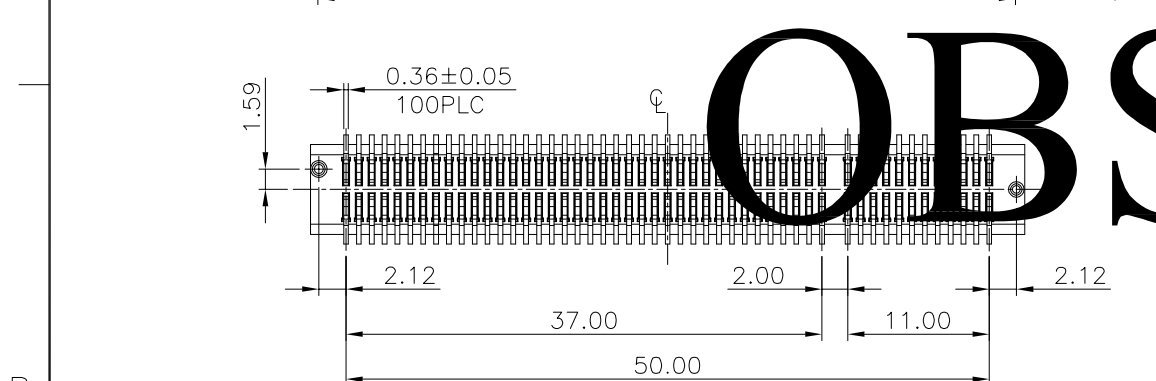
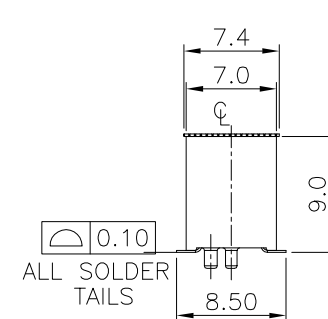
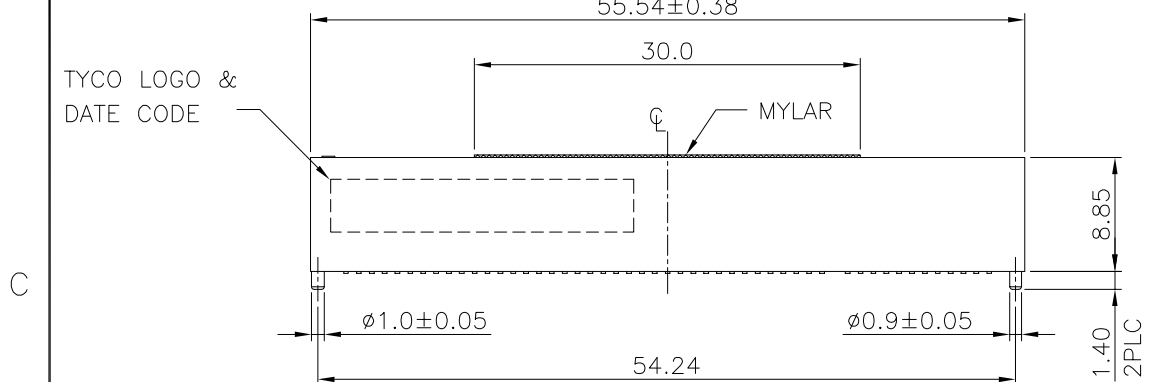
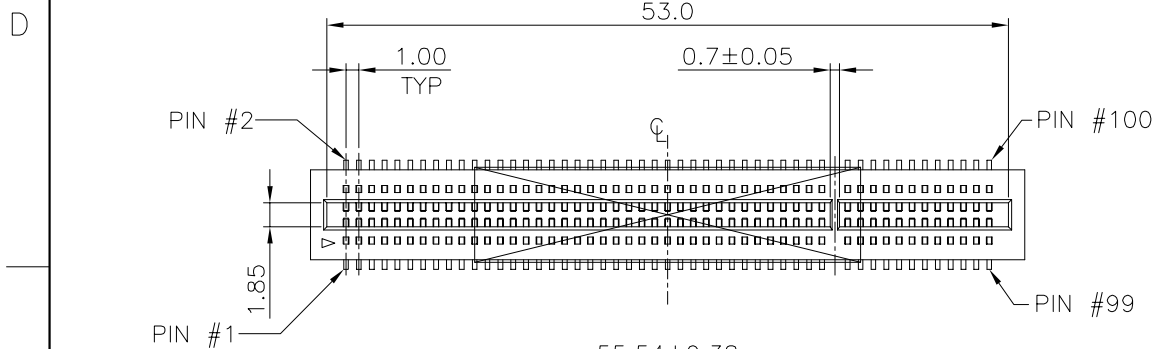

- NOTES:
- MATERIAL:
HOUSING: LCP WITH 30% GF, UL 94V-0, BLACK COLOR.
CONTACTS: PHOSPHOR BRONZE.
 - FINISH:
CONTACTS: GOLD FLASH PLATED ON CONTACT AREA,
2.54um [100u"] MIN. MATTE-TIN PLATED ON SOLDER TAIL,
1.27um [50u"] MIN. NICKEL UNDERPLATED ALL OVER.
 - REFLOW SOLDER CAPABLE TO 260°C PER TE TEST SPEC.
109-201, CONDITION B.

POST TYPE 2

OBSOLETE

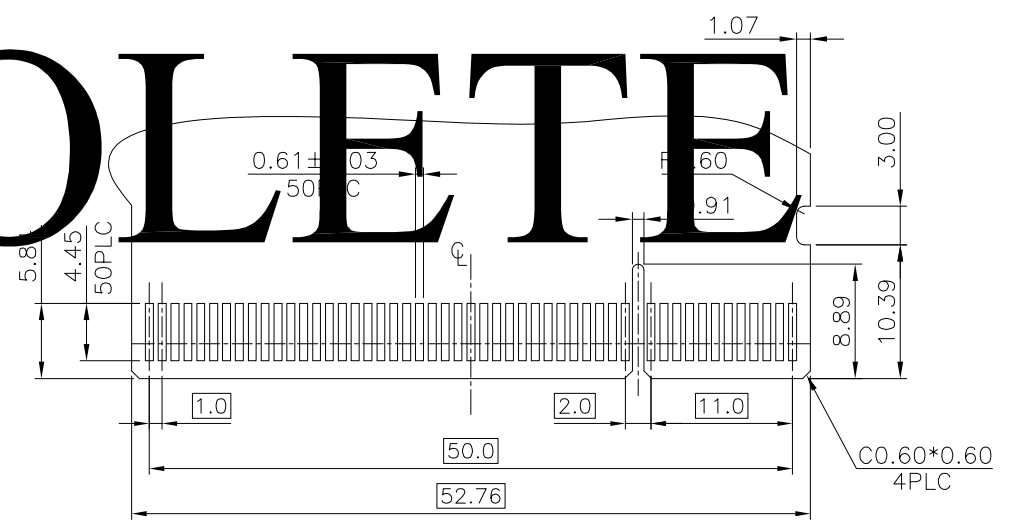

RECOMMENDED CARD PCB LAYOUT
TOLERANCES ±0.05

OBSOLETE 1-1775520-1
PART NUMBER

| | | | | | |
|--|--------------------|--|-----------|---|-------------------------|
| THIS DRAWING IS A CONTROLLED DOCUMENT. | | DWN J. LEE | 02AUG2007 | Tyco Electronics Corporation Taipei, Taiwan | |
| DIMENSIONS: MM | | CHK S. HOU | 02AUG2007 | NAME 1.0mm CARD EDGE, 100PIN, SMT, CONNECTOR | |
| TOLERANCES UNLESS OTHERWISE SPECIFIED: | | APVD W.J. KE | 02AUG2007 | SIZE A3 | |
| 0 PLC ± - | | PRODUCT SPEC 108-57646 | | CAGE CODE 00779 | DRAWING NO C=1775520 |
| 1 PLC ± 0.30 | | QUALIFICATION TEST REPORT 501-57752 | | RESTRICTED TO - | |
| 2 PLC ± 0.20 | | WEIGHT 4.0GRAMS | | SCALE - | SHEET 2 of 3 |
| 3 PLC ± - | | CUSTOMER DRAWING | | REV A1 | |
| 4 PLC ± - | | | | | |
| ANGLES ± 3' | | | | | |
| MATERIAL SEE NOTE | FINISH SEE NOTE | | | | |

THIS DRAWING IS UNPUBLISHED. RELEASED FOR PUBLICATION
 © COPYRIGHT BY TYCO ELECTRONICS CORPORATION. ALL RIGHTS RESERVED.

| LOC | DIST | REVISIONS | | | | | |
|-----|------|-----------|-----|--------------|------|-----|------|
| DW | - | P | LTR | DESCRIPTION | DATE | DWN | APVD |
| | | | | SEE SHEET 1. | | | |

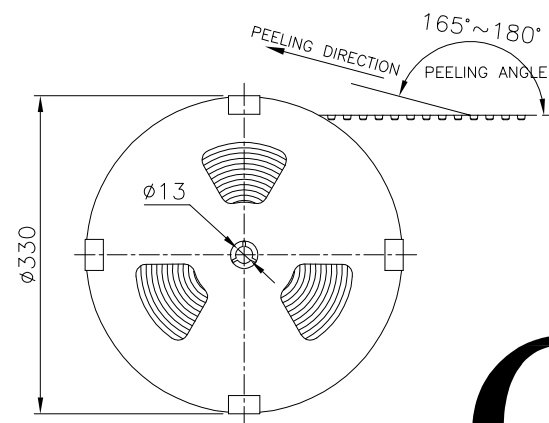
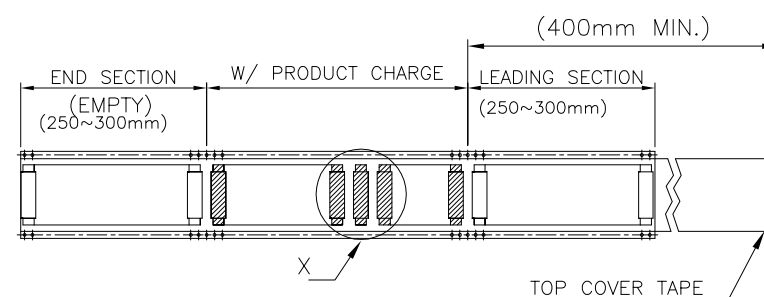
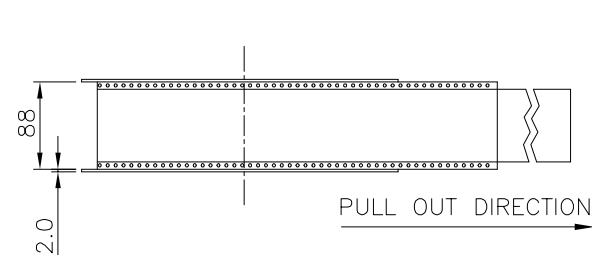

OBSOLETE

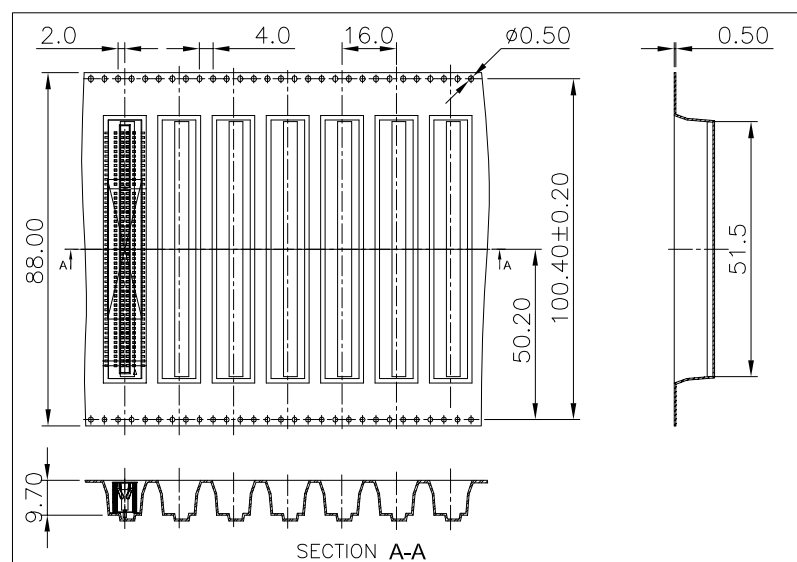
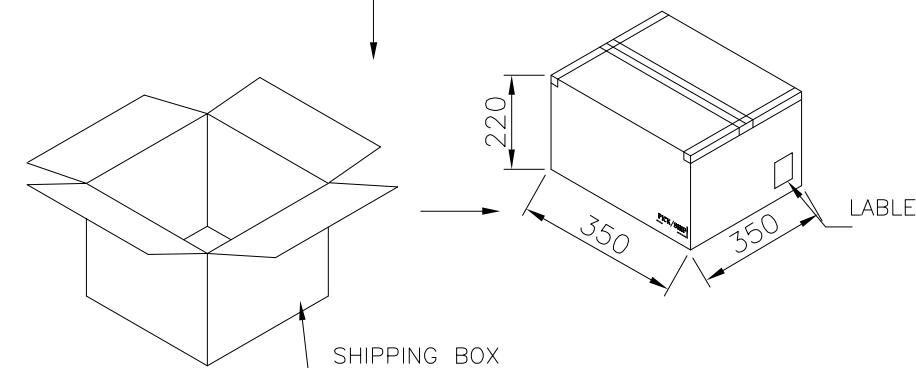
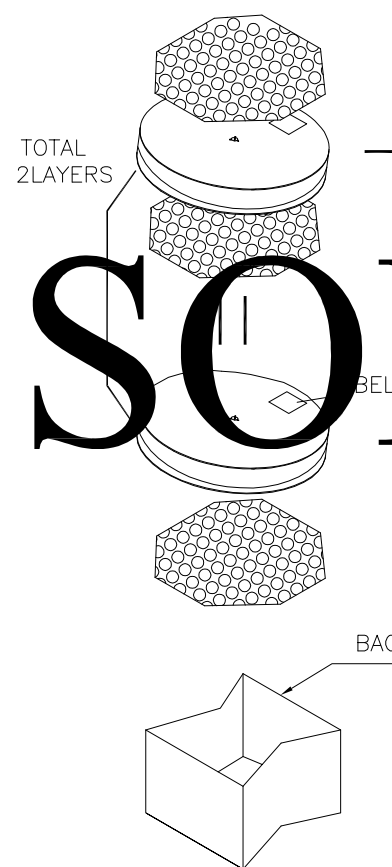

| | | | | |
|----------|----------|----------|----------|----------|
| 300 | 2 | 600 | 3.8 | 2.4 |
| PCS/TAPE | REEL/BOX | QUANTITY | G/W (KG) | N/W (KG) |

| | | | | |
|--|--|------------------------------|--|------------|
| THIS DRAWING IS A CONTROLLED DOCUMENT. | | DWN J. LEE 02AUG2007 | Tyco Electronics Corporation Taipei, Taiwan | |
| DIMENSIONS: MM | | CHK S. HOU 02AUG2007 | NAME | |
| TOLERANCES UNLESS OTHERWISE SPECIFIED: | | APVD W.J. KE 02AUG2007 | 1.0mm CARD EDGE, 100PIN, SMT, CONNECTOR | |
| 0 PLC ± - | | PRODUCT SPEC | SIZE | |
| 1 PLC ± - | | APPLICATION SPEC | CAGE CODE | DRAWING NO |
| 2 PLC ± - | | WEIGHT | A300779 | C=1775520 |
| 3 PLC ± - | | CUSTOMER DRAWING | RESTRICTED TO | - |
| 4 PLC ± - | | SCALE | SHEET | REV |
| ANGLES ± - | | - | 3 of 3 | A1 |
| FINISH | | - | | |