

REF. -49 OPT. SCREW
(WHERE APPLICABLE)

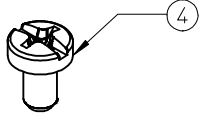

REF. -50 OPT. SCREW
(WHERE APPLICABLE)

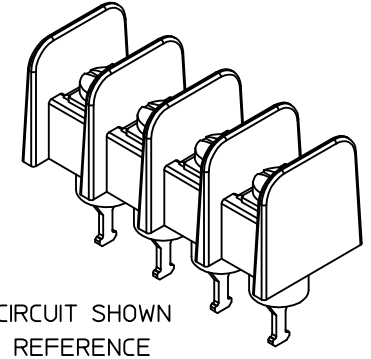
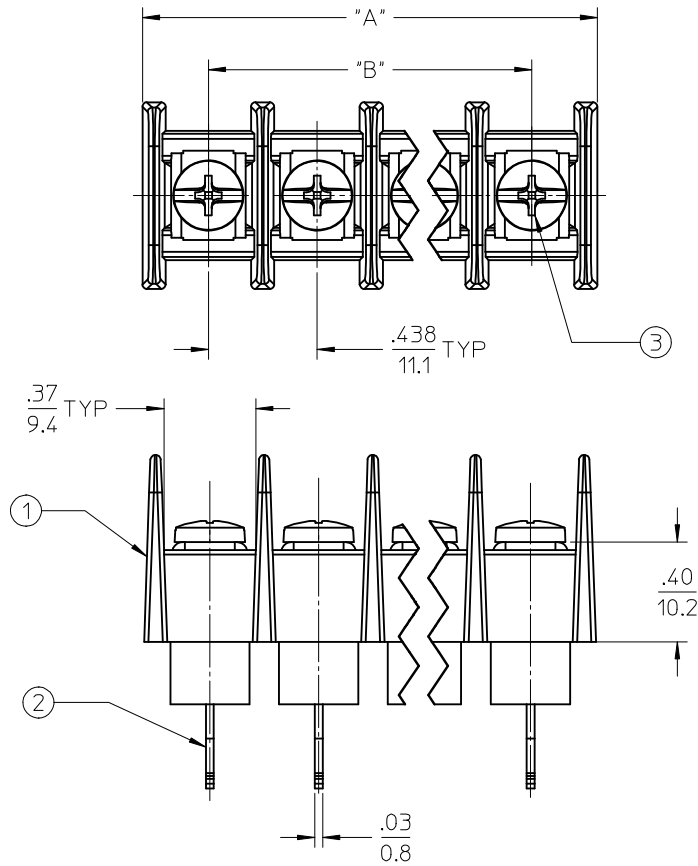
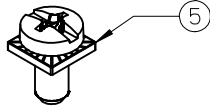

4 CIRCUIT SHOWN
AS REFERENCE

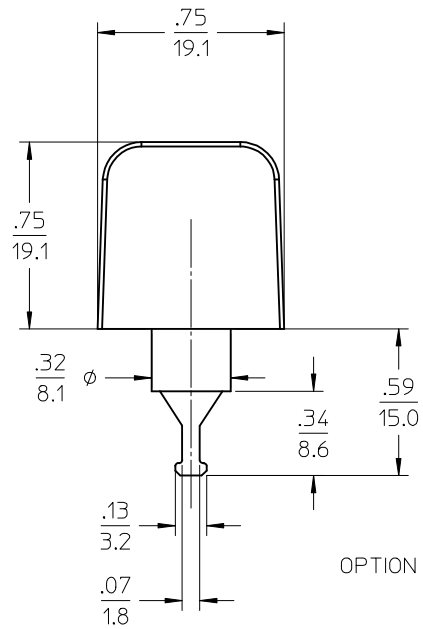

PART NUMBER LEGEND

73-2-XX-XX

SERIES
TERMINAL STYLE
CIRCUIT QTY (2 TO 30)
OPTION (-49 BRASS,PHIL/SLOT SCREW)
(-50 CLAMP WASHER,PHIL/SLOT SCREW)
(-C NO MOUNTING ENDS)

NOTES:

1. MATERIAL: SEE TABLE.
2. FINISHES: SEE TABLE.
3. PRODUCT SPECIFICATION: PS-38730-001.
4. "XX" REFERS TO THE QTY OF CIRCUITS.
5. ASSEMBLY IS RoHS COMPLIANT.

ITEM	QTY.	DESCRIPTION	MATERIAL	FINISH
5	XX	SCREW #6-32X.250 PAN PHS LZN/BR/STEEL -50	STEEL	ZINC
4	XX	SCREW #6-32X.250 BHD PHS LN/BRASS LUBE -49	BRASS	NICKEL
3	XX	SCREW #6-32X.250 BHD PHS LZN/STEEL LUBE	STEEL	ZINC
2	XX	TERM TURRET 6C SN/B	BRASS	TIN
1	1	SR BTS INSUL MO C	POLYESTER (PBT)	BLACK

RELEASED
EC NO: IPC2016-0008
DRAWN: SVMURTHY 2015/07/08
CHKD: RSTONE 2015/07/08
APPR: JFMURPHY 2016/07/11

QUALITY SYMBOLS
▽/0
▽/0
▽/0

GENERAL TOLERANCES (UNLESS SPECIFIED)

	mm	INCH
4 PLACES	± ---	± ---
3 PLACES	± ---	± .005
2 PLACES	± 0.13	± .01
1 PLACE	± 0.3	± ---
0 PLACE	± ---	± ---

ANGULAR ± 2°
DRAFT WHERE APPLICABLE
MUST REMAIN WITHIN DIMENSIONS

DIMENSION STYLE
IN/MM

DRAWN BY	DATE
SVMURTHY	2015/07/08
CHECKED BY	DATE
RSTONE	2015/07/08
APPROVED BY	DATE
JFMURPHY	2016/07/11

MATERIAL NO.
SEE SHEET 2

SCALE 2:1
DESIGN UNITS INCH
THIRD ANGLE PROJECTION

TITLE
11.13MM [.438"] SR BTS ASSY, INSULATED TURRET TERM, NO MTG ENDS

DOCUMENT NO. SD-38730-3302
SHEET NO. 1 OF 2

THIS DRAWING CONTAINS INFORMATION THAT IS PROPRIETARY TO MOLEX INCORPORATED AND SHOULD NOT BE USED WITHOUT WRITTEN PERMISSION

10 9 8 7 6 5 4 3 2 1

# OF CIRCUITS "XX"	DIM. "A"		DIM. "B"	
	in	mm	in	mm
02	.97	25	.438	11.13
03	1.40	36	.876	22.24
04	1.84	47	1.313	33.35
05	2.28	58	1.751	44.46
06	2.72	69	2.188	55.58
07	3.15	80	2.626	66.69
08	3.59	91	3.063	77.80
09	4.03	102	3.501	89.91
10	4.47	113	3.938	100.03
11	4.90	125	4.376	111.14
12	5.34	136	4.813	122.25
13	5.78	147	5.251	133.36
14	6.22	158	5.688	144.48
15	6.65	169	6.126	155.59
16	7.09	180	6.563	166.70
17	7.53	191	7.001	177.81
18	7.97	202	7.438	188.93
19	8.40	213	7.876	200.04
20	8.84	225	8.313	211.15
21	9.28	236	8.751	222.26
22	9.72	247	9.188	233.38
23	10.15	258	9.626	244.49
24	10.59	269	10.063	255.60
25	11.03	280	10.501	266.71
26	11.47	291	10.938	277.83
27	11.90	302	11.376	288.94
28	12.34	313	11.813	300.05
29	12.78	325	12.251	311.16
30	13.22	336	12.688	322.28

RELEASED EC NO: ICG2016-0008 DRAWN: SVMURTHY 2015/07/08 CHKD: RSTONE 2015/07/08 APPR: JFMURPHY 2016/07/11 REV A	QUALITY SYMBOLS $\nabla \sqrt{Z}=0$ $\nabla \sqrt{Z}=0$ $\nabla \sqrt{Z}=0$	GENERAL TOLERANCES (UNLESS SPECIFIED)		DIMENSION STYLE IN/MM		SCALE 2:1	DESIGN UNITS INCH	THIRD ANGLE PROJECTION		
		4 PLACES \pm --- \pm --- 3 PLACES \pm --- \pm .005 2 PLACES \pm 0.13 \pm .01 1 PLACE \pm 0.3 \pm --- 0 PLACE \pm --- \pm ---	mm INCH	DRAWN BY SVMURTHY	DATE 2015/07/08	TITLE 11.13MM [.438"] SR BTS ASSY, INSULATED TURRET TERM, NO MTG ENDS				
		ANGULAR \pm 2 ° DRAFT WHERE APPLICABLE MUST REMAIN WITHIN DIMENSIONS		CHECKED BY RSTONE	DATE 2015/07/08	APPROVED BY JFMURPHY				DATE 2016/07/11
				MATERIAL NO. 387303302	DOCUMENT NO. SD-38730-3302		SHEET NO. 2 OF 2		THIS DRAWING CONTAINS INFORMATION THAT IS PROPRIETARY TO MOLEX INCORPORATED AND SHOULD NOT BE USED WITHOUT WRITTEN PERMISSION	

9 8 7 6 5 4 3 2 1