

MODEL NUMBER  
ADT-2596-MF-TNC-02

NOTES:

1.0 MATERIALS:

- 1.1 HOUSINGS & COUPLING NUT: STAINLESS STEEL PER ASTM-A582, TYPE 303.
- 1.2 CENTER CONTACT: BERYLLIUM COPPER ROD ALLOY C172, PER ASTM-B196.
- 1.3 DIELECTRIC: PTFE FLOUROCARBON PER ASTM-D1457.

2.0 PLATING:

- 2.1 HOUSINGS & COUPLING NUT: PASSIVATED PER MIL-F-14072 AND QQ-P-35.
- 2.2 CENTER CONTACT: GOLD PER MIL-G-45204, TYPE II, CLASS 2.

3.0 ELECTRICAL SPECIFICATIONS:

- 3.1 FREQUENCY RANGE: DC to 18.0 GHz
- 3.2 VSWR (MAX):
  - DC to 4.0 GHz: 1.05:1
  - 4.0 to 8.0 GHz: 1.10:1
  - 8.0 to 18.0 GHz: 1.15:1
- 3.3 IMPEDANCE: 50 OHMS

4.0 MARKING: MARK UNIT AS SHOWN

5.0 DIMENSIONS IN PARENTHESIS ARE IN MILLIMETERS.

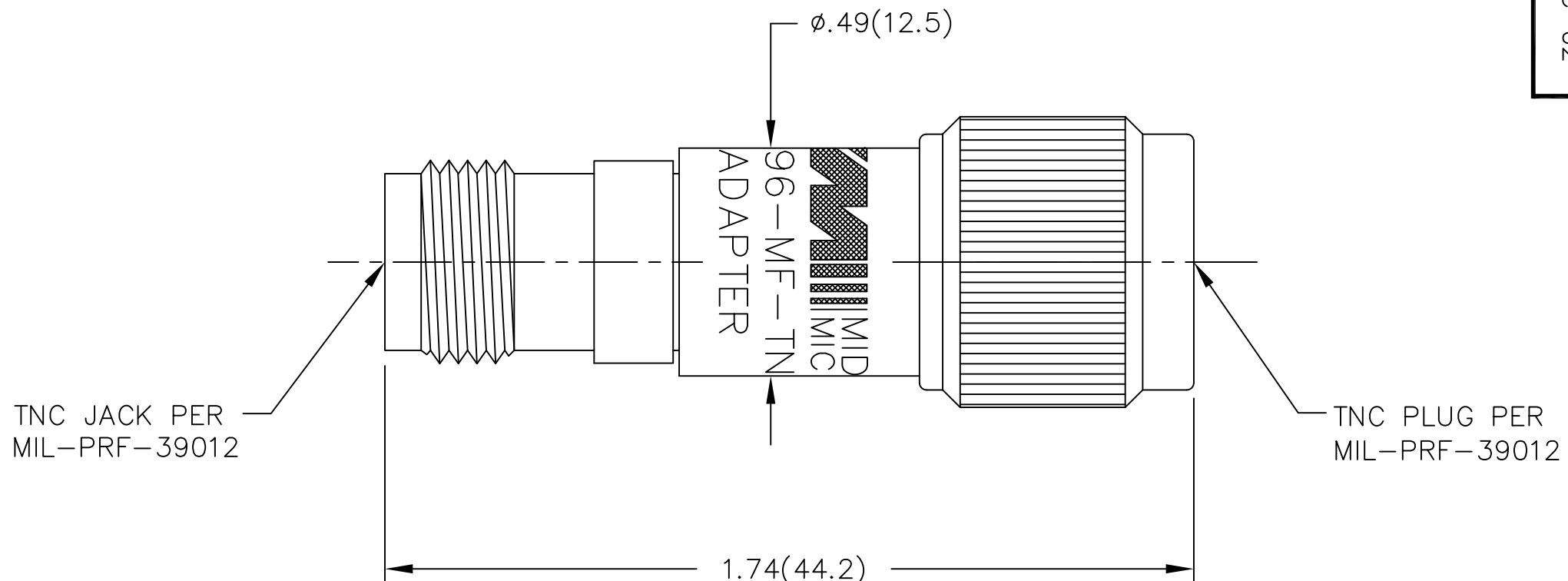

DWG. NO. WAS: 2392-01-00

REV.	DESCRIPTION	DATE
-	RELEASED	2/10/79
A	ECR 10356	7/12/93
B	ECN 12849	8/12/93
C	ECN 13908	9/8/94
C1	ADDED TITLEBLOCK	3/10/05
D	ECO 23383	3/14/11

NOTICE: The information contained in this drawing is proprietary and must not be used without the permission of Emerson Network Power.		CAGE CODE <b>34078</b>	<b>MIDWEST MICROWAVE</b>	
UNLESS OTHERWISE NOTED DIMENSIONS ARE IN INCHES AND TOLERANCES ARE: 3 PLACE DECIMALS ±.005 2 PLACE DECIMALS ±.02 FRACTIONS ±1/64 PARALLELITY: T.I.R. _____ FLATNESS: T.I.R. _____ CONCENTRICITY: T.I.R. _____ ANGLES AND PERPENDICULARITY: ±1'				TITLE  ADAPTER TNC PLUG TO TNC JACK OUTLINE DRAWING
DRAWN/DATE M.HOLLMAN 8/12/93		ENG./DATE A.OSGA 8/13/93		DRAWING NUMBER ADT-2596-MF-TNC-02-01
CHECKED/DATE A.BEATTY 8/13/93		APPROVED/DATE		REV. D
SCALE: 5=1		SHEET 1 of 1		