

DRAWING REVISIONS			
REV	DOCUMENT	APP	DATE
A	CCS	JW	-

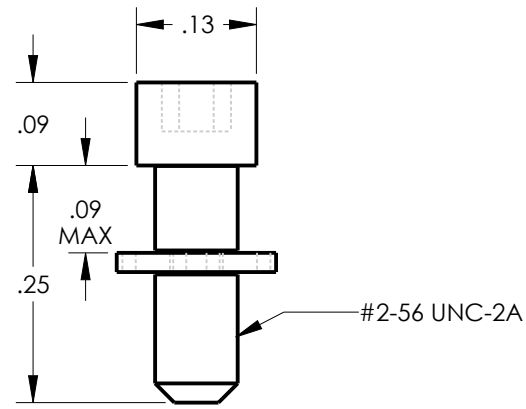

Figure 1

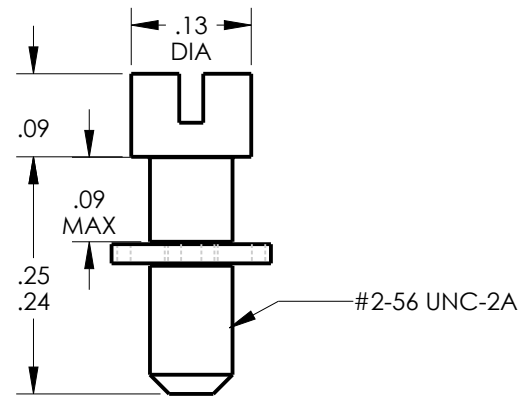

Figure 3

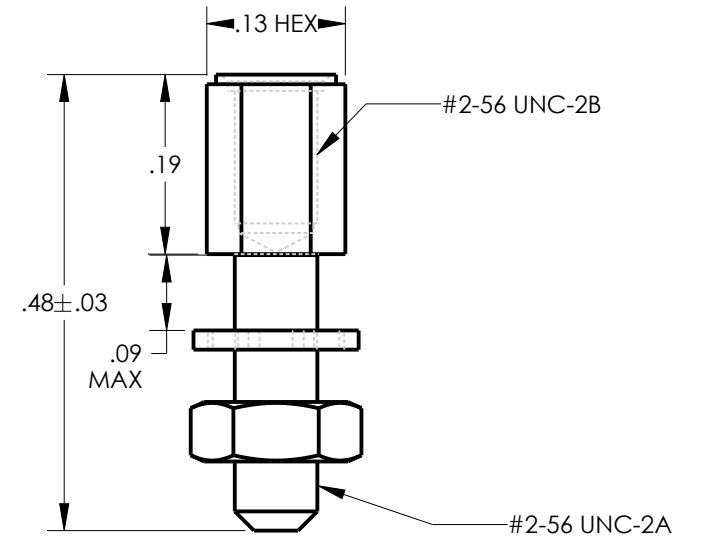

Figure 5

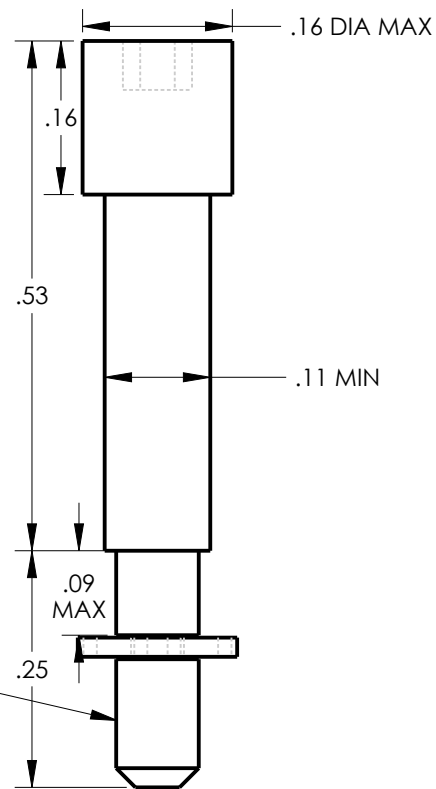

Figure 2

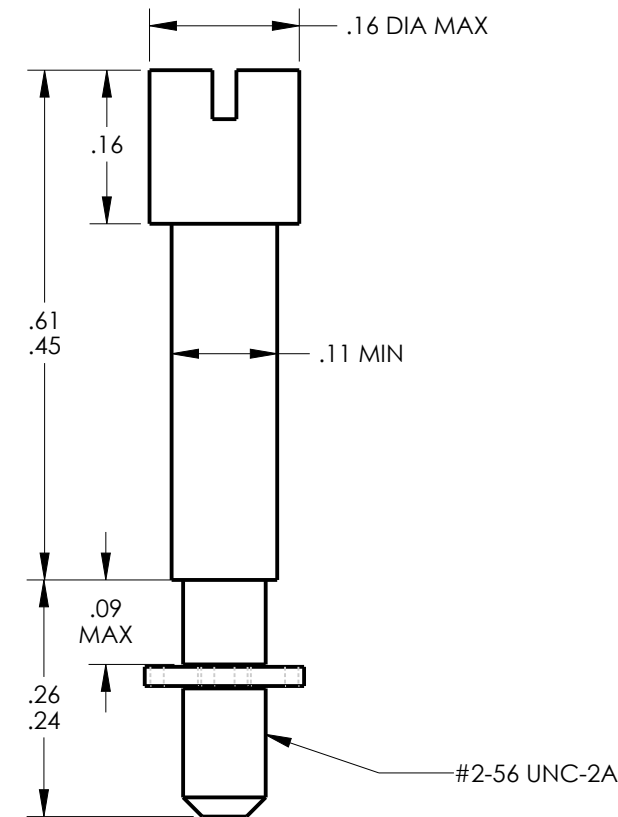

Figure 4

NOTES:
MATERIAL :
JACKSCREW: NONMAGNETIC CORROSION RESISTANT STEEL,
MINIMUM TENSILE STRENGTH OF 125,000PSI.
JACKPOST AND NUT: CORROSION RESISTANT STEEL
IN ACCORDANCE WITH ASTM A484/A484M AND
EITHER ASTM A276 OR ASTM A582/A582M,
PASSIVATED IIN ACCORDANCE WITH SAE-AMS2700
CLIP AND WASHERS: CORROSION RESISTANT STEEL
IN ACCORDANCE WITH ASTM A484/A484M,
PASSIVATED IIN ACCORDANCE WITH SAE-AMS2700.

ORDER INFORMATION

TYPE	STYLE	SCREWHEAD	THREAD	DURACON PART NO.	Figure
JACKSCREW	LOW POST	RECESSED HEX	#2/56	DCJS9-51HLP	1
JACKSCREW	HIGH POST	RECESSED HEX	#2/56	DCJS9-51H	2
JACKSCREW	LOW POST	SLOTTED	#2/56	DCJS9-51SLP	3
JACKSCREW	HIGH POST	SLOTTED	#2/56	DCJS9-51S	4
JACKPOST	--	--	#2/56	DCJP9-51	5

UNITS		PRO/E		CINCH	
ENGLISH INCHES		PRO/E		CINCH	
DO NOT SCALE DRAWING		DRAWN BY	DATE	TITLE	
UNLESS OTHERWISE SPECIFIED: ALL DIMENSIONS ARE IN INCHES		J. WARRAICH	-	JACKPOST AND JACKSCREW SALES DRAWING	
Fillet/Radii .02 MAX		DESIGN ENGINEER		MATERIAL	CONTROL SPEC NUMBER
TOLERANCES .X ± .1 .XX ± .01 .XXX ± .005 ANGULAR ± .5°		DESIGN ENGINEERING MGR.		MATERIAL SPEC NUMBER	FINISH
THIS DOCUMENT IS THE PROPERTY OF CINCH. NEITHER THIS DOCUMENT NOR ANY OF THE INFORMATION CONTAINED IN IT MAY BE DUPLICATED OR DISCLOSED WITHOUT PRIOR WRITTEN CONSENT OF CINCH.		MFG. ENGINEERING		CAD FILE NUMBER	DRAWING NUMBER
		QUALITY ASSURANCE		DCJ HARDWARE	DCJ HARDWARE
				CAGE IDENT NO.	SIZE
				71785	B
				SCALE	SHEET 1 OF 2
				5:1	

MODELED BY:
NAME

1700 FINLEY RD
LOMBARD, IL 60148

D

C

B

A

D

C

B

A

8

7

6

5

4

3

2

1

8

7

6

5

4

3

2

1

8

7

6

5

4

3

2

1

D

D

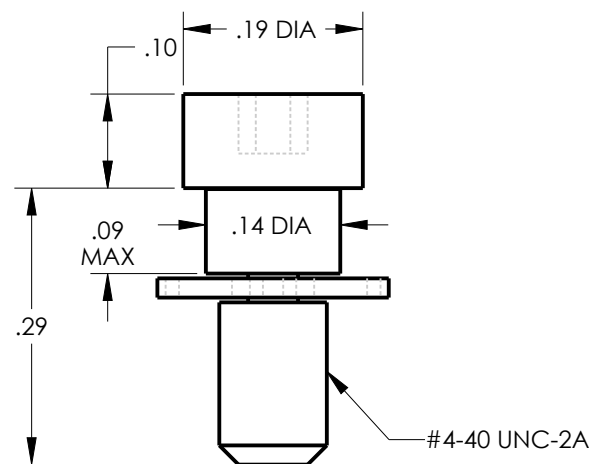

Figure 6

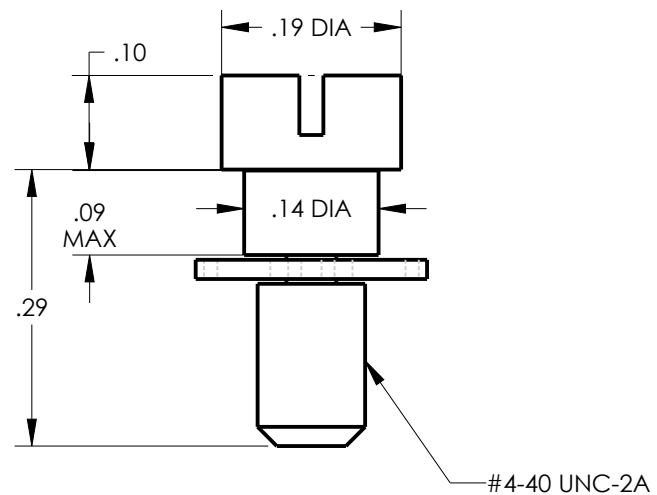

Figure 8

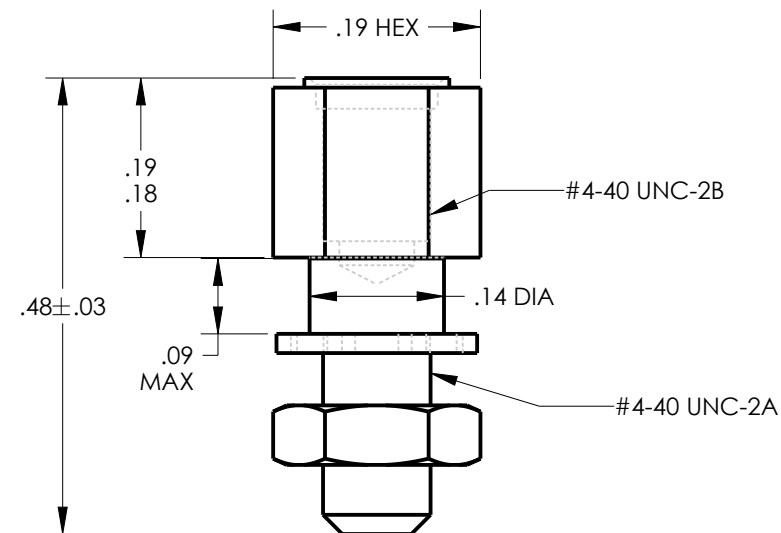

Figure 10

C

C

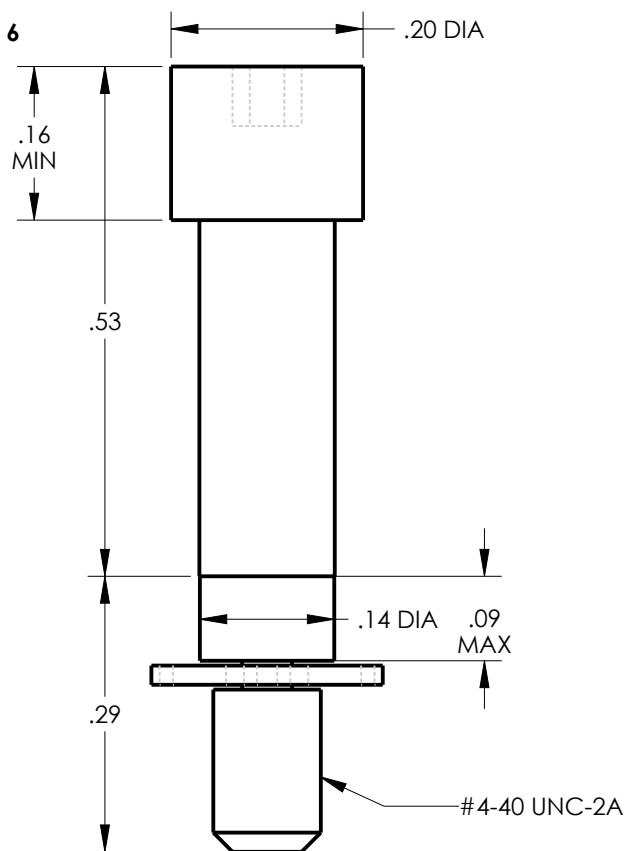

Figure 7

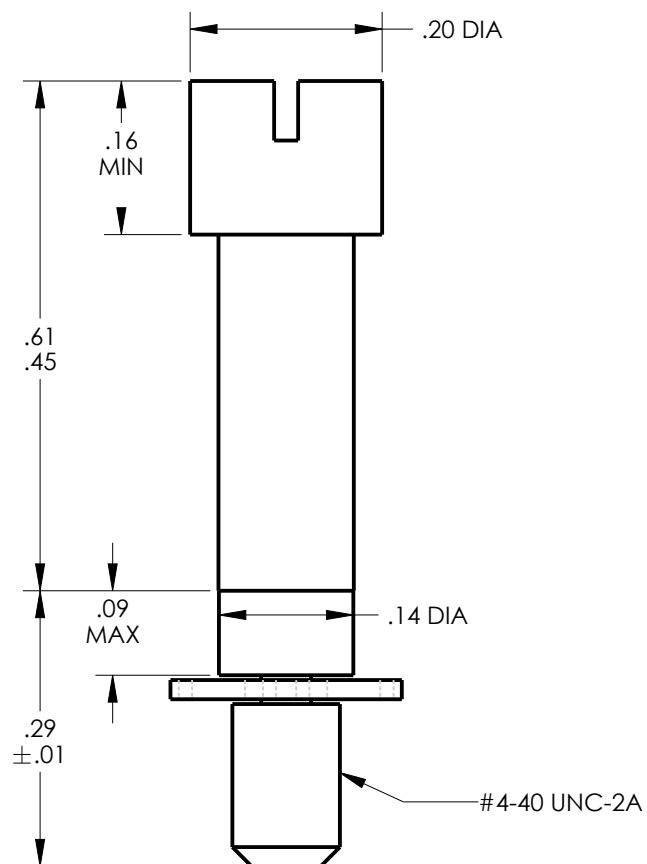

Figure 9

B

B

A

ORDER INFORMATION					
TYPE	STYLE	SCREWHEAD	THREAD	DURACON PART NO.	Figure
JACKSCREW	LOW POST	HEX	#4/40*	DCJS100HLP	6
JACKSCREW	HIGH POST	HEX	#4/40*	DCJS100H	7
JACKSCREW	LOW POST	SLOTTED	#4/40*	DCJS100SLP	8
JACKSCREW	HIGH POST	SLOTTED	#4/40*	DCJS100S	9
JACKPOST	--	--	#4/40*	DCJP100	10

UNITS ENGLISH INCHES		CINCH		1700 FINLEY RD LOMBARD, IL. 60148	
DO NOT SCALE DRAWING		TITLE JACKPOST AND JACKSCREW SALES DRAWING			
UNLESS OTHERWISE SPECIFIED: ALL DIMENSIONS ARE IN INCHES		PRO/E DRAWING			
Fillet/Radii .02 MAX		TOLERANCES .X ± .1 .XX ± .01 .XXX ± .005 ANGULAR ± .5°		CAD FILE NUMBER DCJ HARDWARE	
THIS DOCUMENT IS THE PROPERTY OF CINCH. NEITHER THIS DOCUMENT NOR ANY OF THE INFORMATION CONTAINED IN IT MAY BE DUPLICATED OR DISCLOSED WITHOUT PRIOR WRITTEN CONSENT OF CINCH.		DRAWING NUMBER DCJ HARDWARE		REV A	
CAGE IDENT NO. 71785		SIZE B		SCALE 5:1	
				SHEET 2 OF 2	

8

7

6

5

4

3

2

1