

2.92mm Plug, Solder Clamp for Semflex HP160 Cable

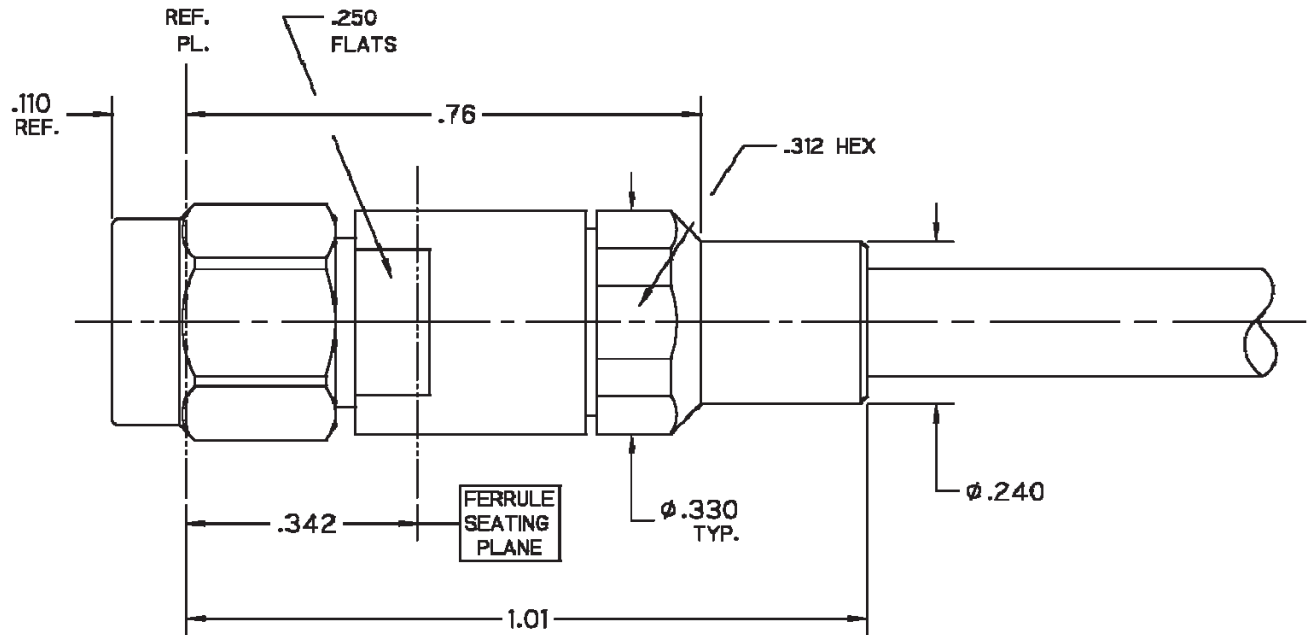

NOTES:

1.0 Materials

- 1.1 Body, Coupling, and Clamp Nuts: Steel. Corrosion Resistant per ASTM-A582. UNS No. S30300.
- 1.2 Center Conductor: Beryllium Copper per ASTM-B196. UNS C17300.
- 1.3 Solder Ferrule: Brass per ASTM-B16. UNS C36000.
- 1.4 Lock Ring: Beryllium Copper per ASTM-B197. UNS C17200.
- 1.5 Gasket and O-Ring: Silicone Rubber per A-A-59588.
- 1.6 Dielectric Bead: Polyphenylene Oxide (NORYL) per ASTM-D4349.
- 1.7 Cable Stop: Polyetherimide Thermoplastic (ULTEM 1000) per ASTM-D5205.

2.0 Finishes

- 2.1 Center Contact and Solder Ferrule: Gold Plate per ASTM-B488 50 Microinches Min. thickness over Electrolytic Nickel Plate per ASTM-B689 50 Microinches Min. thickness.
- 2.2 Body, Coupling, and Clamp Nuts: Passivated per SAE-AMS-2700.
- 2.3 Gasket, O-Ring, Lock Ring, and Dielectrics: None.

3.0 Interface: per CC-2.92mm-Pin.



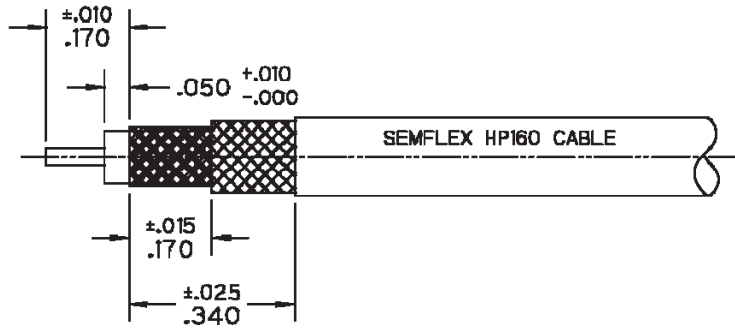

Step 1 1.1 Trim Cable as shown.

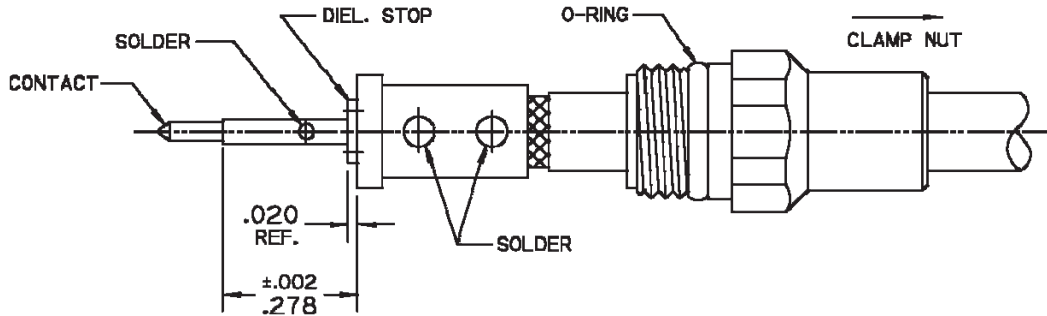

- 2.1 Install O-ring onto clamp nut where shown and slide clamp nut over cable in orientation shown.
- 2.2 Insert cable into solder ferrule until dielectric and foil are flush with solder ferrule face and solder cable braids where shown.
- 2.3 Slide dielectric stop over cable center conductor and solder contact flush to stop to dimension shown.

Step 2

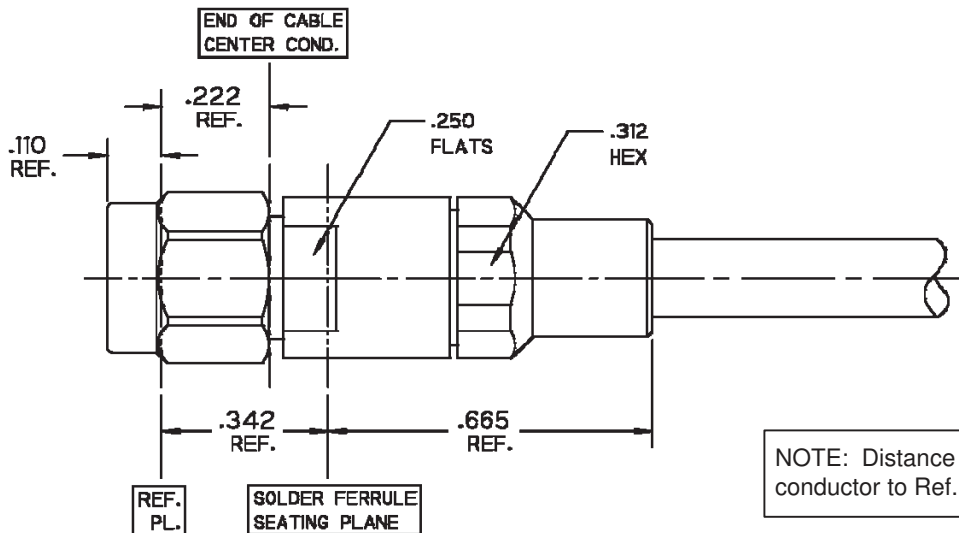

3.1 Insert cable/contact sub-assembly into connector until seated and tighten clamp nut to 25-35 in-lbs.

Step 3

Product Control:			
Crystek Part Number:	CS-FM-MSB	Release Date:	04-Jan-11
Revision Level:	A	Responsible:	K. Piotrowicz