

## 2-channel interleaved PFC driver with embedded digital inrush current limiter function



### Features

- Embedded digital inrush current limiter function
- Interleaved PFC digital controller
- Two interleaved channels PFC
- Continuous conduction mode
- Fixed frequency operation
- Average current mode control
- Mixed signal architecture
- Soft start-up management
- Burst mode support
- Load feed forward
- Input voltage feed forward
- Channel current balance function
- Programmable phase shedding
- Status indicator signaling for cooling system, PFC Fault and PFC OK
- Configurable driver by means of dedicated graphic tool
- Programmable fast overcurrent and thermal protection
- Serial communication port available for:
  - Device programming;
  - Monitoring of the PFC parameters
- Suitable for >600 W applications:
  - Welding, air conditioner
  - Industrial motors
  - UPS, chargers, high power systems
- Customizable firmware
- Configuration via eDesign suite
- Embedded memory
  - Program memory: 32 Kbytes flash
  - Data retention 15 years at 85 °C after 10 kcycles at 25 °C
  - Data memory: 1 Kbyte true data E<sup>2</sup>PROM; data retention: 15 years at 85 °C after 100 kcycles at 85 °C
  - Flash and E<sup>2</sup>PROM with read while write (RWW) and error correction code (ECC)
  - RAM: 6 Kbytes
- Communication interfaces
  - UART asynchronous protocol for bootloader support and monitoring of the PFC parameters
- Operating temperature: -40 °C up to 105 °C

#### Product status link

[STNRGPF02](#)

[STNRGPF12](#)

#### Product summary

Package	Part number
TSSOP38	STNRGPF02
TSSOP38	STNRGPF12

#### Product label



STNRGPF02 embeds inrush current control function setting high a signal that is used to short a resistive element.

### Documentation

This datasheet contains the description of features, pinout, pin assignment, electrical characteristics, mechanical data and ordering information.

- For information on programming, erasing and protection of the internal Flash memory, please refer to the RM0446 User Manual (see [www.st.com](http://www.st.com))

## 1 General description

The STNRGPFx2 are digital controllers designed specifically for interleaved CCM boost PFC topologies in high power applications and embed the Inrush current limiter function.

The Interleaving technique splits the PFC management into two or more parallel channels depending on the load condition. The driving signal will be out of phase of a proper value.

This phase shift will be calculated basing on the number of paralleled channels according to the following formula:

### Equation 1

$$\text{Phase shift} = \frac{360^\circ}{\text{number of channels}}$$

The benefits of the interleaved topology, compared to traditional single stage PFC, are measured in terms of reduction of EMI filter and inductor volume, and a reduction of rms capacitor current.

The STNRGPFx2 contain all the control functions for designing a high efficiency-mode power supply with sinusoidal line current consumption.

They work in CCM, fixed frequency with average current mode control, implementing a mixed signal (analog/digital) control joining the advantages of very high-end digital solution without typical limits of analog ones.

In the mixed signal approach, the inner current loop is performed in hardware realizing an analog Proportional-Integral (PI) compensator, and the outer voltage loop is performed by a digital PI controller with fast dynamic response.

The STNRGPFx2 can be configured by a dedicated software tool (eDesignSuite) in order to be customized for a specific application. So, the user has to open the software tool, enters the converter specs and runs the configurator. The results will be: Schematic, BoM, and Binary code containing the parameters calculated by the tool.

The binary code can be downloaded into the STNRGPFx2 through the programming software STSW-STNRGPF01 (by means serial interface) having a customized device that can be used like analog device ready to use in application.

### 1.1 Inrush current limiter function description

The STNRGPFx2 devices have the Inrush Current Limiter function embedded. As soon as power supplies are connected to AC line, they are subject to short-duration, high amplitude, input current called "Inrush Current". The inrush current continues until the voltage across the internal capacitors reaches approximately the peak amplitude of the input AC line. If uncontrolled, the inrush current can damage the components of the power supply. Several solutions can be adopted to limit this current and STNRGPFx2 devices are able to manage two control methods.

#### 1.1.1 Inrush current limiter function with resistive element (STNRGPF02 only)

One method to limit the Inrush Current is to add a resistive element R (resistors, thermistors, etc.) in series with DC capacitors. Figure 1 shows one implementation of this technique. As soon as the capacitor C is charged, no current flows, and the STNRGPF02 will do the ON signal to switch S1 in order to short R. In this way the losses during normal operation are minimized.

Figure 1. STNRGPF02: Inrush current limiter with resistor in series to output capacitor

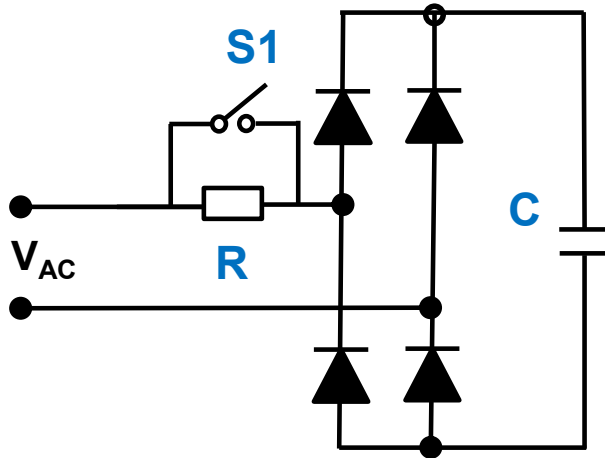

The switch  $S1$  can be a silicon device as Triac or a mechanical switch of a relay.

### 1.1.2 Inrush current limiter function with controlled bridge (STNRGPF12 only)

The second method to control the charge current of output capacitor is to replace the input bridge rectifier with a controlled one, The STNRGPF12 modulates progressively the conduction time of the switches  $S1$  and  $S2$  in order to charge smoothly the output capacitor avoiding overcurrent's in the systems. One implementation of this method circuit may use Silicon Controlled Rectifier (SCR) and the circuit in figure 2 is shown. The high side of input rectifier bridge it's composed by SCR's  $S1$ ,  $S2$  and the low side are diodes

Figure 2. STNRFPF12: Inrush current limiter with controlled rectifier bridge

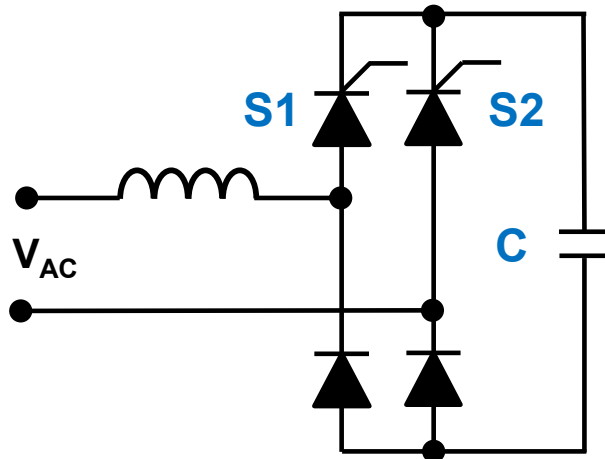

This methodology can be applied only when an inductor is present on the line. In this case an inductor is already present because the application is an Interleaved PFC.

## 2 STNRGPF02/12 control architecture

The STNRGPFx2 digital controllers implement a mixed signal (analog/digital) control. The inner current loop is performed in hardware and the outer voltage loop is performed by a digital PI controller. The device performs a cascaded control for voltage and current loops to regulate the output voltage by acting on the total average inductor current.

Figure 3. STNRGPF12 control scheme

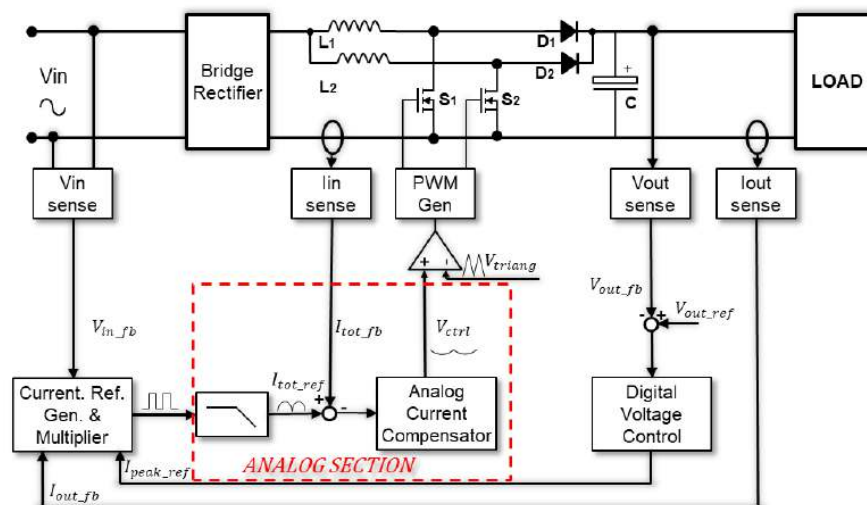

Figure 3 shows the control scheme for STNRGPFx2 controllers. As can be seen the difference between output voltage feedback  $v_{out\_fb}$  and reference  $v_{out\_ref}$  is sent to Digital Voltage Control block (PI regulator) which calculate the peak of input average total current  $ipk\_ref$ .

The PFC current reference is internally generated and come out from Multiplier block as PWM signal. After filtering it became the total average sinusoidal input current reference  $i_{tot\_ref}$  for inner current loop (analog section, red line). The difference between the current reference  $i_{tot\_ref}$  and the input current feedback  $i_{tot\_fb}$  is sent to Analog Current compensator PI.

So the master PWM signal is generated by comparing the analog PI output  $V_{ctrl}$  and a triangular wave  $V_{triang}$  at switching frequency. Finally, an interleaving operation is performed and two PWM signals  $180^\circ$  phase shifted drive S1 and S2 power switches.

Moreover, the digital section includes an input voltage and load feedforward for fast transient response when main voltage changes suddenly or a load step current occurs, avoiding large over or under-voltage on output capacitor C.

### 3 STNRGPF02/12 blocks diagram

The block diagram of both STNRGPF02/12 devices is shown in Figure 4

Figure 4. STNRGPFx2 Block diagram

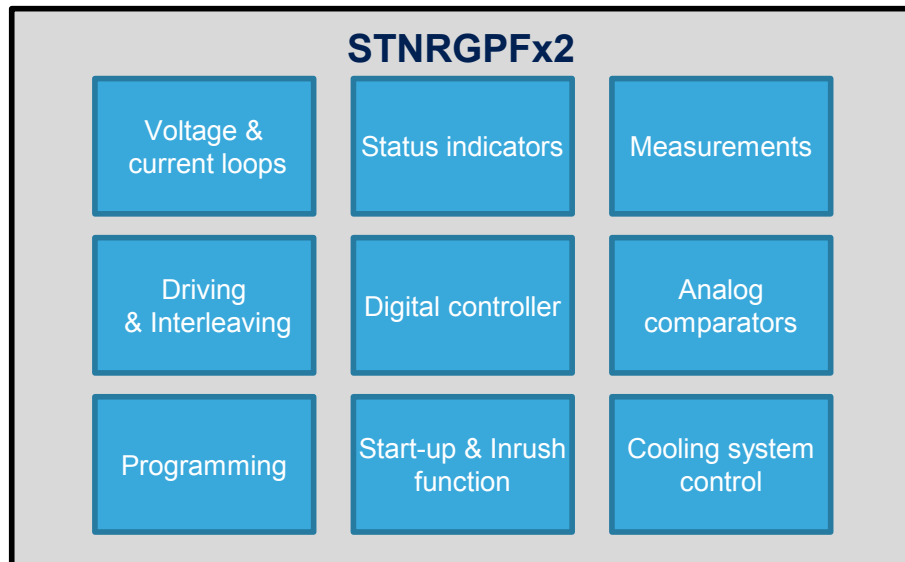

#### 3.1 Voltage and current loops

The STNRGPFx2 controllers implement a mixed signal average current control. The task of digital voltage loop is to regulate the output voltage of the PFC.  $V_{in}$  and  $I_{out}$  measurements are used to implement Input/Output Feed-Forward (I/O FFD), so load steps or input voltage variations are quickly compensated by acting on digital PI output calculations. This function allows to keep the output voltage to the setpoint value and as constant as possible (see Figure 5).

Figure 5. Voltage loop and current reference

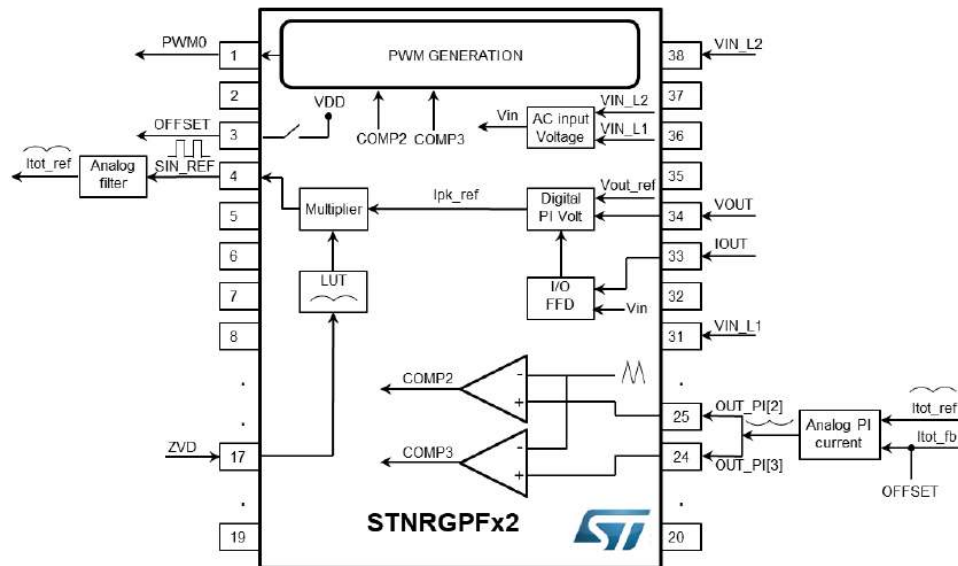

The output of digital PI is the peak current reference. In order to obtain a sinusoidal current reference  $I_{pk\_ref}$  is multiplied by a Look-Up Table (LUT). The LUT is synchronized with the Input voltage thanks to the ZVD signal (pin 17). The output of multiplier is a PWM signal having sinusoidal Duty Cycle that is configured on Pin 4 SIN REF.

An Analog filter is used to obtain the final sinusoidal current reference for the external current loop ( $I_{tot\_ref}$ ). The analog current PI compare the reference  $I_{tot\_ref}$  with the total input current feedback ( $I_{tot\_fb}$ ) and generate the duty cycle wave for PWM modulation. The master PWM signal is obtained by comparing (COMP2,3) the output of current PI (pin 24, pin 25) with a triangular wave (pin 26) at switching frequency (see Section 3.3 Analog comparators section and Section 3.4 PWM Section: driving & interleaving).

## 3.2 Measurements section

The STNRGPFx2 include 4 input measurements channels. These inputs are defined from Pin 31 to Pin 38 and they are below specified.

- Pin 31. Vin\_L1: AC Input Voltage measurement Line 1
- Pin 32. Temp: ambient temperature.
- Pin 33. Iout: PFC output current.
- Pin 34. Vout: PFC output voltage.
- Pin 35. I[0]: RMS current channel [0]
- Pin 36. I[1]: RMS current channel [1]
- Pin 38 AVin\_L2: AC Input Voltage measurement Line 2

### 3.2.1 AC input voltage measurement

The STNRGPFx2 have two dedicated pin's, Pin 31 and Pin 38, for AC RMS line voltage measurement. The devices, by means two resistor dividers, measures simultaneously the instantaneous voltage on both pins, performs the difference between them and calculate the rms value (see Figure 1  $V_{in\_fb}$  signal).  $V_{in\_fb}$  (RMS AC input voltage) is used for the following functions:

- Normal operation. It's used to generate the sinusoidal current reference signal.
- AC input voltage variation. This signal is used to implements the Input Voltage Feed Forward that modifies the voltage PI output compensating rapidly the effect of the line voltage changes. See Figure 6

Figure 6. Vin, Measurement

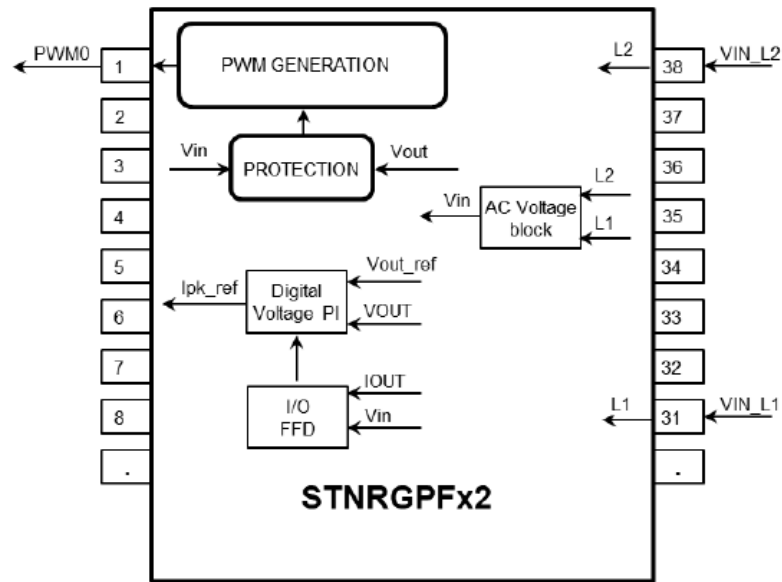

### 3.2.2 Ambient temperature measurements

Pin 32, Temp. Input for board temperature measurement. The PWM activity will be stopped when the temperature exceeds the user defined threshold. See Figure 7 . If the voltage on Temp pin, falls below a defined threshold the device will stop the system.

Figure 7. Temperature measurement

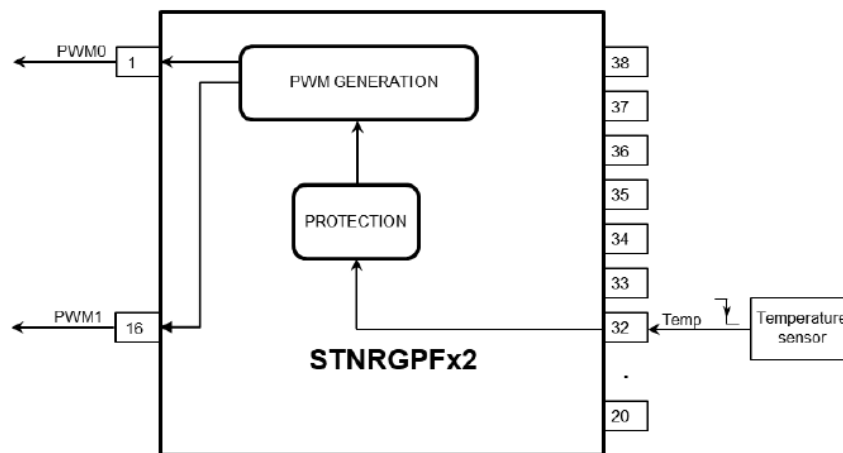

The admissible voltage that the pin can accept is between 0 and 1.23 V



### 3.2.3 Output Current measurement

Pin 33, IOUT. PFC Output current. The measurement of this current allows to implement the following functions.

- Load feedforward. The input current reference is modified proportionally to the load, in order to give a faster response versus load transient.
- Channels power management. Each channel can be enabled or disabled based on output current level. For example, up to 50% of the load, only one channel may be enabled, above 50% two channel configurations can be selected,

### 3.2.4 Output voltage sensing

Pin 34, VOUT. Output Voltage sensing. This feedback input is connected via a voltage divider to the boost output voltage. The voltage divider will give the Vout\_fb to Digital Voltage Control Block and it's used in order to implements the following functions.

- Output voltage regulation.
- Over voltage protection

In Figure 8 the block scheme of Vin IOUT and VOUT is reported.

Figure 8. Vin, IOUT and VOUT Measurement

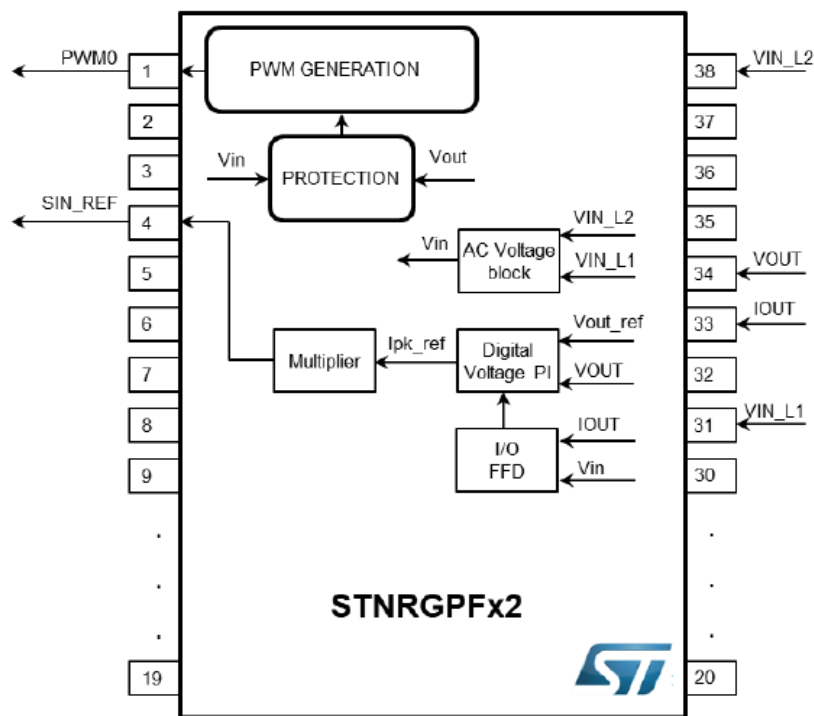

### 3.2.5 Channel current measurement

Pin 35 Pin 36. ICH[0], ICH[1]: channel current measurements. These pins measure the currents flowing in each channel. The signal coming from sensing resistors is sent to a low pass filter and finally it's connected to Pin 35 and Pin 36. The low pass filter must be sized so that its passband is about ten times lower than the switching frequency of the single channel. The result of this measurement is internally used to perform the current balance between the two channels.

Figure 9. Channel current measurement

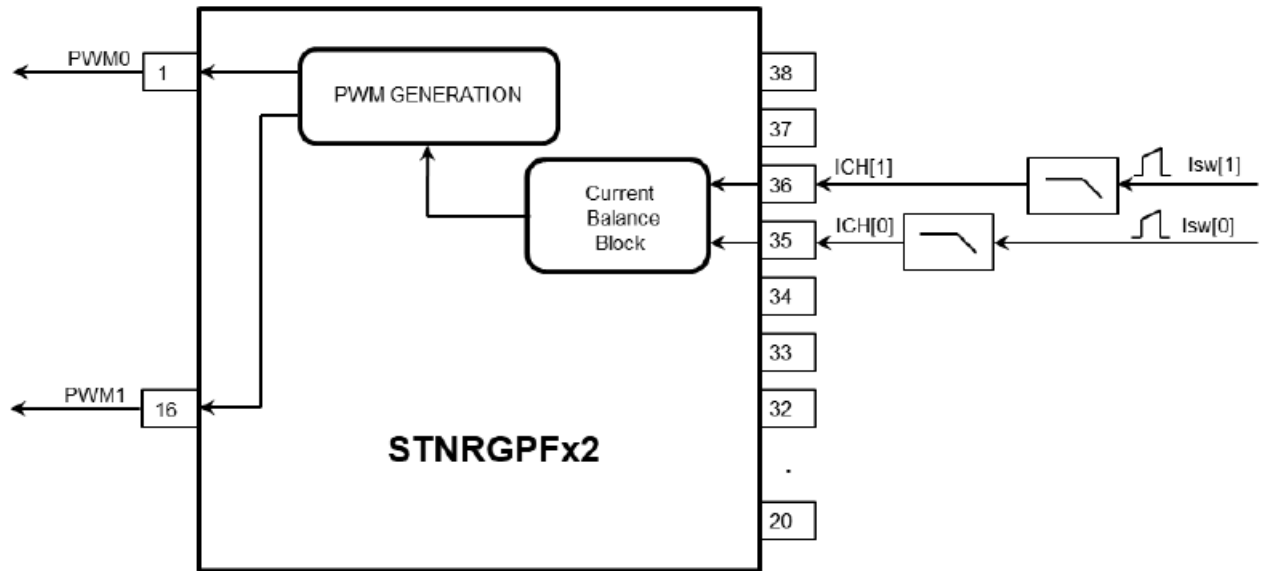

### 3.3 Analog comparators section

The STNRGPFx2 include four fast analog comparators, COMP0 ... 3.

COMP3 and COMP2 have external reference voltage and they are used to define the duty cycle of PWM0 master.

COMP1 and COMP0 have internal reference voltage and are used to realize overcurrent protections.

**Figure 10. Analog comparators section**

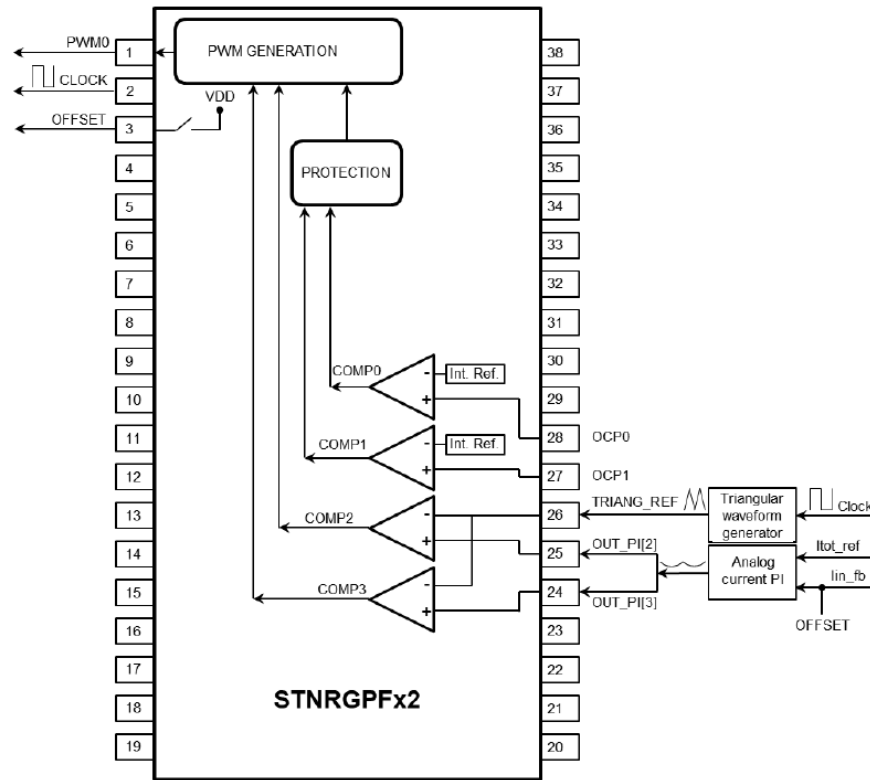

A description of the comparator pins is reported below.

- Pin 24 OUT\_PI[3]: Positive input of COMP3. It receives the out of analog PI current.
- Pin 25 OUT\_PI[2]: Positive input of COMP2. It receives the out of analog PI current.
- Pin 26 TRIANG\_REF: Negative common input analog COMP2,3. It receives the reference triangular waveform.
- Pin 27: Positive input of COMP1. It receives the sensing signal of total input current.
- Pin 28: Positive input of COMP0. It receives the sensing signal of all switch currents.

COMP0 stops the driving when an overcurrent occurs in any switch.

### 3.4 PWM Section: driving & interleaving

The STNRGPFx2 PWMs for channels driving are pins: 1 and 16. Below [Figure 11](#) shows the configuration for PWMs generation.

Figure 11. Driving & interleaving

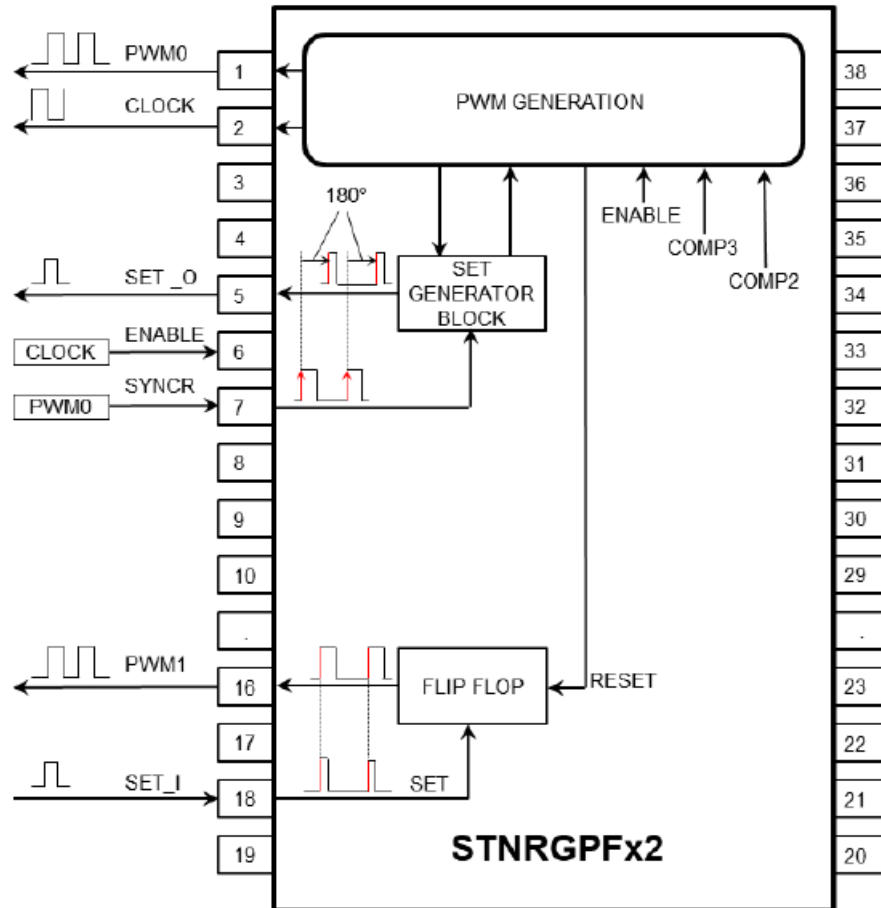

Once the device is programmed as soon as the device is supplied the following sequence to generate the PWM starts:

- Pin n. 2 emits CLOCK signal at selected switching frequency. This pin must be connected to ENABLE pin (n. 6) and the clock signal will be internally used in order to enable the PWM GENERATION block. The ENABLE signal moreover is used to avoid undesired commutations also when high level of noise is present.
- The PWM0 signal trigger the SYNCR pin (pin 7) and internally the SET GENERATOR BLOCK will generate the SET pulse with an out of phase of 180° (for a correct interleaving) respect the PWM0 signal. The SET will fix the “ON” instant of PWM1 signal.
- The SET signal comes out from the SET\_O pin and will enter in the SET inputs (pin 18 SET\_I) of an internal FLIP FLOP.

The internal FLIP FLOP receives the SET from pin 18 and the RESET signal from PWM GENERATION BLOCK and in this way it is able to generate the PW1 with the right out of phase respect to PWM0. The PWM1 comes out from the pin 16 “PWM1”.

### 3.5 Programming section

Device programming is done by using: a PC with a dedicated loader software (STSW-STNRGPF01), a FTDI cable and an adapter board (See Figure 12.)

Figure 12. Programming section

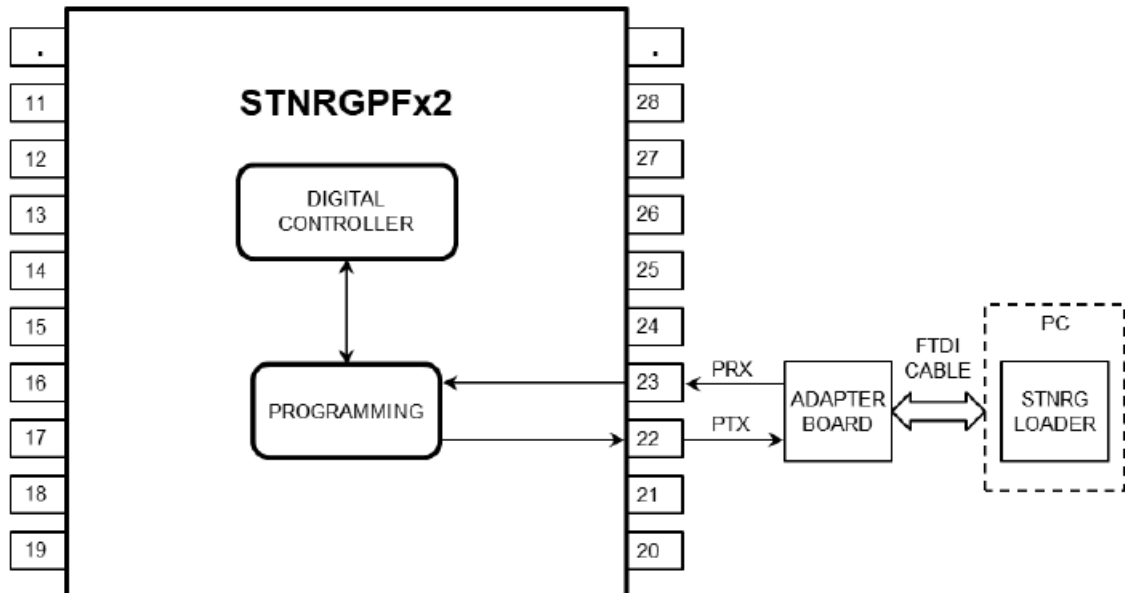

### 3.6 Status indicator

The STNRGPFx2 include two pin to identify the running or fault status. These functions are defined on Pin 14 and Pin 15 (See Figure 13 )

Figure 13. Status Indicator

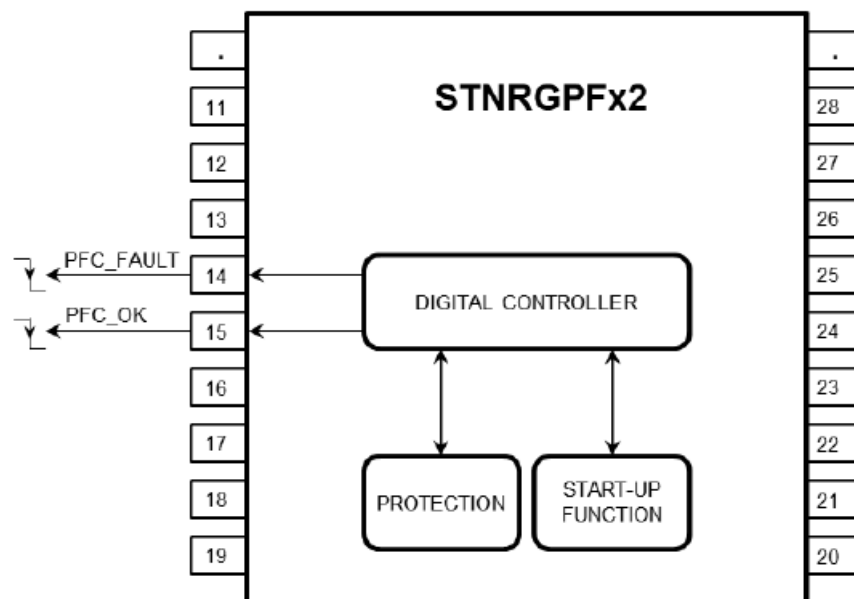

### 3.7 Start-up & Inrush Current Limiter function

The start-up function can be divided in two phases. The first phase is the Inrush Current Limiter and the second phase is the PFC Soft Power-On.

In Figure 14 the timing of start-up sequence is reported.

Figure 14. Start-Up sequence

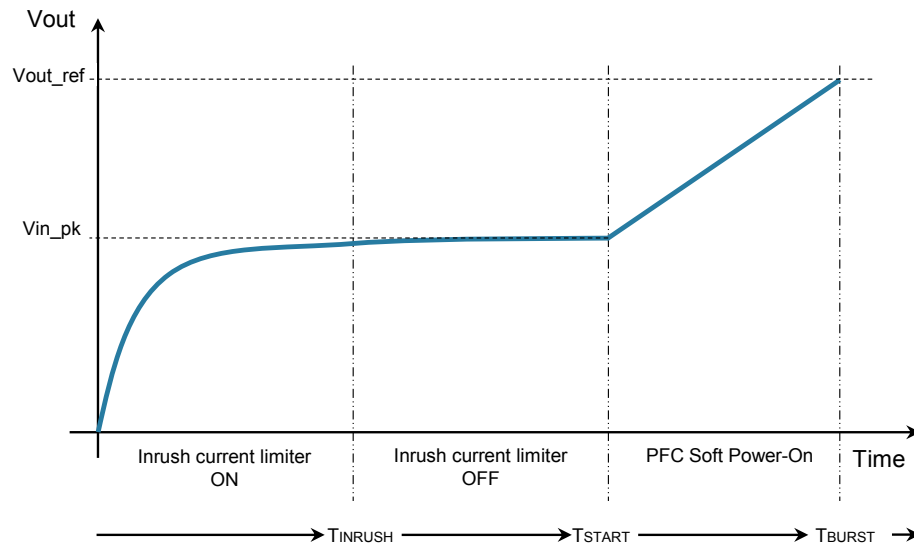

Initially the device performs the function of “Inrush Current Limiter” and after the  $T_{nrush}$  time it stops this phase. Sequentially it applies a short delay and at the end starts the PFC Soft Power-On procedure increasing the  $V_{out}$  voltage up to the nominal voltage ( $V_{out\_ref}$ ).

### 3.7.1 Inrush Current Limiter Function

The devices embed the Inrush Current Limiter Function. There are several topologies to perform this function but the most used are the following:

1. Inrush Current Limiter function with limiter resistor and bypass relay. This solution consists to insert a resistor in series with the output capacitors. The capacitor Inrush current is limited by a resistor or a thermistor. As soon as the capacitor is charged in STNRGPF02 set high pin 21 and this signal is used to short resistor using the Switch S1 (See Figure 15) in order to reduce the power losses. This switch S1 can be a silicon-based switch or mechanical contact of a relay.

Figure 15. Inrush Current Limiter function with limiter resistor and bypass relay

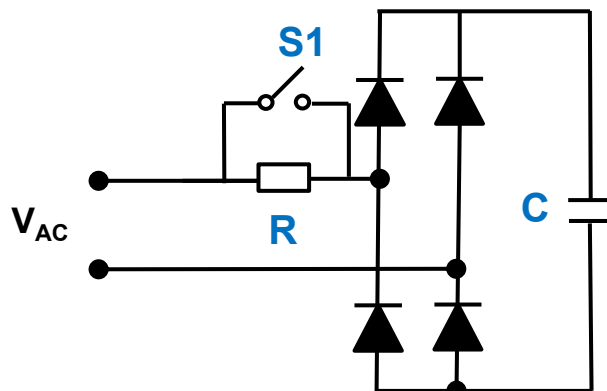

2. Digital Inrush Current Limiter function with a semi-controlled input bridge: Another topology uses a semi-controlled bridge composed by two silicon switches T1, T2 (SCR, IGBT....) and two separate diodes for the inrush path. T1, T2 are modulated ON and OFF by the controller in order to limit the peak current but this can work if an inductor is present in series with the line. (see Figure 16)

Figure 16. Digital Inrush Current Limiter function with a semi-controlled input bridge

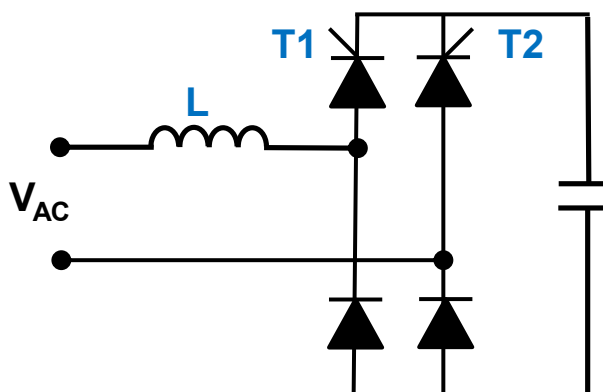

STNRGPF12 has embedded this technique, and it drives T1 and T2 alternately according to the polarity of the mains and applying a short ON time. To reduce the inrush current the switches are triggered at the end of the line voltage. In this way the output capacitors initially are charged at low voltage and after it will increase smoothly allowing also a better control of the Inrush current.

Figure 17. Digital Inrush Current Limiter function: sequence of driving of the SCR

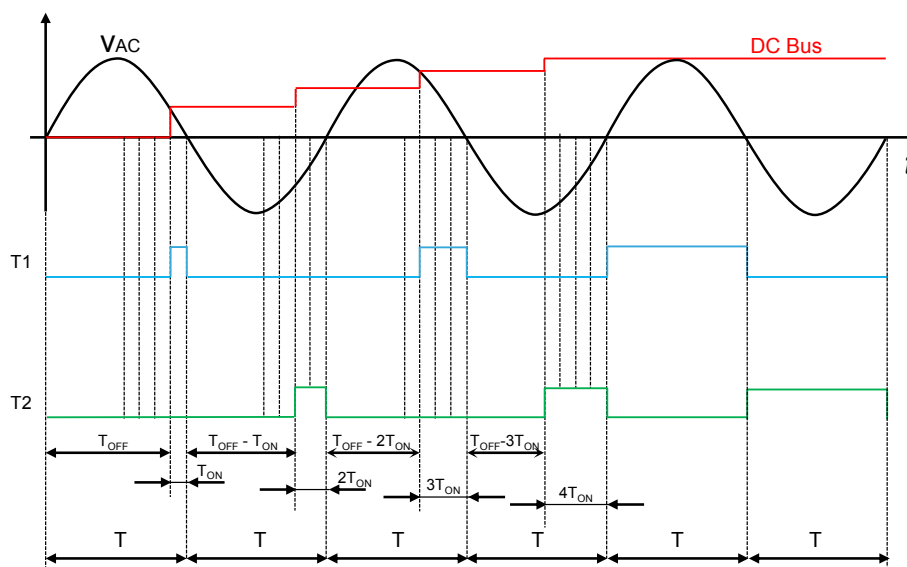

In order to charge the output capacitors up to the peak voltage of AC mains, the switches T1 and T2 must be triggered on the following cycle with  $T_{ON}$  phase shift respect the previous one. (See Figure 17). If this Step Phase Shift is very short (few microseconds) from half cycle to half cycle, thanks to the presence of the PFC inductors, the capacitors will be charged maintaining low the line current. Usually this delay is constant, and we call this technique “Constant Progressive Step Phase Control”.

### 3.7.2 PFC Soft Power-ON

After the inrush current limiter phase the device will perform the Soft Power-On phase. The current reference will generate a constant reference signal and both PWM0 and PWM1 channels will be activated. In this phase the PFC output voltage will increase up to the setpoint ( $V_{out\_ref}$ ).

As soon as the PFC Soft Power ON procedure is completed and the voltage reaches the setpoint  $V_{out\_ref}$  (See Figure 18) the device performs the following operations:

- **The PFC\_OK pin is pulled low.** When this pin is low indicates that the PFC is ready for load connection on the output.

- **The device will enter in Burst Mode regulation.** The PFC output voltage will oscillate between two settable levels ( $V_{burst\_min}$  and  $V_{burst\_max}$ ). These levels can be defined during device customization.

Figure 18. Running mode or Burst mode

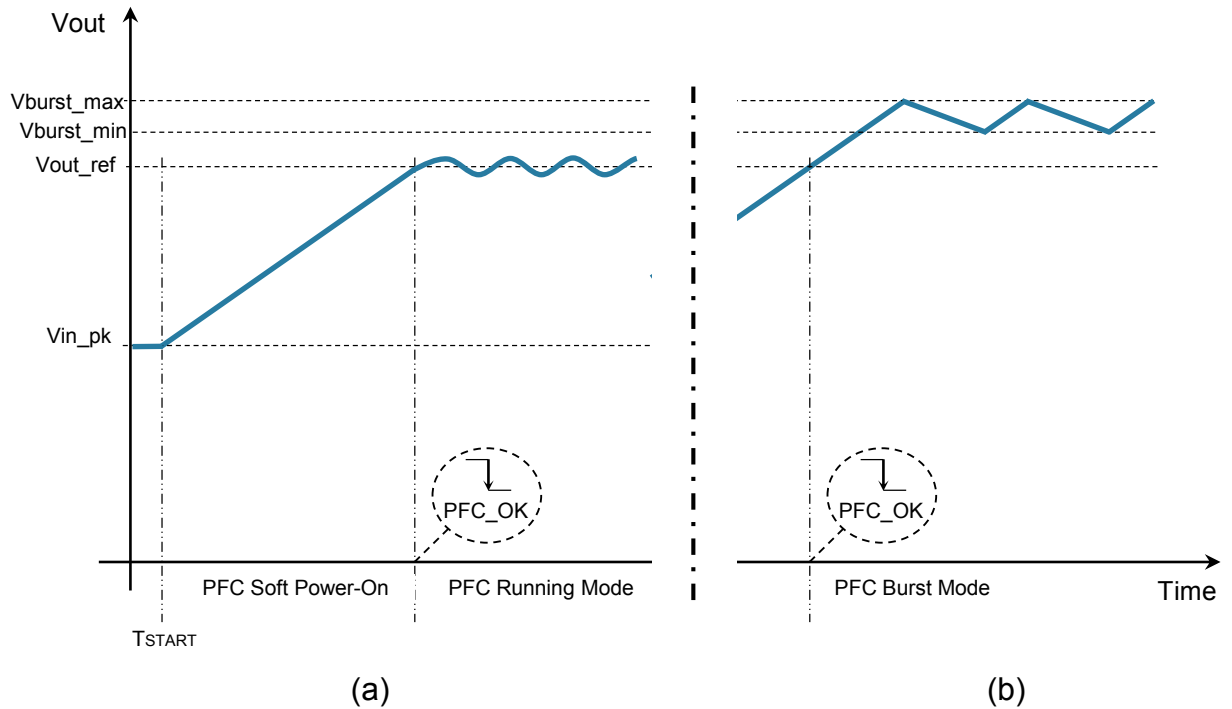

As soon as the PFC\_OK pin becomes low two conditions may occur: The load is applied.

- The device immediately will regulate the output voltage at  $V_{out\_ref}$  value. [Figure 18 \(a\)](#)
- The PFC remains in no-load condition: the output voltage will range between  $V_{burst\_min}$  and  $V_{burst\_max}$  until the load will be applied [Figure 18 \(b\)](#)

### 3.7.3 Fan control

The device offers the possibility to realize a control on cooling system. The customer will defines the power level for the function activation. Pin 20 , FAN gives a CMOS/TTL signal that became low for power level higher than the specified threshold. See [Figure 19](#).



Figure 19. Fan Control function

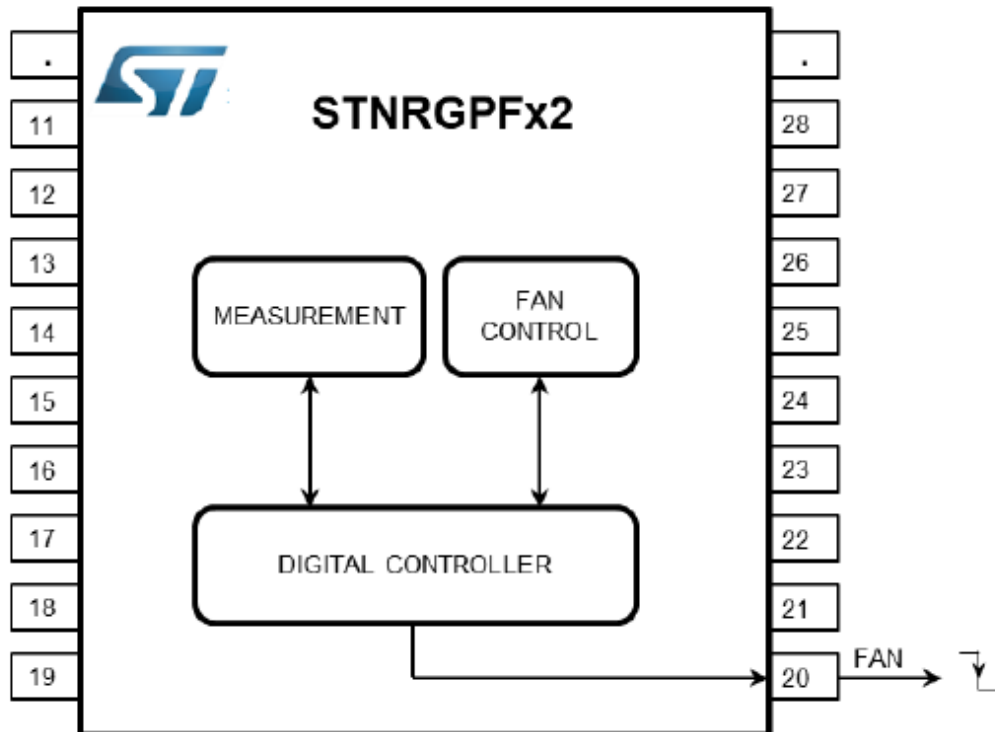

## 4 Pinout and pin description

### 4.1 Pinout

Figure 20. STNRGPF12 - TSSOP38 pinout

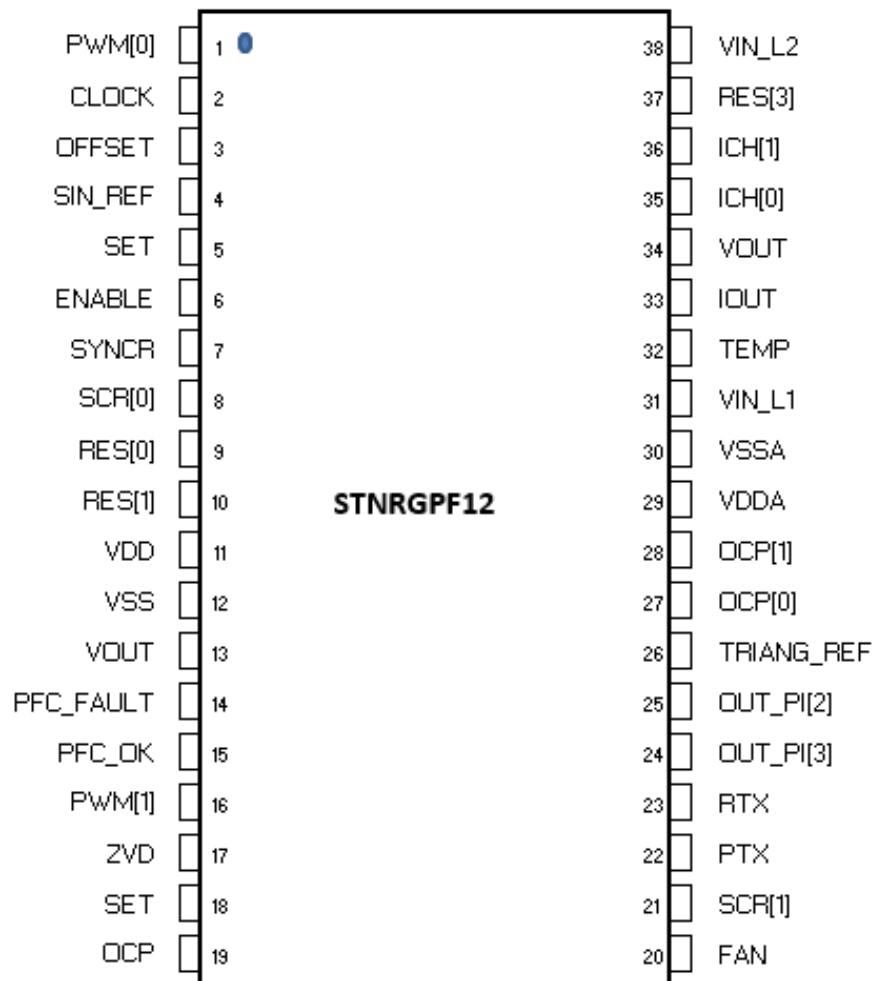

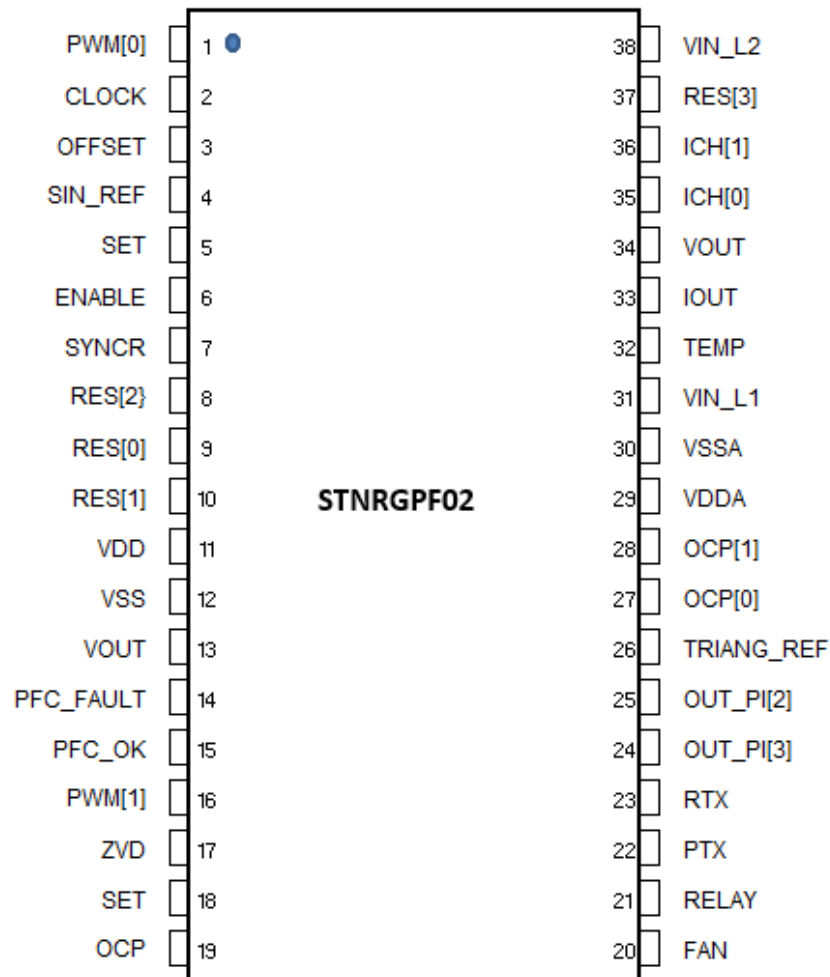
**Figure 21. STNRGPF02 - TSSOP38 pinout**

## 4.2 Pin description

**Table 1. Pin description**

N	TYPE <sup>(1)</sup>	NAME STNRGPF12	NAME STNRGPF02	PIN DESCRIPTION
1	OP	PWM[0]	PWM[0]	This pin generates the PWM0 for the channel CH[0]
2	O	CLOCK		This pin generates a PWM signal at selected working frequency having duty cycle 50%. This signal it's used to generate a triangular waveforms at switching frequency by means an external op_amp. The CLOCK signal is also used to realize a protection against undesired commutations
3	O	OFFSET		This pin generated a PWM signal in order to compensate the offset of the external operational amplifier that performs the current loop PI compensator.

N	TYPE <sup>(1)</sup>	NAME STNRGPF12	NAME STNRGPF02	PIN DESCRIPTION
4	OP	SIN_REF		This pin generates a PWM signal with sinusoidal duty cycle. This PWM signal must be filtered in order to have the current sinusoidal reference that is synchronized with input voltage mains.
5	OP	SET_O		This pin generates a pulse in order to trigger set ON the CH1 channel with the right out of phase. This pin must be connected to pin 18
6	I	ENABLE		This pin receive the CLOCK signal in order to avoid undesired commutation
7	I	SYNCR[2]		This pin receives the PWM0 signal in order to synchronize the others channels. The falling edge of PWM0 signal is used to trigger OFF the slave channels CH1 and CH2
8	OP	SCR[0]	RES[2]	<b>STNRGPF12:</b> This pin generates the PWM signal in order to drive one of the two switches in the input semicontrolled bridge to performs the Inrush Current Limiter feature. The switch can be an SCR. <b>STNRGPF02:</b> Reserved
9	NC	RES[0]		Reserved
10	NC	RES[1]		Reserved
11	PS	V <sub>DD</sub>		Supply Voltage
12	PS	V <sub>SS</sub>		Ground
13	PS	V <sub>OUT</sub>		Supply Voltage of digital section. An external capacitor must be connected to VOUT pin.
14	O	P <sub>FC_FAULT</sub>		During normal operation this pin is high. If a fault condition happens it's forced low.
15	O	P <sub>FC_OK</sub>		During fault condition this pin is high. When the PFC is ready for load connection it's forced low.
16	OP	PWM[1]		This pin generates the PWM for the channel CH1
17	I	ZVD		This pin receives a square wave signal synchronized with input AC voltage. The rising edge of square wave signal is used by the STNRGPF12 to detect the ZVD instant.
18	I	SET_I		This pin receives a pulse in order to trigger ON the CH1 channel. This pin must be connected to pin 5
19	O	OCP		During normal operation this pin is high. If an overcurrent occurs, it's forced low instantaneously
20	O	FAN		It generates a CMOS/TTL signal that is low until the PFC output power is below a threshold defined during device customization
21	OP	SCR[1]	RELAY	<b>STNRGPF12:</b> This pin generates the PWM signal in order to drive one of the two switches in the input semicontrolled bridge to performs the Inrush Current Limiter feature. The switch can be an SCR. <b>STNRGPF02:</b> It generates a signal that is low during the inrush phase. As soon as the inrush phase is completed this signal became high and it can be used to short the limiter resistor or to disable any current limiter apparatus
22	O	PTX		Programming data transmit
23	I	PRX		Programming data receive
24	AI	OUT_PI[3]		Positive input of internal analog comparator 3. It receives the out of analog PI current
25	AI	OUT_PI[2]		Positive input of internal analog comparator 3. It receives the out of analog PI current

N	TYPE <sup>(1)</sup>	NAME STNRGPF12	NAME STNRGPF02	PIN DESCRIPTION
26	AI	TRIANG REF		Negative input analog comparators 3 and 2. It receives voltage triangular waveform
27	AI	OCP[0]		Input overcurrent protection
28	AI	OCP[1]		Inductor overcurrent protection
29	PS	V <sub>DDA</sub>		Analog supply voltage
30	PS	V <sub>SSA</sub>		Analog ground
31	MI	V <sub>IN_L1</sub>		This pin is one of the two inputs for the RMS input voltage measurements. A divider resistor is connected to line/neutral input wire
32	MI	TEMP		This pin is used to performs a double function : 1) monitoring the ambient board temperature. This measurement is realized using the curve of STLM20 device that give an output voltage proportional to temperature. 2) overtemperature protection: if the voltage falls below a settable treshold the device enter in fault mode and will stop the PFC.
33	MI	I <sub>OUT</sub>		This pin measures the PFC output current
34	MI	V <sub>OUT</sub>		This pin measures the PFC output voltage
35	MI	ICH[0]		This pin measure the rms current for channel CH[0]
36	MI	ICH[0]		This pin measure the rms current for channel CH[1]
37	RI	ICH[2]	RES[3]	Reserved. This pin must be pulled down by means a 10k resistor
38	MI	V <sub>IN-L2</sub>		This pin is one of the two inputs for the RMS input voltage measurements. A divider resistor is connected to line/neutral input wire

1. In the following table the legend of pin type is shown.

**Table 2. Legend of the pins**

TYPE	Pin identification
OP	PWM driver
O	Digital output
I	Digital input
I/O	Digital bidirectional
PS	Power supply
AI	Analog input
MI	Measure input

### 4.3 Input/output specification

The STNRGPFx2 family includes three different I/O types:

- Normal I/Os (O or I);
- Fast I/O (OP);
- High speed I/O (CLOCK)

The STNRGPFx2 I/Os are designed to withstand current injection. For a negative injection current of 4 mA, the resulting leakage current in the adjacent input does not exceed 1  $\mu$ A.

## 5 Electrical characteristics

### 5.1 Parameter conditions

Unless otherwise specified, all voltages are referred to  $V_{SS}$ .  $V_{DDA}$  and  $V_{DD}$  must be connected to the same voltage value.  $V_{SS}$  and  $V_{SSA}$  must be connected together with the shortest wire loop.

#### 5.1.1 Minimum and maximum values

Unless otherwise specified, the minimum and maximum values are guaranteed in the worst conditions of ambient temperature, supply voltage and frequencies by tests in production on 100% of the devices with the ambient temperature at  $T_A = 25\text{ °C}$  and  $T_A = T_A \text{ max.}$  (given by the selected temperature range).

Data based on characterization results, design simulation and/or technology characteristics are indicated according to each table's specific notes and are not tested in production.

#### 5.1.2 Typical values

Unless otherwise specified, typical data are based on  $T_A = 25\text{ °C}$ ,  $V_{DD}$  and  $V_{DDA} = 3.3\text{ V}$ . They are given only as design guidelines and are not tested. For the measurement section the accuracy is determined by characterization of a batch of samples from a standard diffusion lot over the full temperature range.

#### 5.1.3 Typical curves

Unless otherwise specified, all typical curves are given as design guidelines only and are not tested.

#### 5.1.4 Typical current consumption

For typical current consumption measurements,  $V_{DD}$  and  $V_{DDA}$  are connected as shown in Figure 22

**Figure 22. Supply current measurement conditions**

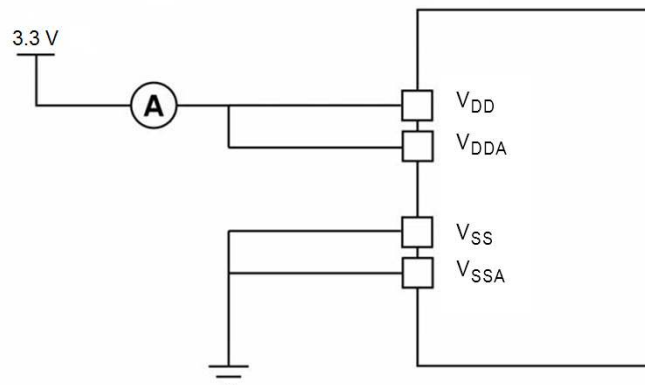

#### 5.1.5 Loading capacitors

The loading conditions used for pin parameter measurement are shown in Figure 23.

Figure 23. Pin loading conditions

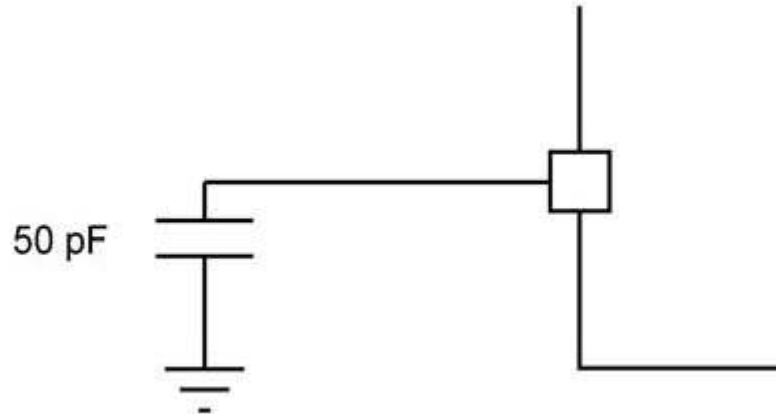

### 5.1.6 Pin output voltage

The input voltage measurement on a pin is described in Figure 24.

Figure 24. Pin input voltage

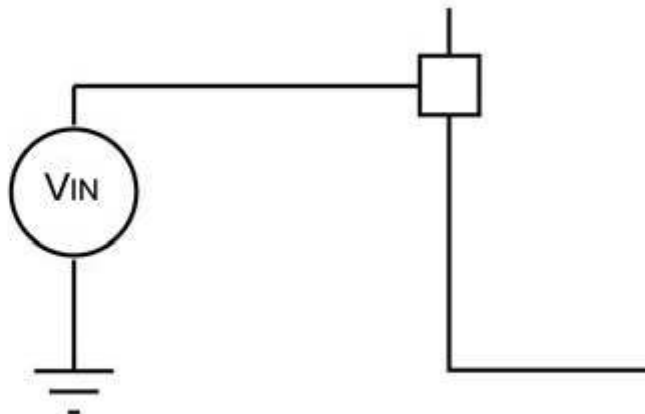

## 5.2 Absolute maximum ratings

Stresses above those listed as 'absolute maximum ratings' may cause permanent damage to the device. This is a stress rating only and the functional operation of the device under these conditions is not implied. Exposure to maximum rating conditions for extended periods may affect the device reliability.

Table 3. Voltage characteristics

Symbol	Ratings	Min.	Max.	Unit
$V_{DDX} - V_{SSX}$	Supply voltage <sup>(1)</sup>	-0.3	6.5	V
$V_{IN}$	Input voltage on any other pin <sup>(2)</sup>	$V_{SS} - 0.3$	$V_{DD} + 0.3$	

Symbol	Ratings	Min.	Max.	Unit
$V_{DD}-V_{DDA}$	Variation between different power pins		50	mV
$V_{SS}-V_{SSA}$	Variation between all the different ground pins <sup>(3)</sup>		50	

1. All power  $V_{DDX}$  ( $V_{DD}$ ,  $V_{DDA}$ ) and ground  $V_{SSX}$  ( $V_{SS}$ ,  $V_{SSA}$ ) pins must always be connected to the external power supply
2.  $I_{INJ(PIN)}$  must never be exceeded. This is implicitly insured if  $V_{IN}$  maximum is respected. If  $V_{IN}$  maximum cannot be respected, the injection current must be limited externally to the  $I_{INJ(PIN)}$  value. A positive injection is induced by  $V_{IN} > V_{DD}$  while a negative injection is induced by  $V_{IN} < V_{SS}$ .
3.  $V_{SS}$  and  $V_{SSA}$  signals must be interconnected together with a short wire loop

**Table 4. Current characteristics**

Symbol	Ratings	Max <sup>(1)</sup>	Unit
$I_{VDDX}$	Total current into $V_{DDX}$ power lines <sup>(2)</sup>	100	mA
$I_{VSSX}$	Total current out of $V_{SSX}$ power lines <sup>(2)</sup>	100	
$I_{IO}$	Output current sunk by any I/Os and control pin	Ref. to Table 11	
	Output current source by any I/Os and control pin	-	
$I_{INJ(PIN)}$ <sup>(3), (4)</sup>	Injected current on any pin	$\pm 4$	
$I_{INJ(TOT)}$ <sup>(3), (4), (5)</sup>	Sum of injected currents	$\pm 20$	

1. Data based on characterization results, not tested in production.
2. All power  $V_{DDX}$  ( $V_{DD}$ ,  $V_{DDA}$ ) and ground  $V_{SSX}$  ( $V_{SS}$ ,  $V_{SSA}$ ) pins must always be connected to the external power supply.
3.  $I_{INJ(PIN)}$  must never be exceeded. This is implicitly insured if  $V_{IN}$  maximum is respected. If  $V_{IN}$  maximum cannot be respected, the injection current must be limited externally to the  $I_{INJ(PIN)}$  value. A positive injection is induced by  $V_{IN} > V_{DD}$  while a negative injection is induced by  $V_{IN} < V_{SS}$
4. Negative injection disturbs the analog performance of the device.
5. When several inputs are submitted to a current injection, the maximum  $I_{INJ(PIN)}$  is the absolute sum of the positive and negative injected currents (instantaneous values). These results are based on characterization with the  $I_{INJ(PIN)}$  maximum current injection on four I/O port pins of the device.

**Table 5. Thermal characteristics**

Symbol	Ratings	Max.	Unit
$T_{STG}$	Storage temperature range	-65 to 150	°C
$T_J$	Maximum junction temperature	150	

## 5.3 Operating conditions

The device must be used in operating conditions that respect the parameters listed in Table 6. In addition, a full account must be taken for all physical capacitor characteristics and tolerances.

**Table 6. General operating conditions**

Symbol	Parameter	Conditions	Min.	Typ.	Max.	Unit
$V_{DD1}, V_{DDA1}$	Operating voltages	-	3	-	5.5	V
$V_{DD}, V_{DDA}$	Nominal operating voltages	-	-	5	-	
$V_{COUT}$	Core digital power supply	-	-	1.8 <sup>(1)</sup>	-	



Symbol	Parameter	Conditions	Min.	Typ.	Max.	Unit
(Continued) $V_{COUT}$	$C_{VOUT}$ : capacitance of external capacitor <sup>(2)</sup>	at 1 MHz	470	-	3300	nF
	ESR of external capacitor <sup>(1)</sup>		0.05	-	0.2	$\Omega$
	ESL of external capacitor <sup>(1)</sup>		-	-	15	nH
$\Theta_{JA}$	FR4 multilayer PCB	TSSOP38	-	80	-	$^{\circ}\text{C/W}$
$T_A$	Ambient temperature	$P_d = 100 \text{ mW}$	-40	-	105	$^{\circ}\text{C}$

1. Internal core power supply voltage.
2. To calculate  $P_{Dmax}(T_A)$ , use the formula  $P_{Dmax} = (T_{Jmax} - T_A)/\Theta_{JA}$ .
3. Care should be taken when the capacitor is selected due to its tolerance, its dependency on temperature, DC bias and frequency.

**Table 7. Operating conditions at power-up/power-down**

Symbol	Parameter	Conditions	Min. <sup>(1)</sup>	Typ.	Max. <sup>(1)</sup>	Unit
$t_{VDD}$	VDD rise time rate		2 $\mu\text{s/V}$		1 $\text{s/V}^{(1)}$	
	VDD fall time rate		2 $\mu\text{s/V}$		1 $\text{s/V}^{(1)}$	
$t_{TEMP}$	Reset release delay	VDD rising		3		ms
$V_{IT+}$	Power-on reset threshold		2.65	2.8	2.98	V
$V_{IT-}$	Brownout reset threshold		2.58	2.73	2.88	
$V_{HYS(BOR)}$	Brownout reset hysteresis			70		mV

1. Guaranteed by design, not tested in production.

### 5.3.1 VOUT external capacitor

The stabilization of the main regulator is achieved by connecting an external capacitor  $C_{VCOUT}$  to the VCOUT pin.  $C_{VCOUT}$  is specified in Table 6. General operating conditions.

Care should be taken to limit the series inductance to less than 15 nH.

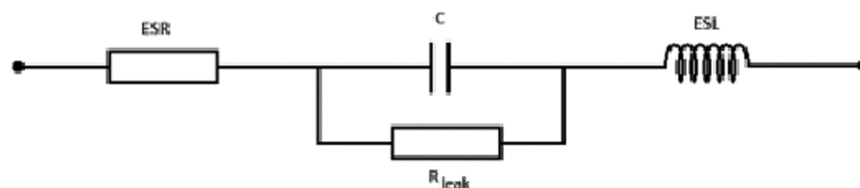
**Figure 25. External capacitor CVOUT**

### 5.3.2 Supply current characteristics

The STNRGPFx2 current consumption is declared based on, for example, an application where the application firmware is loaded and running.

**Table 8. Supply current characteristics**

Symbol	Parameter	Test condition	Min.	Typ. <sup>(1)</sup>	Max. <sup>(1)</sup>	Unit
$V_{DD}/V_{DDA}$ SECTION: current consumption						

Symbol	Parameter	Test condition	Min.	Typ. <sup>(1)</sup>	Max. <sup>(1)</sup>	Unit
I <sub>DD(RUN)</sub>	Total current consumption	V <sub>DD</sub> /V <sub>DDA</sub> = 5 V		28	34	mA

1. Test conditions: data based on characterization results not tested in production. Temperature operating: T<sub>A</sub> = 25 °C. Device in run mode.

### 5.3.3 Memory characteristics

Flash program and memory/data E<sup>2</sup>PROM.

General conditions: T<sub>A</sub> = -40 °C to 105 °C.

**Table 9. Flash program memory/data E<sup>2</sup>PROM**

Symbol	Parameter	Conditions	Min <sup>(1)</sup>	Typ <sup>(1)</sup>	Max <sup>(1)</sup>	Unit
t <sub>PROG</sub>	Standard programming time (including erase) for byte/word/block			6	6.6	ms
	Fast programming time for 1 block (128 bytes)			3	3.3	
t <sub>ERASE</sub>	Erase time for 1 block (128 bytes)			3	3.3	
NWE	Erase/write cycles <sup>(2)</sup> (program memory)	T <sub>A</sub> = 25 °C	10K			Cycles
	Erase/write cycles <sup>(2)</sup> (data memory)	T <sub>A</sub> = 85 °C	100K			
		T <sub>A</sub> = 105 °C	35K			
t <sub>RET</sub>	Data retention (program memory) after 10K erase/write cycles at T <sub>A</sub> = 25 °C	T <sub>RET</sub> = 85 °C	15			Years
	Data retention (program memory) after 10K erase/write cycles at T <sub>A</sub> = 25 °C	T <sub>RET</sub> = 105 °C	11			
	Data retention (data memory) after 100K erase/write cycles at T <sub>A</sub> = 85 °C	T <sub>RET</sub> = 85 °C	15			
	Data retention (data memory) after 35K erase/write cycles at T <sub>A</sub> = 105 °C	T <sub>RET</sub> = 105 °C	6			
I <sub>DDPRG</sub>	Supply current during program and erase cycles	-40 °C ≤ T <sub>A</sub> ≤ 105 °C		2		mA

1. Data based on characterization results, not tested in production.

2. The physical granularity of the memory is 4 bytes, so cycling is performed on 4 bytes even when a write/erase operation addresses a single byte.

### 5.3.4 Input/output specifications

The STNRGPFx2 device includes three different I/O types:

- Normal I/Os (O or I);
- Fast I/O (OP);
- High speed I/O (CLOCK).

The STNRGPFx2 I/Os are designed to withstand the current injection. For the negative injection current of 4 mA, the resulting leakage current in the adjacent input does not exceed 1 μA

### 5.3.5 I/O port pin characteristics

Subject to general operating conditions for V<sub>DD</sub> and T<sub>A</sub> unless otherwise specified. Unused input pins should not be left floating.

**Table 10. Voltage DC characteristics**

Symbol	Description	Min <sup>(1)</sup>	Typ	Max <sup>(1)</sup>	Unit
V <sub>IL</sub>	Input low voltage	-0.3	-	0.3 x V <sub>DD</sub>	V
V <sub>IH</sub>	Input high voltage <sup>(2)</sup>	0.7 x V <sub>DD</sub>	-	V <sub>DD</sub>	
V <sub>OL1</sub>	Output low voltage at 5 V <sup>(3)(4)</sup>	-	-	0.5	
V <sub>OL3</sub>	Output low voltage high sink at 5 V <sup>(2)</sup> , <sup>(5)</sup>	-	-	0.6	
V <sub>OH1</sub>	Output high voltage at 5 V <sup>(3)(4)</sup>	V <sub>DD</sub> -0.5	-	-	
V <sub>OH3</sub>	Output high voltage high sink at 5 V <sup>(2)</sup> , <sup>(5)</sup>	V <sub>DD</sub> -0.6	-	-	
H <sub>VS</sub>	Hysteresis input voltage <sup>(6)</sup>	0.1 x V <sub>DD</sub>	-	-	
R <sub>PU</sub>	Pull-up resistor	30	45	60	kΩ

1. Data based on characterization result, not tested in production.
2. Input signals can't be exceeded V<sub>DDX</sub> (V<sub>DDX</sub> = V<sub>DD</sub>, V<sub>DDA</sub>).
3. The parameter applicable to signals on pins 14, 15, 20, 21, 22 and 23.
4. The parameter applicable to signals on pins 1, 4, 5, 8 16 and 19.
5. The parameter applicable to the signal on pin 2.
6. Applicable to pins 3, 6, 7, 17 and 18.

**Table 11. Current DC characteristics**

Symbol	Description	Min	Typ	Max <sup>(1)</sup>	Unit
I <sub>OL1</sub>	Standard output low level current at 5 V and V <sub>OL1</sub> <sup>(2)(3)</sup>	-	-	3	mA
I <sub>OLhs1</sub>	High sink output low level current at 5 V and V <sub>OL3</sub> <sup>(2)(4)</sup>	-	-	7.5	
I <sub>OH1</sub>	Standard output high level current at 5 V and V <sub>OH1</sub> <sup>(2)(3)</sup>	-	-	3	
I <sub>OHhs1</sub>	High sink output high level current at 5 V and V <sub>OH3</sub> <sup>(2)(4)</sup>	-	-	7.5	
I <sub>LKg</sub>	Input leakage current digital - analog V <sub>SS</sub> ≤ V <sub>IN</sub> ≤ V <sub>DD</sub> <sup>(5)</sup>	-	-	± 1	μA
I <sub>_Inj</sub>	Injection current <sup>(6)(7)</sup>	-	-	± 4	mA
ΣI <sub>_Inj</sub>	Total injection current sum of all I/O and control pins <sup>(6)</sup>	-	-	± 20	

1. Data based on characterization result, not tested in production.
2. The parameter applicable to signals on pins 14, 15, 20, 21, 22 and 23.
3. The parameter applicable to signals on pins 1, 4, 5, 8 16 and 19.
4. The parameter applicable to the signal on pin 2.
5. Applicable to pins 3, 6, 7, 17 and 18.
6. Maximum value must never be exceeded.
7. Negative injection current on pins 31, 32, 33 and 34 must be avoided. It has impact on the measurement section.

### 5.3.6 Typical output level curves

This section shows the typical output voltage level curves measured on a single output pin for the three-pad family present in the STNRGPFx2 devices.

#### Normal I/Os

These pads are associated with the O type pins.

Figure 26.  $V_{OH}$  normal pin

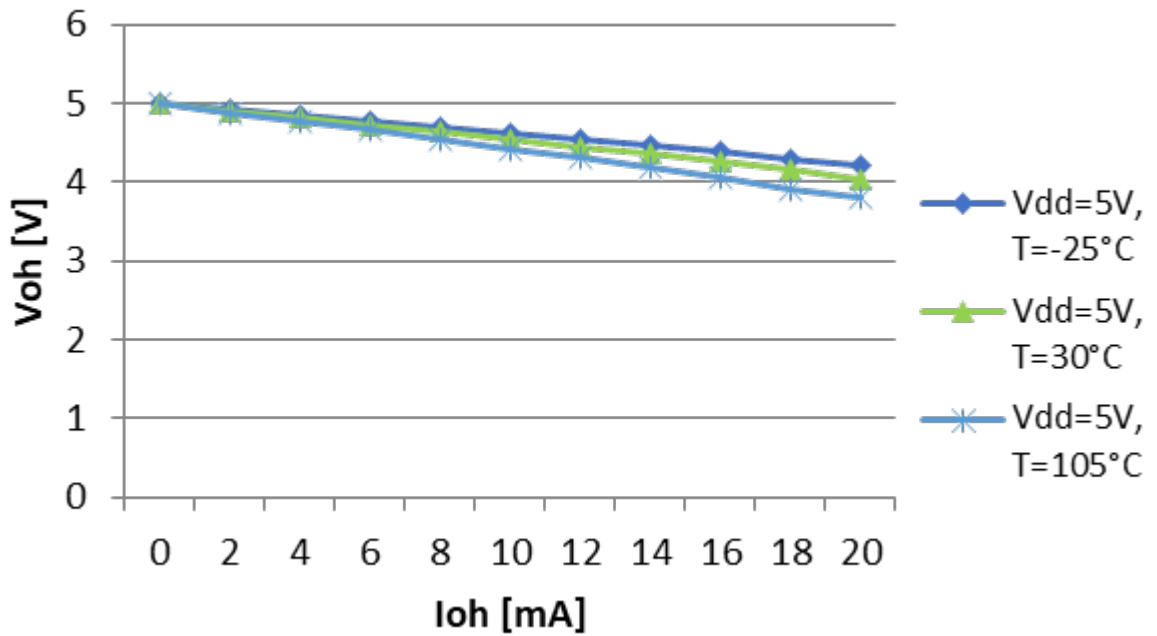
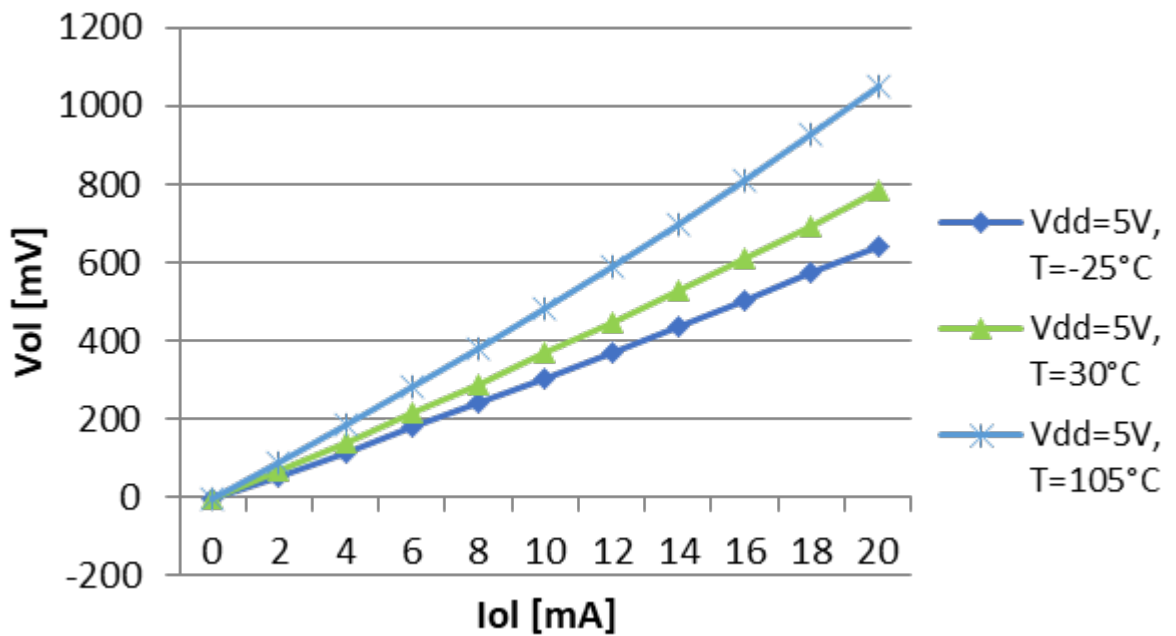

Figure 27.  $V_{OL}$  normal pin



**Fast I/Os**

These pads are associated with the OP type pins.

Figure 28.  $V_{OH}$  fast I/Os pins

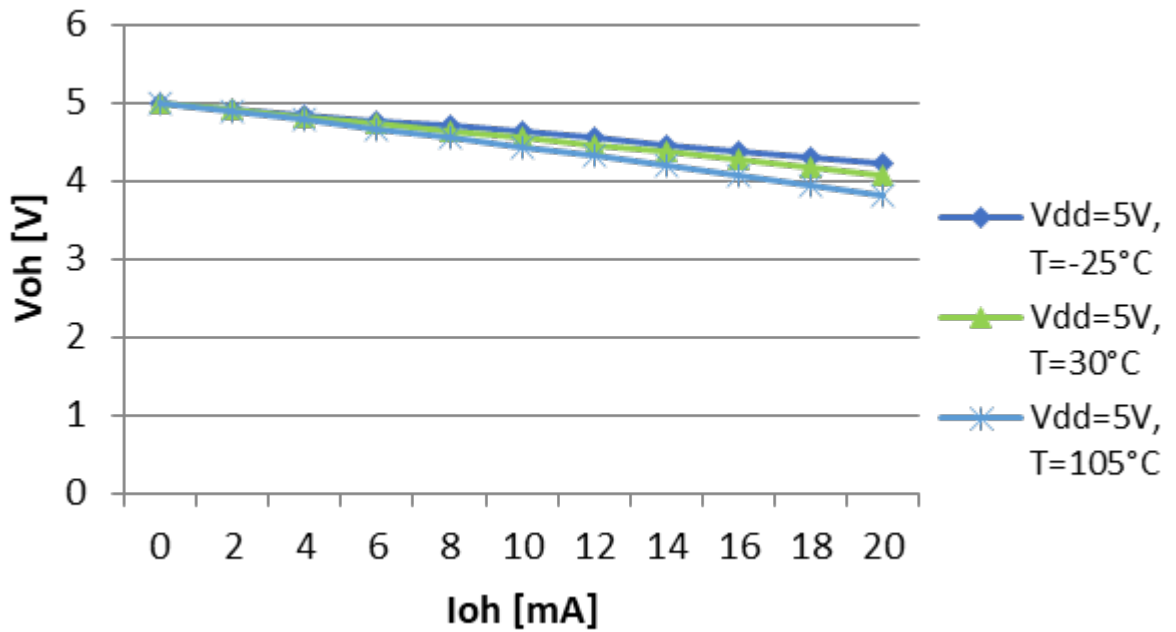
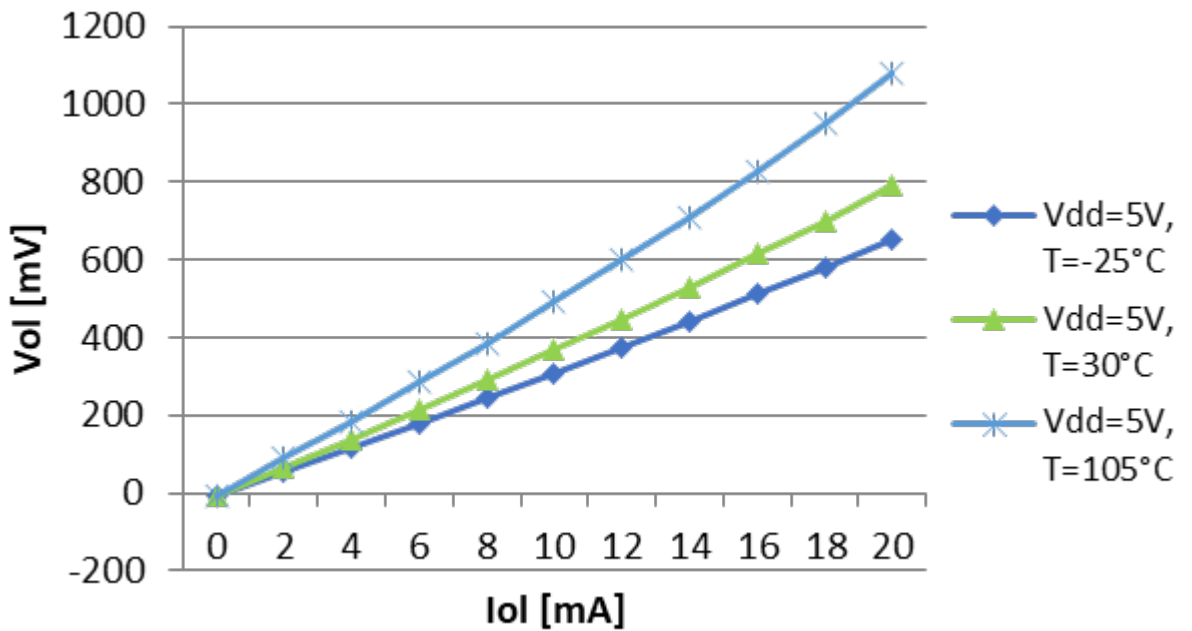

Figure 29.  $V_{OL}$  fast I/Os pins



**Output CLOCK**

This pad is associated with the OUTPUT CLOCK pin.

Figure 30.  $V_{OH}$  CLOCK pin

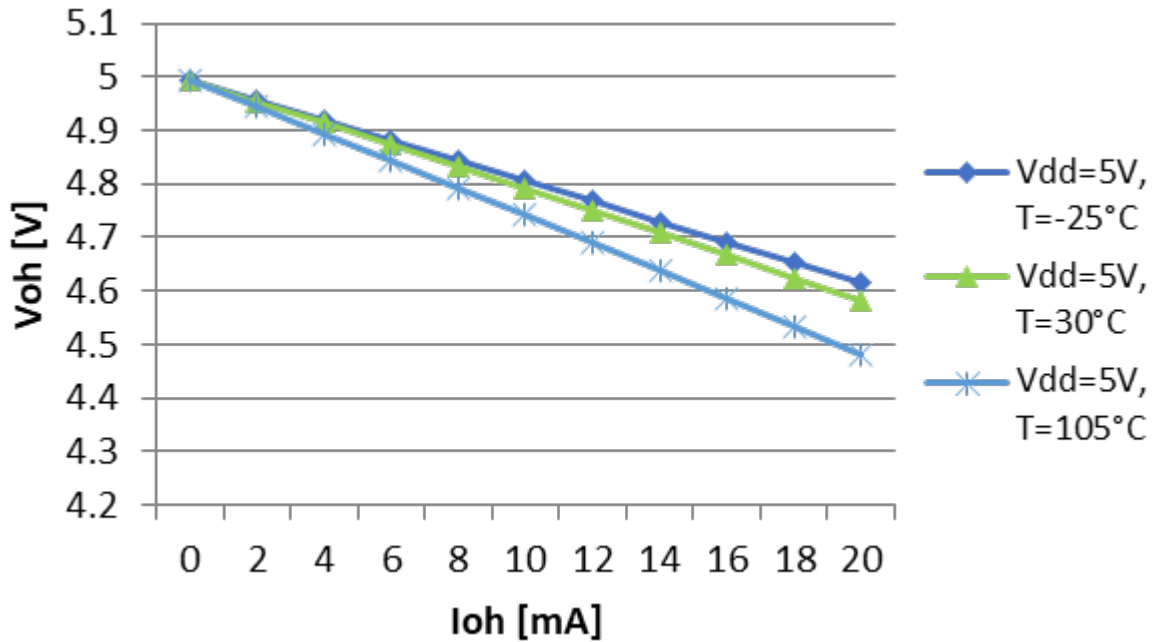
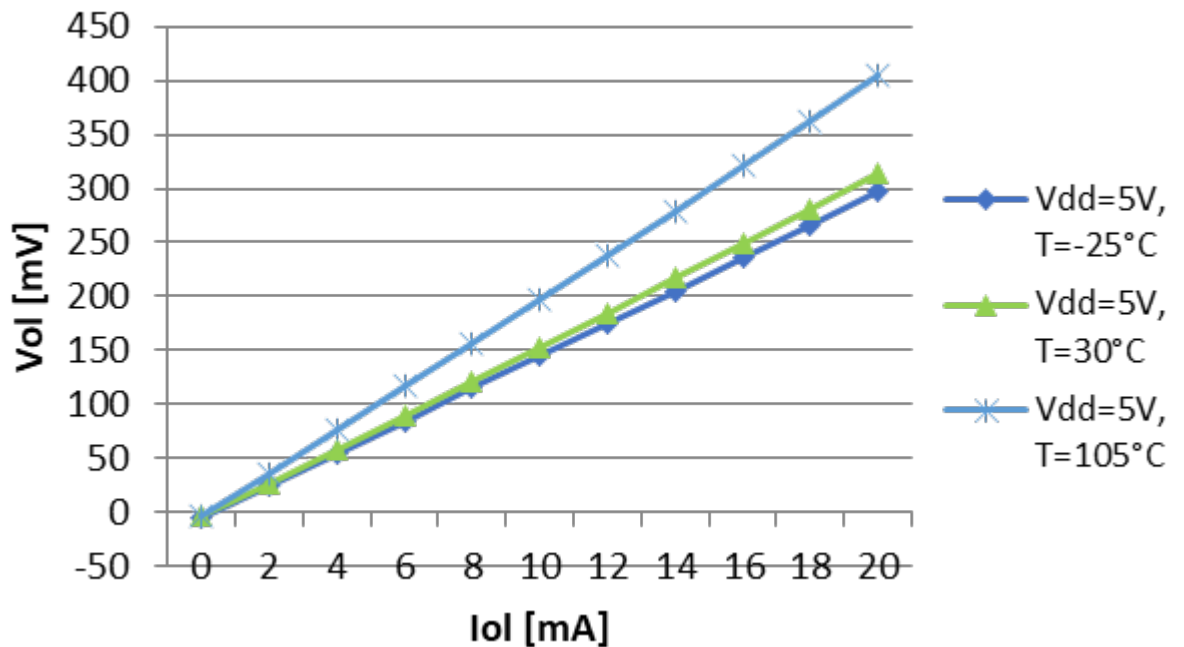

Figure 31.  $V_{OL}$  CLOCK pin



### 5.3.7 Reset pin characteristics

Subject to general operating conditions for  $V_{DD}$  and  $T_A$  unless otherwise specified.

**Table 12. NRST pin characteristics**

Symbol	Parameter	Conditions	Min <sup>(1)</sup>	Typ	Max <sup>(1)</sup>	Unit
V <sub>IL(NRST)</sub>	NRST input low level voltage <sup>(1)</sup>		-0.3		0.3 x V <sub>DD</sub>	V
V <sub>IH(NRST)</sub>	NRST input high level voltage <sup>(1)</sup>		0.7 x V <sub>DD</sub>		V <sub>DD</sub> + 0.3	
V <sub>OL(NRST)</sub>	NRST output low level voltage <sup>(1)</sup>	I <sub>OL</sub> = 2 mA			0.5	
R <sub>PU(NRST)</sub>	NRST pull-up resistor <sup>(2)</sup>		30	40	60	kΩ
t <sub>IFP(NRST)</sub>	NRST input filtered pulse <sup>(3)</sup>				75	ns
t <sub>INFP(NRST)</sub>	NRST not input filtered pulse <sup>(3)</sup>		500			
t <sub>OP(NRST)</sub>	NRST output filtered pulse <sup>(3)</sup>		15			μs

1. Data based on characterization results, not tested in production.
2. The RPU pull-up equivalent resistor is based on a resistive transistor.
3. Data guaranteed by design, not tested in production.

## 5.4 Analog input characteristics

### 5.4.1 Measurement section

Subject to general operating conditions for V<sub>DDA</sub> and T<sub>A</sub> unless otherwise specified.  
 It applies to the [MI] class.

**Table 13. Measurement pin characteristics**

Symbol	Parameter	Conditions	Min.	Typ.	Max.	Unit
RIN	Input impedance	-	1	-	-	M
VIN	Measurement range	-	0	-	1.25 <sup>(1)</sup>	V
Vref	Measure reference voltage <sup>(2)</sup>	-	-	1.25		

1. Maximum input analog voltage cannot exceed V<sub>DDA</sub>.
2. Reference voltage at T<sub>A</sub> = 25 °C.

### 5.4.2 Analog section

In Table 14. Analog comparator characteristics are reported.  
 It applies to the [AI] class.

**Table 14. Analog comparator characteristics**

Symbol	Parameter	Conditions	Min. <sup>(1)</sup>	Typ.	Max. <sup>(1)</sup>	Unit
V <sub>CPP01</sub>	Comparator CP0,1 positive input voltage range	-40 °C ≤ TA ≤ 105 °C	0	-	1.23 <sup>(2)</sup>	V
V <sub>CPP23</sub>	Comparator CP2,3 positive input voltage range	-40 °C ≤ TA ≤ 105 °C	0	-	2 <sup>(3)</sup>	V
V <sub>CPM23</sub>	Comparator CP2,3 negative external input voltage range	-40 °C ≤ TA ≤ 105 °C	0	-	2 <sup>(3)</sup>	V
C <sub>IN</sub>	Input capacitance	-	-	3	-	pF
V <sub>offset</sub>	Comparator offset error	-	-	-	15	mV
t <sub>COMP</sub>	Comparison delay time	-	-	-	50 <sup>(4)</sup>	ns

1. Data based on characterization results, not tested in production.
2. Maximum analog input voltage for comparators CP0 and CP1.
3. Maximum analog input voltage for comparators CP2 and CP3.
4. The overdrive voltage is ± 50 mV.

## 5.5 EMC characteristics

### 5.5.1 Electrostatic discharge (ESD)

Electrostatic discharges (3 positive then 3 negative pulses separated by 1 second) are applied to the pins of each sample according to each pin combination. The sample size depends on the number of supply pins in the device [3 parts \* (n + 1) supply pin].

**Table 15. ESD absolute maximum ratings (Data based on characterization results, not tested in production).**

Symbol	Ratings	Conditions	Maximum value	Unit
V <sub>ESD(HBM)</sub>	Electrostatic discharge voltage (human body model)	T <sub>A</sub> = 25 °C, conforming to JEDEC/JESD22-A114E	2000	V
V <sub>ESD(CDM)</sub>	Electrostatic discharge voltage (charge device model)	T <sub>A</sub> = 25 °C, conforming to ANSI/ESD STM 5.3.1 ESDA	500	
V <sub>ESD(MM)</sub>	Electrostatic discharge voltage (machine model)	T <sub>A</sub> = 25 °C, conforming to JEDEC/JESD-A115-A	200	

### 5.5.2 Static latch-up

Two complementary static tests are required on 10 parts to assess the latch-up performance.

A supply overvoltage (applied to each power supply pin) and a current injection (applied to each input, output and configurable I/O pin) are performed on each sample. This test conforms to the EIA/JESD78 IC latch-up standard.

**Table 16. Electrical sensitivity**

Symbol	Parameter	Conditions	Level
LU	Static latch-up class	T <sub>A</sub> = 105 °C	A



## 6 Thermal data

The STNRGPFx2 functionality cannot be guaranteed when the device, in operation, exceeds the maximum chip junction temperature ( $T_{Jmax}$ ).

### Equation 2

$$T_{Jmax} = T_{Amax} + (P_{Dmax} \times \Theta_{JA})$$

Where:

$T_{Amax}$  is the maximum ambient temperature in °C

$\Theta_{JA}$  is the package junction to ambient thermal resistance in °C/W

$P_{Dmax}$  is the sum of  $P_{INTmax}$  and  $P_{I/Omax}$  ( $P_{Dmax} = P_{INTmax} + P_{I/Omax}$ )

$P_{INTmax}$  is the product of  $I_{DD}$  and  $V_{DD}$ , expressed in watts. This is the maximum chip internal power.

$P_{I/Omax}$  represents the maximum power dissipation on output pins where:

$$P_{I/Omax} = (V_{OL} \times I_{OL}) + \sum [(V_{DD} - V_{OH}) \times I_{OH}],$$

taking into account the actual  $V_{OL/IOL}$  and  $V_{OH/IOH}$  of the I/Os at the low and high level.

**Table 17. Package thermal characteristics**

Symbol	Package thermal characteristics	Value	Unit
JA	TSSOP38 - thermal resistance junction to ambient <sup>(1)</sup>	80	°C/W

1. Thermal resistance is based on the JEDEC JESD51-2 with the 4-layer PCB in natural convection

## 7 Package information

In order to meet environmental requirements, ST offers these devices in different grades of **ECOPACK** packages, depending on their level of environmental compliance. ECOPACK specifications, grade definitions and product status are available at: [www.st.com](http://www.st.com). ECOPACK is an ST trademark.

### 7.1 TSSOP38 package information

**Figure 32. TSSOP38 package outline**

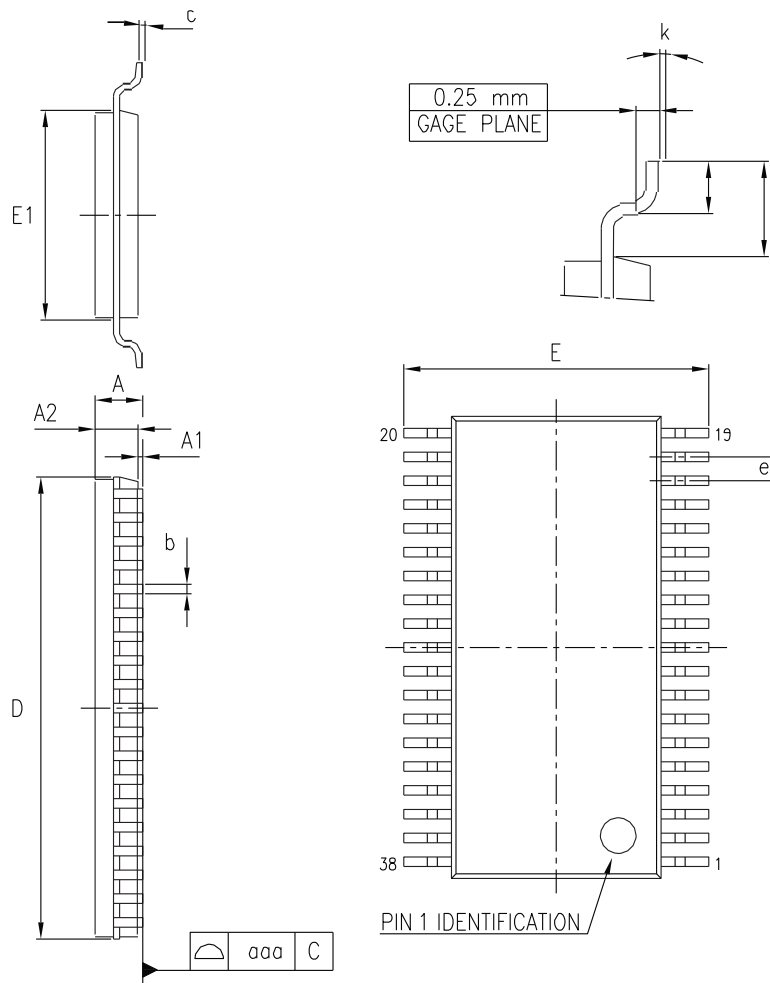

0117861\_C

**Table 18. TSSOP38 package mechanical data (“TSSOP” stands for “Thin Shrink Small Outline Package”)**

Symbol	Dimensions (mm)		
	Min.	Typ.	Max
A	-	-	1.20
A1	0.05	-	0.15
A2	0.80	1.00	1.05
b	0.17	-	0.27

Symbol	Dimensions (mm)		
	Min.	Typ.	Max
c	0.09	-	0.20
D <sup>(1)</sup>	9.60	9.70	9.80
E	6.20	6.40	6.60
E1 <sup>(1)</sup>	4.30	4.40	4.50
e	-	0.50	-
L	0.45	0.60	0.75
L1	-	1.00	-
k	0	-	8
aaa	-	-	0.10

1. "Dimensions "D" and "E1" do not include mold flash or protrusions. Mold flash or protrusions shall not exceed 0.15 mm per side.

## 8 STNRGPF02/12 development tools

The development tools for the STNRGPFx2 are provided by:

- **eDesign Suite** This tool uses a graphical user interface to guide customers step-by-step to implementation of a solution in accordance with their specifications. The tool gives users the ability to navigate through an interactive and hierarchical schematic, providing additional information like Bode diagrams for both the current and the voltage loop, power loss calculation, bill of material, and easy shortcuts for datasheets and product folder web pages. The final output of this process is a complete design, with a binary file that contains the optimized firmware for that specific application, which can be uploaded to the STNRGPFx2 device using the UART serial communication port.
- **STNRG LOADER** This tool permits the user to download the binary code from the eDesign Suite.

## 9 Ordering information

Order codes	Package	Packaging
STNRGPF02	TSSOP38	Tube
STNRGPF02TR		Tape and reel
STNRGPF12		Tube
STNRGPF12TR		Tape and reel

## Revision history

**Table 19. Document revision history**

Date	Version	Changes
04-May-2019	1	Initial release.
23-Jun-2020	2	Added STNRGPF02

## Contents

<b>1</b>	<b>General description</b>	<b>3</b>
1.1	Inrush current limiter function description	3
1.1.1	Inrush current limiter function with resistive element (STNRGPF02 only)	3
1.1.2	Inrush current limiter function with controlled bridge (STNRGPF12 only)	4
<b>2</b>	<b>STNRGPF02/12 control architecture</b>	<b>5</b>
<b>3</b>	<b>STNRGPF02/12 blocks diagram</b>	<b>6</b>
3.1	Voltage and current loops	6
3.2	Measurements section	7
3.2.1	AC input voltage measurement	7
3.2.2	Ambient temperature measurements	8
3.2.3	Output Current measurement	9
3.2.4	Output voltage sensing	9
3.2.5	Channel current measurement	9
3.3	Analog comparators section	10
3.4	PWM Section: driving & interleaving	11
3.5	Programming section	12
3.6	Status indicator	13
3.7	Start-up & Inrush Current Limiter function	13
3.7.1	Inrush Current Limiter Function	14
3.7.2	PFC Soft Power-ON	15
3.7.3	Fan control	16
<b>4</b>	<b>Pinout and pin description</b>	<b>18</b>
4.1	Pinout	18
4.2	Pin description	19
4.3	Input/output specification	21
<b>5</b>	<b>Electrical characteristics</b>	<b>22</b>
5.1	Parameter conditions	22
5.1.1	Minimum and maximum values	22
5.1.2	Typical values	22
5.1.3	Typical curves	22

5.1.4	Typical current consumption . . . . .	22
5.1.5	Loading capacitors . . . . .	22
5.1.6	Pin output voltage . . . . .	23
<b>5.2</b>	<b>Absolute maximum ratings . . . . .</b>	<b>23</b>
<b>5.3</b>	<b>Operating conditions . . . . .</b>	<b>24</b>
5.3.1	VOUT external capacitor . . . . .	25
5.3.2	Supply current characteristics . . . . .	25
5.3.3	Memory characteristics . . . . .	26
5.3.4	Input/output specifications . . . . .	26
5.3.5	I/O port pin characteristics . . . . .	26
5.3.6	Typical output level curves . . . . .	27
5.3.7	Reset pin characteristics . . . . .	30
<b>5.4</b>	<b>Analog input characteristics . . . . .</b>	<b>31</b>
5.4.1	Measurement section . . . . .	31
5.4.2	Analog section . . . . .	31
<b>5.5</b>	<b>EMC characteristics . . . . .</b>	<b>32</b>
5.5.1	Electrostatic discharge (ESD) . . . . .	32
5.5.2	Static latch-up . . . . .	32
<b>6</b>	<b>Thermal data . . . . .</b>	<b>33</b>
<b>7</b>	<b>Package information . . . . .</b>	<b>34</b>
7.1	TSSOP38 package information . . . . .	34
<b>8</b>	<b>STNRGPF02/12 development tools . . . . .</b>	<b>36</b>
<b>9</b>	<b>Ordering information . . . . .</b>	<b>37</b>
	<b>Revision history . . . . .</b>	<b>38</b>
	<b>Contents . . . . .</b>	<b>39</b>
	<b>List of tables . . . . .</b>	<b>41</b>
	<b>List of figures . . . . .</b>	<b>42</b>



## List of tables

<b>Table 1.</b>	Pin description . . . . .	19
<b>Table 2.</b>	Legend of the pins . . . . .	21
<b>Table 3.</b>	Voltage characteristics . . . . .	23
<b>Table 4.</b>	Current characteristics . . . . .	24
<b>Table 5.</b>	Thermal characteristics . . . . .	24
<b>Table 6.</b>	General operating conditions . . . . .	24
<b>Table 7.</b>	Operating conditions at power-up/power-down . . . . .	25
<b>Table 8.</b>	Supply current characteristics . . . . .	25
<b>Table 9.</b>	Flash program memory/data E <sup>2</sup> PROM . . . . .	26
<b>Table 10.</b>	Voltage DC characteristics . . . . .	27
<b>Table 11.</b>	Current DC characteristics . . . . .	27
<b>Table 12.</b>	NRST pin characteristics . . . . .	31
<b>Table 13.</b>	Measurement pin characteristics . . . . .	31
<b>Table 14.</b>	Analog comparator characteristics . . . . .	32
<b>Table 15.</b>	ESD absolute maximum ratings (Data based on characterization results, not tested in production). . . . .	32
<b>Table 16.</b>	Electrical sensitivity . . . . .	32
<b>Table 17.</b>	Package thermal characteristics . . . . .	33
<b>Table 18.</b>	TSSOP38 package mechanical data (“TSSOP” stands for “Thin Shrink Small Outline Package”) . . . . .	34
<b>Table 19.</b>	Document revision history . . . . .	38

## List of figures

<b>Figure 1.</b>	STNRGPF02: Inrush current limiter with resistor in series to output capacitor . . . . .	4
<b>Figure 2.</b>	STNRFPF12: Inrush current limiter with controlled rectifier bridge . . . . .	4
<b>Figure 3.</b>	STNRGPF12 control scheme . . . . .	5
<b>Figure 4.</b>	STNRGPFx2 Block diagram . . . . .	6
<b>Figure 5.</b>	Voltage loop and current reference . . . . .	7
<b>Figure 6.</b>	V <sub>in</sub> , Measurement. . . . .	8
<b>Figure 7.</b>	Temperature measurement . . . . .	8
<b>Figure 8.</b>	V <sub>in</sub> , I <sub>out</sub> and V <sub>out</sub> Measurement . . . . .	9
<b>Figure 9.</b>	Channel current measurement . . . . .	10
<b>Figure 10.</b>	Analog comparators section . . . . .	11
<b>Figure 11.</b>	Driving & interleaving. . . . .	12
<b>Figure 12.</b>	Programming section. . . . .	13
<b>Figure 13.</b>	Status Indicator . . . . .	13
<b>Figure 14.</b>	Start-Up sequence . . . . .	14
<b>Figure 15.</b>	Inrush Current Limiter function with limiter resistor and bypass relay . . . . .	14
<b>Figure 16.</b>	Digital Inrush Current Limiter function with a semi-controlled input bridge. . . . .	15
<b>Figure 17.</b>	Digital Inrush Current Limiter function: sequence of driving of the SCR . . . . .	15
<b>Figure 18.</b>	Running mode or Burst mode . . . . .	16
<b>Figure 19.</b>	Fan Control function . . . . .	17
<b>Figure 20.</b>	STNRGPF12 - TSSOP38 pinout . . . . .	18
<b>Figure 21.</b>	STNRGPF02 - TSSOP38 pinout . . . . .	19
<b>Figure 22.</b>	Supply current measurement conditions. . . . .	22
<b>Figure 23.</b>	Pin loading conditions . . . . .	23
<b>Figure 24.</b>	Pin input voltage. . . . .	23
<b>Figure 25.</b>	External capacitor C <sub>VOUT</sub> . . . . .	25
<b>Figure 26.</b>	V <sub>OH</sub> normal pin. . . . .	28
<b>Figure 27.</b>	V <sub>OL</sub> normal pin . . . . .	28
<b>Figure 28.</b>	V <sub>OH</sub> fast I/Os pins . . . . .	29
<b>Figure 29.</b>	V <sub>OL</sub> fast I/Os pins . . . . .	29
<b>Figure 30.</b>	V <sub>OH</sub> CLOCK pin . . . . .	30
<b>Figure 31.</b>	V <sub>OL</sub> CLOCK pin . . . . .	30
<b>Figure 32.</b>	TSSOP38 package outline . . . . .	34

**IMPORTANT NOTICE – PLEASE READ CAREFULLY**

STMicroelectronics NV and its subsidiaries (“ST”) reserve the right to make changes, corrections, enhancements, modifications, and improvements to ST products and/or to this document at any time without notice. Purchasers should obtain the latest relevant information on ST products before placing orders. ST products are sold pursuant to ST’s terms and conditions of sale in place at the time of order acknowledgement.

Purchasers are solely responsible for the choice, selection, and use of ST products and ST assumes no liability for application assistance or the design of Purchasers’ products.

No license, express or implied, to any intellectual property right is granted by ST herein.

Resale of ST products with provisions different from the information set forth herein shall void any warranty granted by ST for such product.

ST and the ST logo are trademarks of ST. For additional information about ST trademarks, please refer to [www.st.com/trademarks](http://www.st.com/trademarks). All other product or service names are the property of their respective owners.

Information in this document supersedes and replaces information previously supplied in any prior versions of this document.

© 2020 STMicroelectronics – All rights reserved