

RECOMMENDED PCB LAYOUT
COMPONENT SIDE

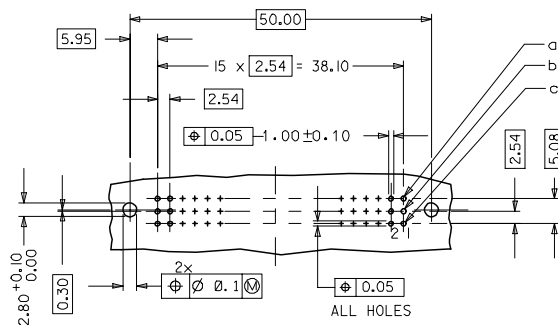

WITH MOUNTING CLIPS

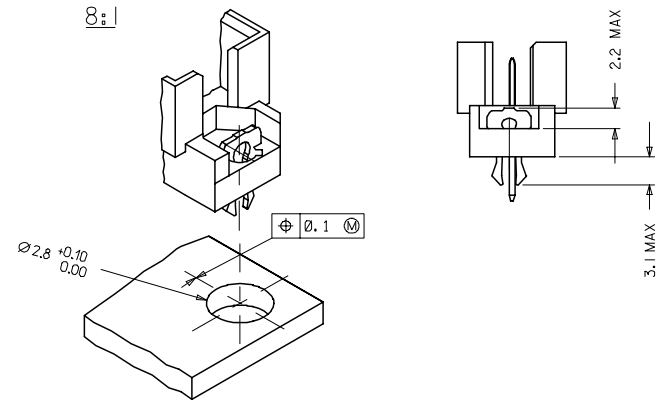

NOTES:

- MATERIALS: THERMOPLASTIC POLYESTER, GLASS FILLED, UL94V-0, COLOUR: PEBBLE GREY RAL 7032
TERMINAL - BRASS
MOUNTING CLIP: STEEL
- FINISH: TERMINAL:-
CONTACT AREA
PERFORMANCE LEVEL : SELECTIVE GOLD (Au), THICKNESS = 0.40 MICROMETER
OVER NICKEL, THICKNESS = 1.50 MICROMETER
TERMINATION AREA:
SELECTIVE TIN, THICKNESS = 2.5 MICROMETER
OVER NICKEL, THICKNESS = 1.50 MICROMETER OVERALL
- MOUNTING CLIP:-
TIN (Sn), THICKNESS = 5-10 MICROMETER,
OVER NICKEL (Ni), THICKNESS = 2.5 MICROMETER
- FOR NON MOUNTING CLIP OPTION, CONNECTOR TO BE SECURED WITH RIVETS: 2 TUBULAR RIVETS 2.5 x 0.3 ... DIN 7340
SCREWS: 2 CHEESEHEAD SCREWS M2.5 x ... DIN 84 AND 2 HEXAGONAL NUTS M2.5 DIN 934
- MATERIAL NUMBER, BATCH CODE, UL AND CSA MARKING TO BE PRINTED ON THE CONNECTOR
- CUT FACE OF TIP WITHOUT PLATING PERMITTED
- PRODUCT SPECIFICATION PS : 36511-001

RoHS COMPLIANT

ENTER DESCRIPTION ELC.MC.12007-05/14 DRAWINGS CHECKED BY APPROVED BY DATE 2007/06/27 2007/06/27 2007/06/27	QUALITY SYMBOLS ▽=0 ▽=0 ▽=0	GENERAL TOLERANCES (UNLESS SPECIFIED)		DIMENSION STYLE MM ONLY		SCALE 2:1	DESIGN UNITS METRIC	THIRD ANGLE PROJECTION
		4 PLACES ± 0.15 ± --- 3 PLACES ± 0.05 ± --- 2 PLACES ± 0.1 ± --- 1 PLACE ± 0.15 ± ---	INCH ± --- ± --- ± --- ± ---	DRAWN BY SS	DATE 1999/09/24	TITLE ASSEMBLY, DIN 41612 R/2 MALE 48 POS SOLDER L = 2.9	MOLEX INCORPORATED	SHEET NO. 1 OF 2
DRAFT WHERE APPLICABLE MUST REMAIN WITHIN DIMENSIONS	SEE SHEET 2	MATERIAL NO. SD-36512-011	DOCUMENT NO.	THIS DRAWING CONTAINS INFORMATION THAT IS PROPRIETARY TO MOLEX INCORPORATED AND SHOULD NOT BE USED WITHOUT WRITTEN PERMISSION				

20	19	18	17	16	15	14	13	12	11	10	9	8	7	6	5	4	3	2	1
MATERIAL No.	MOLEX ENG No.	PERF LEVEL	PLATING	CONTACT SEQUENCE/ROW	DIM "L" MM	MOUNTING CLIP	FMLB												
36512-0196	MM-B1901-R480	REFER NOTE.2	Au + Ni	1.2.3...16 a+b+c	2.9	NO	NO												

DETAILY DETAILX

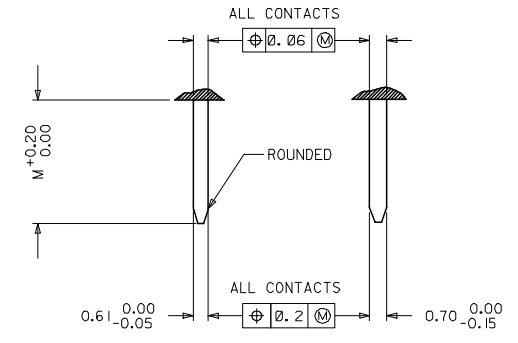

PRE MATING CONTACTS	5.4
NORMAL CONTACTS	4.8
	M

RoHS COMPLIANT

ENTER DESCRIPTION ELC INC. 12/07-05/14 2007/06/21 DRWNGS 2007/06/21 CHKD/PRASAD 2007/06/21 APPR/PRASAD 2007/06/21 A	QUALITY SYMBOLS 	GENERAL TOLERANCES (UNLESS SPECIFIED)		DIMENSION STYLE MM ONLY	SCALE 2:1	DESIGN UNITS METRIC	THIRD ANGLE PROJECTION		
		4 PLACES ± 0.15 ± --- ± ---	3 PLACES ± 0.05 ± --- ± ---	2 PLACES ± 0.1 ± --- ± ---	1 PLACE ± 0.15 ± --- ± ---	ANGULAR ± 2°	DRAWN BY SS 1999/09/24	DATE 1999/09/24	TITLE ASSEMBLY, DIN 41612 R/2 MALE 48 POS SOLDER L = 2.9
		DRAFT WHERE APPLICABLE MUST REMAIN WITHIN DIMENSIONS		SEE CHART	APPROVED BY GJ LOWE 1999/09/24	DATE 1999/09/24	MOLEX INCORPORATED	MATERIAL NO. SD-36512-011	DOCUMENT NO. SD-36512-011
				SIZE A 1	THIS DRAWING CONTAINS INFORMATION THAT IS PROPRIETARY TO MOLEX INCORPORATED AND SHOULD NOT BE USED WITHOUT WRITTEN PERMISSION		SHEET NO. 2 OF 2		