



PRODUCT SPECIFICATION

Attn: _____

SPEC. No: _____

DATE: Dec.17.2012

CUSTOMER PRODUCT NAME:
TDK PRODUCT NAME: WT-1005660-12K2-A6-G
APPROVED BY:
CUSTOMER COMMENT:
REMARK: Please sign back specification after customer conformation until 2weeks. If customer can't sign back specification, customer should be approved TDK specification.

TDK-EPC Corporation

Head Office Address:

1-13-1, Nihonbashi, Chuo-ku, Tokyo
103-0027 , Japan

SALES

MANAGER	SALES

ENGINEERING

APPROVED	CHECKED	ISSUED

Sales Office _____

Sales Tel. _____

PRODUCT	
---------	--

REVISED HISTORY

CUSTOMER PRODUCT NAME: _____

TDK PRODUCT NAME: **WT-1005660-12K2-A6-G**

NO.	REV.	REVISED CONTENT	REVISED REASON	DATE
1	0	To establish specification		2012.12.17

PRODUCT SPECIFICATION

TDK PRODUCT NAME:

WT-1005660-12K2-A6-G

SPEC. NO.

CUSTOMER PRODUCT NAME:

(1) Apperance & Dimensions (Unit: mm)

Weight: 46.7 g (Typ.)

TOP VIEW

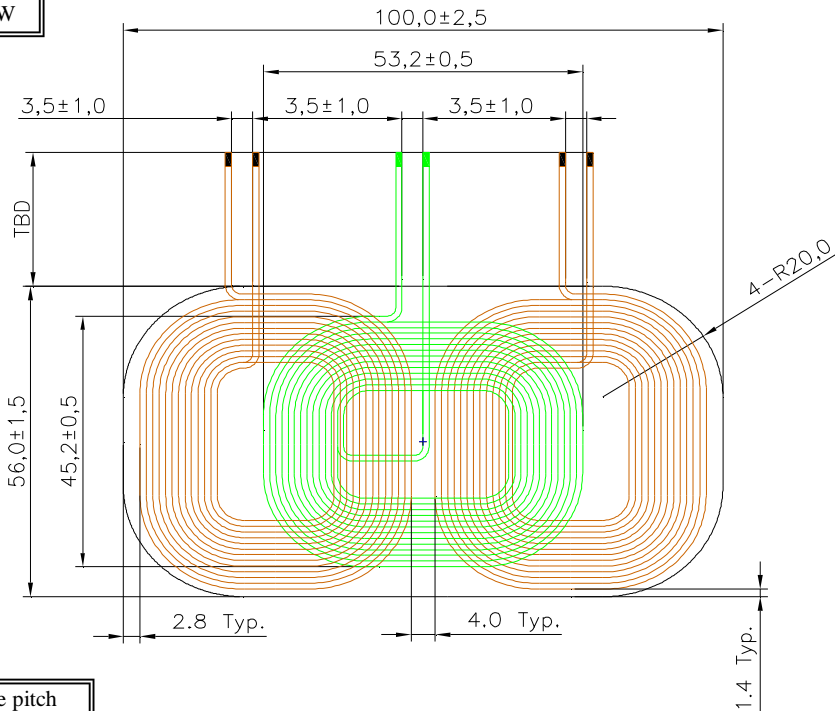

Lead wire pitch position

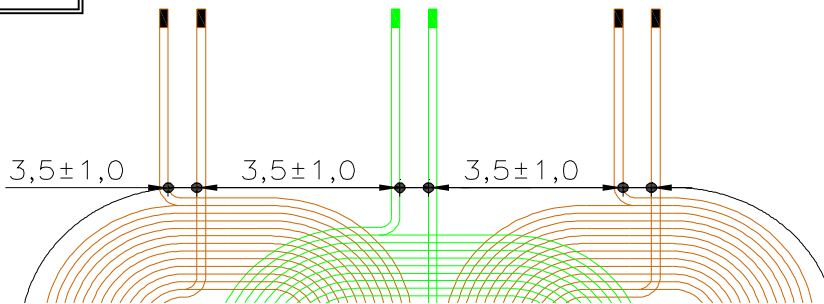

BOTTOM VIEW

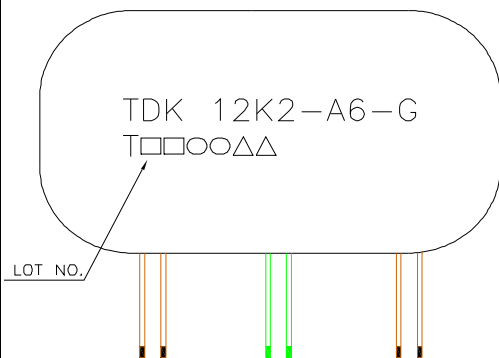

SIDE VIEW

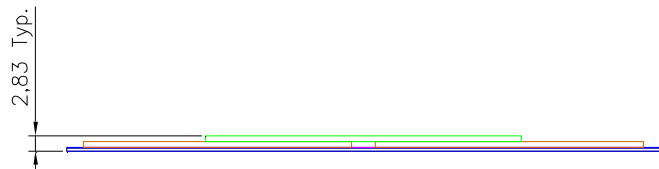

[Remarks]

1. Lead wire pitch is end of wire position, not output terminal.

2. Marking Content:

a. T: Manufacturing Centers

b. Lot No.: □ □ ○ ○ △ △

(1) (2) (3)

(1) Year: A.D. end number in double

(2) Month: Jan.(1), Feb.(02)...Dec.(12)

(3) Day: 01,02,03,...31.

PRODUCT SPECIFICATION

TDK PRODUCT NAME: WT-1005660-12K2-A6-G	SPEC. NO.	CUSTOMER PRODUCT NAME:
--	-----------	------------------------

(2) Air coil specification

Wire Diameter: $\phi 0.08\text{mm} \times 105$ (Type2 Wire)

Coil Turns: 12TS / 1 layer

(3) Electrical Characteristics

No.	Parameter	Specification	Test Instrument
1	Inductance	Coil 0	HP 4284A DIGITAL LCR METER or EQUIVALENT (@100kHz 1.0 Vrms)
		Coil 1	
		Coil 2	
2	Q Value	Coil 0	HP 4284A DIGITAL LCR METER or EQUIVALENT (@100kHz 1.0 Vrms)
		Coil 1	
		Coil 2	
3	DC Resistance	Coil 0	CHEN HWA 502A OHM METER or EQUIVALENT
		Coil 1	
		Coil 2	

* Remark:

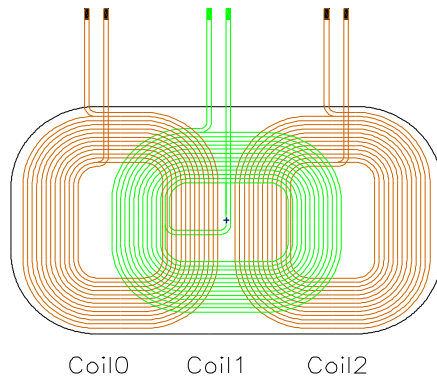

(4) Temperature Characteristics

No.	Parameter	Specification
1	Operating Temperature	-30~70°C
2	Storage Temperature	-40~85°C

(5) Application

1. The product fit in with RoHS rule.
2. The product fit in with Halogen-Free.
3. Reflow and dip-flow soldering can not used for this product.

PRODUCT SPECIFICATION

TDK PRODUCT NAME: WT-1005660-12K2-A6-G	SPEC. NO.	CUSTOMER PRODUCT NAME:
--	-----------	------------------------

(6) Reliability Conditions

No.	Parameter	Conditions	
1	Low Temperature (Storage)	(1) Temperature : $-40\pm 2^{\circ}\text{C}$ (2) Time : 240Hrs	
2	High Temperature (Storage)	(1) Temperature : $+85\pm 2^{\circ}\text{C}$ (2) Time : 240Hrs	
3	Thermal Shock	(1) Temperature : $-40\pm 5^{\circ}\text{C} / 30\text{min} \sim +85\pm 5^{\circ}\text{C} / 30\text{min}$ (2) Ambient Time : 5min (3) Times : 100cycles	
4	Vibration	Unpacked: (1) frequency: 10~500Hz sweep 1 octave wave / 1 min (2) Amplitude: 1.5mm (p-p) or 10G (3) Direction: X.Y.Z. direction (4) Time: X.Y.Z for 2 hours each.	
5	Temperature / Humidity (Storage)	(1) Temperature : $+60\pm 2^{\circ}\text{C}$ (2) Humidity: 90% RH. (3) Time: 240Hrs	
6	Temperature / Humidity (OP)	(1) Temperature : $+60\pm 2^{\circ}\text{C}$ (2) Humidity: 90% RH. (3) Time: 240Hrs (4) Current: DC 1.0A (5) Frequency: 100kHz	
7	Package Drop	(1) Drop the sample package in a carton box. (2) Height : 100 cm (3) Direction : 1corner, 3 edges, 6 faces (4) Drop time : 16 times	
8	ESD(HBM)	(1) Test Voltage: 1000V (2) Ambient: $25\pm 5^{\circ}\text{C}$ (3) Time: Negative / Positive each 1 time (4) Resistance: 1500 Ω (5) Capacitance: 100pF	
9	ESD(MM)	(1) Test Voltage: 100V (2) Ambient: $25\pm 5^{\circ}\text{C}$ (3) Time: Negative / Positive each 1 time (4) Capacitance: 200pF	

PRODUCT SPECIFICATION

TDK PRODUCT NAME: WT-1005660-12K2-A6-G	SPEC. NO.	CUSTOMER PRODUCT NAME:
--	-----------	------------------------

(7) Construction

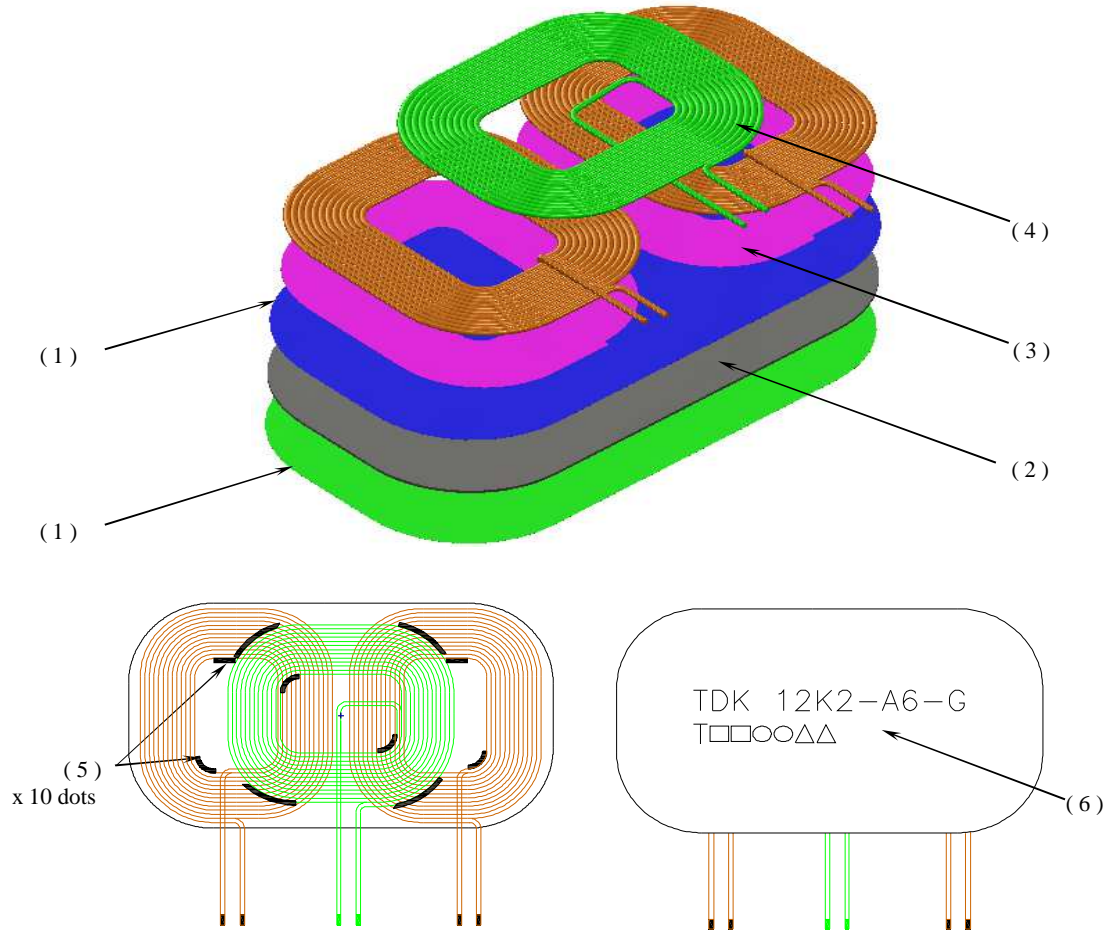

(8) Material List

No.	Material Name
1	PET Tape
2	Ferrite Sheet
3	Adhesive Tape
4	Air Coil
5	Glue
6	Ink

PRODUCT SPECIFICATION

TDK PRODUCT NAME: WT-1005660-12K2-A6-G	SPEC. NO.	CUSTOMER PRODUCT NAME:
--	-----------	------------------------

(9) Packing

- To stack the the Trays onto 4 Layers:
 - PS tray dimension: 326*329*11.0mm (REF.)
 - 6 Pcs / per PS tray (REF.)

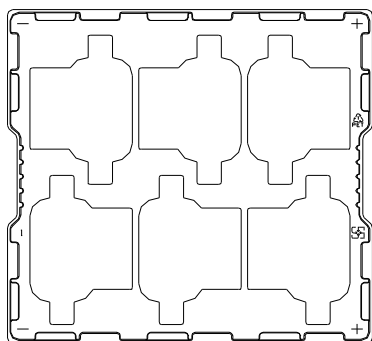

Total : 2x3=6pcs

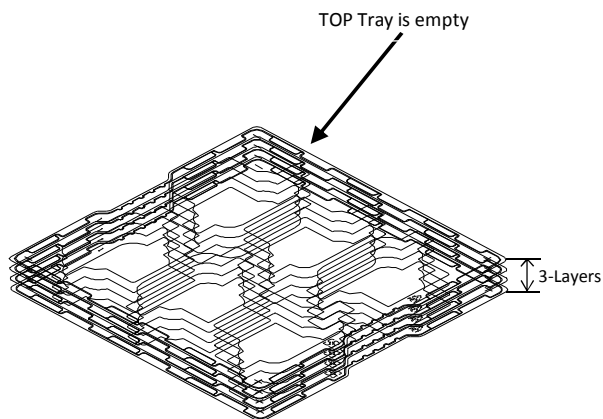

Total : 6x2=12pcs

- To put 2 Trays of products into the small Carton and affixing the out-going label on the outside .

- Small carton dimension: 331*337*33mm (REF.)
- 3 PS Trays / per small carton (PS tray of the top side is empty in the small carton)

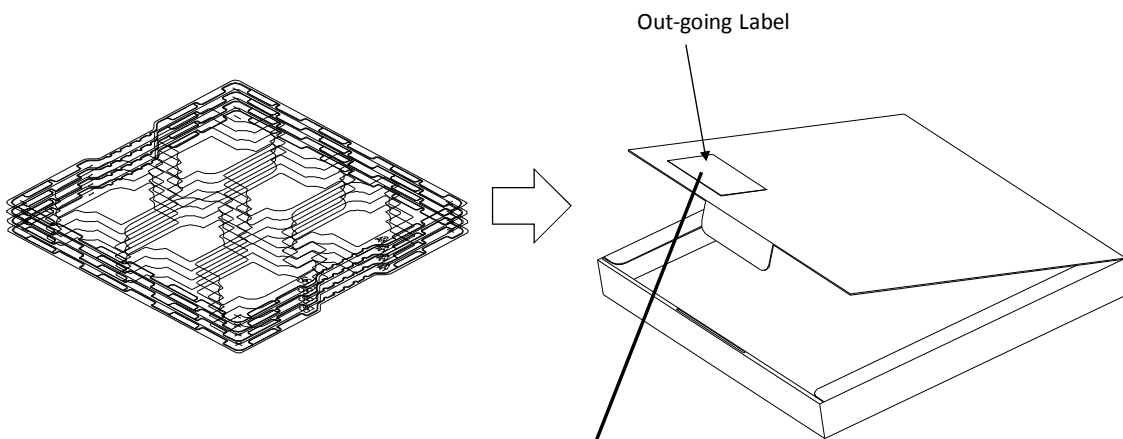

Out-going Label

PRODUCT SPECIFICATION

TDK PRODUCT NAME:

WT-1005660-12K2-A6-G

SPEC. NO.

CUSTOMER PRODUCT NAME:

3. To put 3 small carton into the Carton .

- Outer carton dimension: 347*340*124mm (REF.)
- 3 small cartons / per outer carton
- Total quantity : 36 Pcs (REF.)

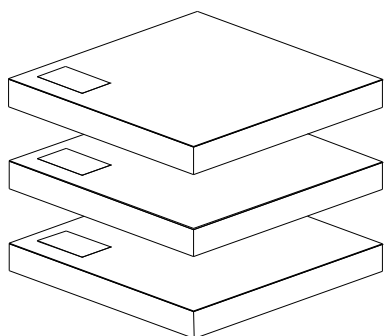

3 small cartons

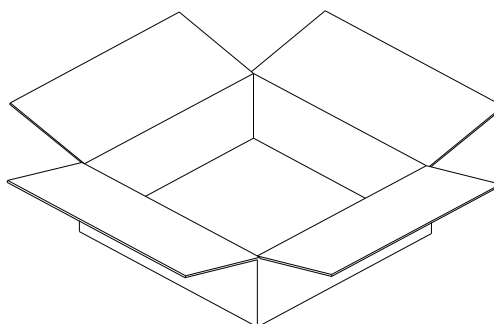

Outer carton

4. Packing.

- To pack the carton by scotch tape and affix out-going label (outside) on it outside.
- The Inspection data in the box , there would be a signet mark on it outside.

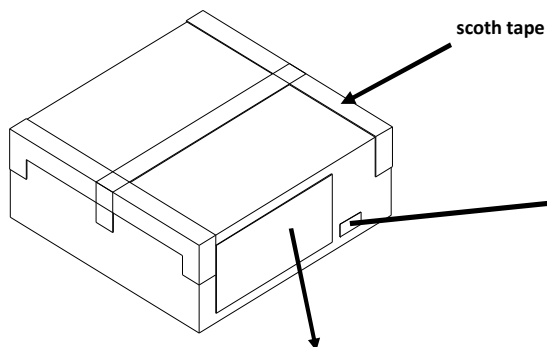

INSPECTION DATA
ENCLOSED
檢驗紀錄表在內

signet mark of Inspection data

(3S) TTW-WL11K0600200101400000360 		CUSTOMER: Customer	
(6S) C/NO:1		BOX COUNT	CUST. PART NO(P): 12A34567-89A
		001/009	
SHIPPING MARK		ROHS	TDK ITEM CODE(6P): TTXDF12345TWN
SAMPLE		P/O NO.(K): TTTT-S123456789	
		LOT NO.(IT): WL12345678	DATE: Nov.22.2011
		QTY(Q): 288	
Customer		TDK ITEM (IP): WT-1005660-12K2-A6-G	
Location			
MADE IN TAIWAN		(WT-1005660-12K2-A6-G)	
WL12K34567		SUB P/O NO.(6K): 4500059424	
12345A6789			
		TDK SPEC.	
C/NO : 1	WAREHOUSE	(CT)	9
	NW 3.6	GW 4.0	TTXDF10105

out-going label (outside)