

REVISIONS					
REV	DATE	DESCRIPTION	BY	CHK	APP'D
E4	03AUG2022	REVISED PER ECR-21-117154	SKR	VS	

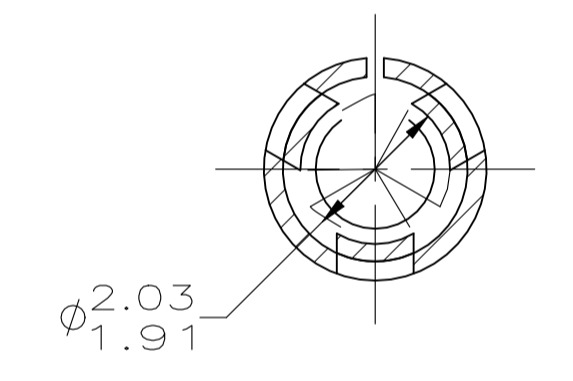

SECTION A-A
SCALE 10:1

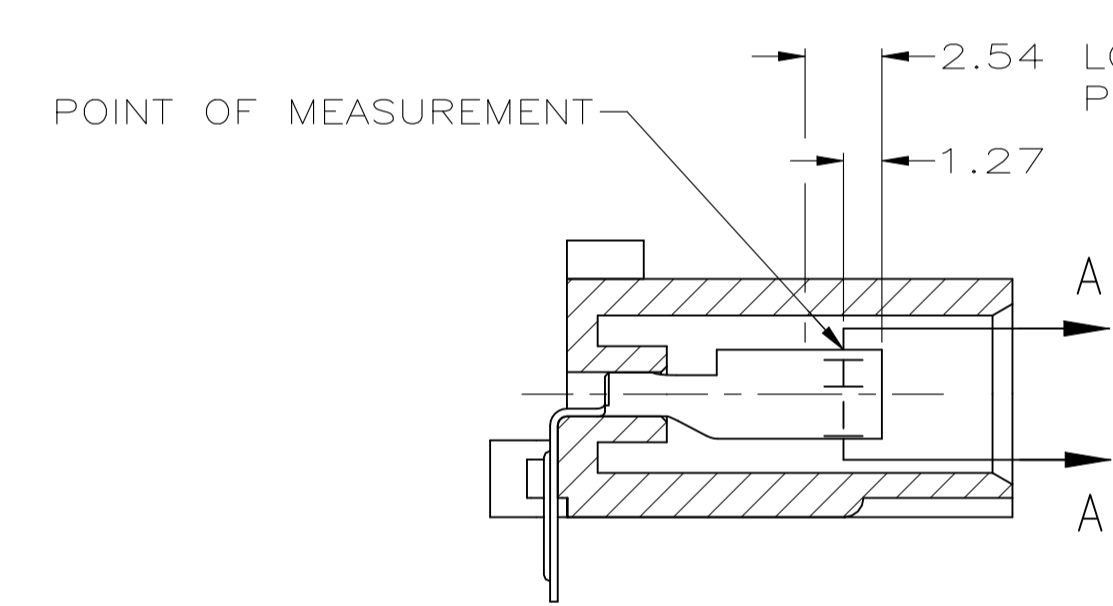
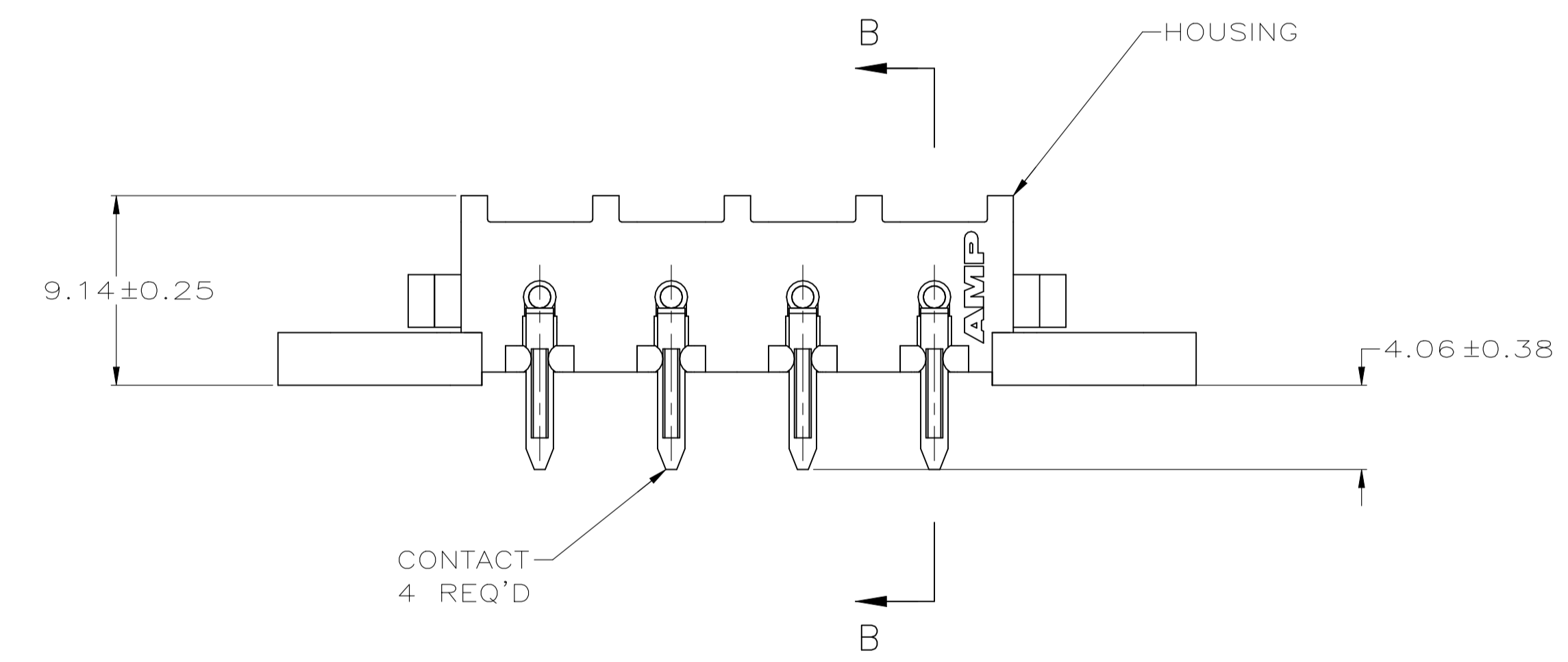
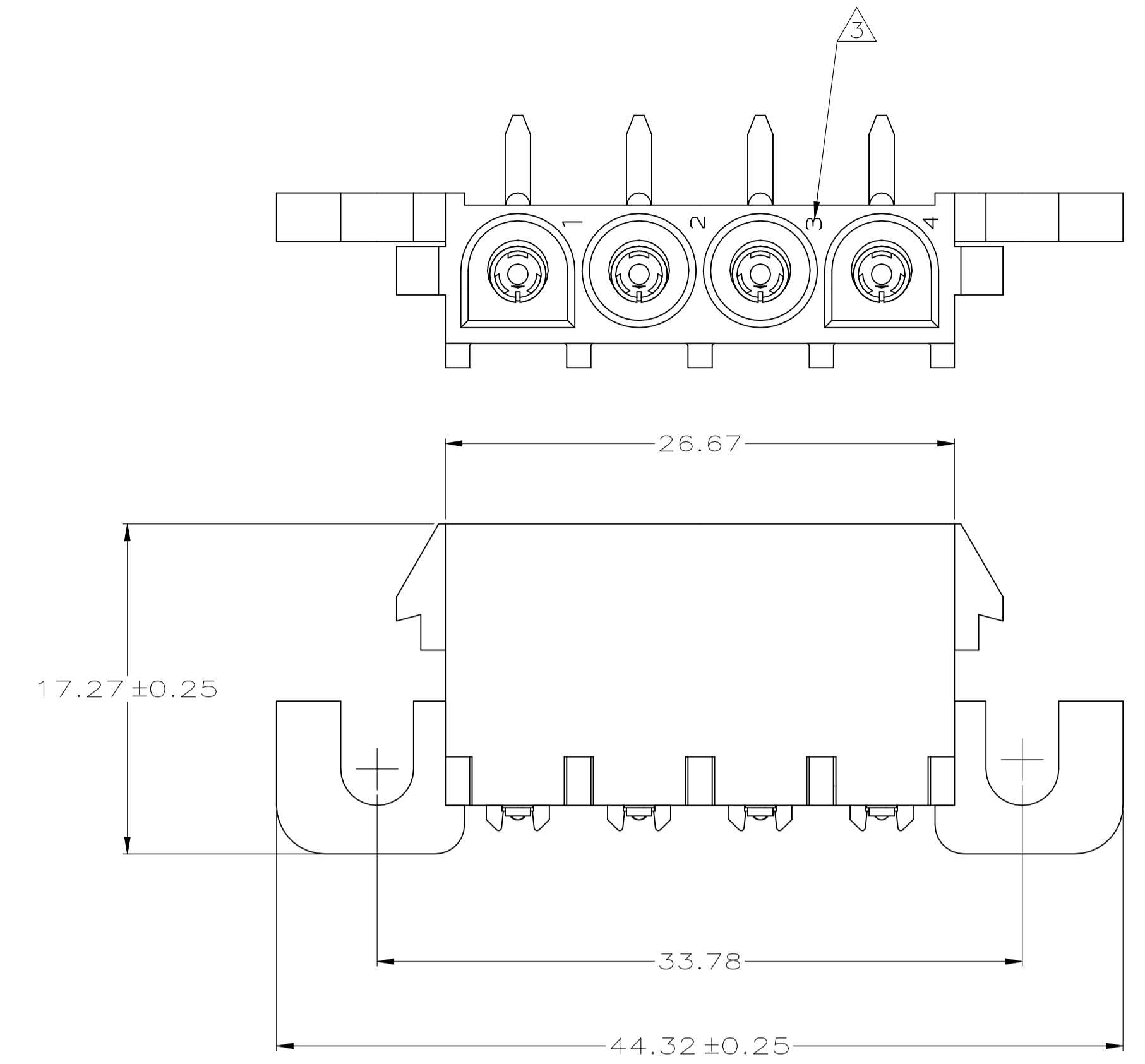
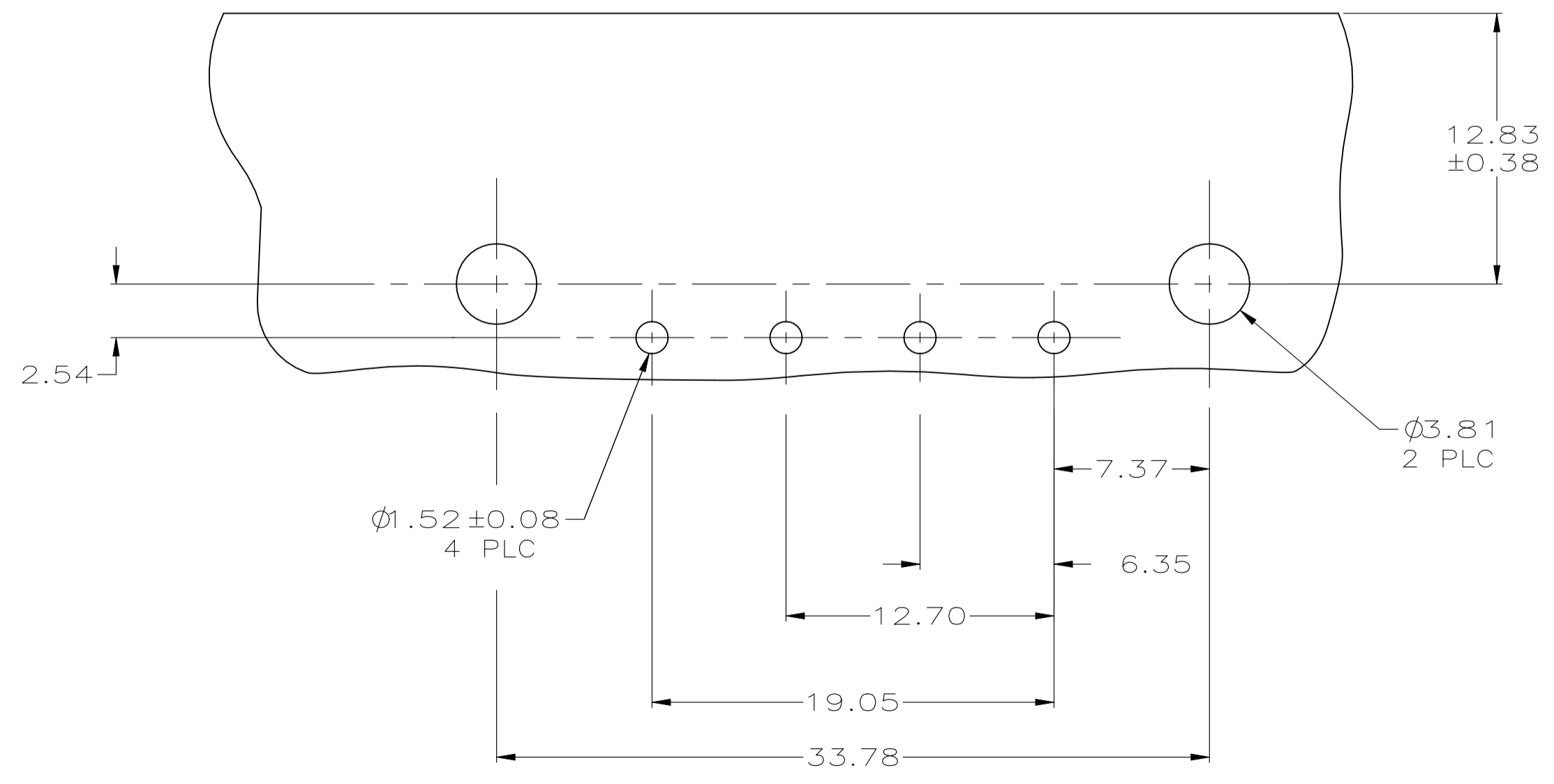

RECOMMENDED MOUNTING HOLE PATTERN FOR 1.57 THICK P.C. BOARD

- 1 PARTS COMPLY WITH AMP SOLDERABILITY SPECIFICATION 109-11-5.
- 2 0.00076 GOLD OVER 0.00127 MIN NICKEL WITH MATTE TIN LEAD ON SOLDER TAIL.
- 3 CIRCUIT IDENTIFICATION CHARACTERS ARE ADJACENT TO THE INDICATED CAVITIES, BUT LOCATION AND ORIENTATION MAY DIFFER FROM PRINT.
- 4 0.00076 GOLD OVER 0.00127 MIN NICKEL WITH MATTE TIN ON SOLDER TAIL.
- 5 SUPERSEDED BY 3-643230-0
- 6 DIMENSIONS SHOWN REPRESENT PRODUCT IN DRY CONDITION. ADDITIONAL 2% GROWTH DUE TO END USE LOCATION MOISTURE ABSORPTION MAY OCCUR AND SHOULD BE ACCOUNTED FOR

MM	IN	MM	IN
3.81	.150		
2.54	.100		
2.03	.080	44.32	1.745
1.91	.075	33.78	1.330
1.57	.062	26.67	1.050
1.52	.060	19.05	.750
1.27	.050	17.27	.680
0.38	.015	12.83	.505
0.25	.010	12.70	.500
0.13	.005	9.14	.360
0.08	.003	7.37	.290
0.00127	.000050	6.35	.250
0.00076	.000030	4.06	.160
MM	IN	MM	IN

CONVERSION TABLE

PH BRZ, $\triangle 4$	NYLON UL 94V-0	3-643230-0
PH BRZ, $\triangle 2$	NYLON UL 94V-0	643230-2
PH BRZ, TIN	NYLON UL 94V-0	643230-1
CONTACT	HOUSING	PART NUMBER

THIS DRAWING IS A CONTROLLED DOCUMENT.

DIMENSIONS: mm	TOLERANCES UNLESS OTHERWISE SPECIFIED:	DIN K. WHITAKER 21APR2005	TE Connectivity Ltd.
0 PLC ± -	1 PLC ± -	CHK S. RIDGILL 21APR2005	NAME
2 PLC ± 0.13	3 PLC ± -	APPROV S. RIDGILL 21APR2005	PRODUCT SPEC
4 PLC ± -	ANGLES ± -	APPLICATION SPEC	SIZE
MATERIAL SEE TABLE	FINISH SEE TABLE	WEIGHT 0.000000	SCALE 4:1
CUSTOMER DRAWING		DRAWING NO. A100779	SHEET 1 of 1
		REV E4	REV E4