

## Silicon Standard Recovery Diode

$V_{RRM} = 100\text{ V} - 600\text{ V}$

$I_F = 300\text{ A}$

### Features

- High Surge Capability
- Types up to 600 V  $V_{RRM}$
- Not ESD Sensitive

DO-9 Package

### Note:

1. Standard polarity: Stud is cathode.
2. Reverse polarity (R): Stud is anode.
3. Stud is base.

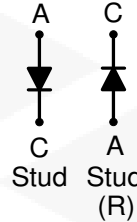

### Maximum ratings, at $T_j = 25\text{ }^\circ\text{C}$ , unless otherwise specified ("R" devices have leads reversed)

Parameter	Symbol	Conditions	S300B (R)	S300D (R)	S300E (R)	S300G (R)	S300J (R)	Unit
Repetitive peak reverse voltage	$V_{RRM}$		100	200	300	400	600	V
RMS reverse voltage	$V_{RMS}$		70	140	212	280	420	V
DC blocking voltage	$V_{DC}$		100	200	300	400	600	V
Continuous forward current	$I_F$	$T_C \leq 130\text{ }^\circ\text{C}$	300	300	300	300	300	A
Surge non-repetitive forward current, Half Sine Wave	$I_{F,SM}$	$T_C = 25\text{ }^\circ\text{C}$ , $t_p = 8.3\text{ ms}$	6850	6850	6850	6850	6850	A
Operating temperature	$T_j$		-55 to 150	-55 to 150	-55 to 150	-55 to 150	-55 to 150	$^\circ\text{C}$
Storage temperature	$T_{stg}$		-55 to 150	-55 to 150	-55 to 150	-55 to 150	-55 to 150	$^\circ\text{C}$

### Electrical characteristics, at $T_j = 25\text{ }^\circ\text{C}$ , unless otherwise specified

Parameter	Symbol	Conditions	S300B (R)	S300D (R)	S300E (R)	S300G (R)	S300J (R)	Unit
Diode forward voltage	$V_F$	$I_F = 300\text{ A}$ , $T_j = 25\text{ }^\circ\text{C}$	1.2	1.2	1.2	1.2	1.2	V
Reverse current	$I_R$	$V_R = 100\text{ V}$ , $T_j = 25\text{ }^\circ\text{C}$	10	10	10	10	10	$\mu\text{A}$
		$V_R = 100\text{ V}$ , $T_j = 175\text{ }^\circ\text{C}$	12	12	12	12	12	mA

### Thermal characteristics

Parameter	Symbol	Conditions	S300B (R)	S300D (R)	S300E (R)	S300G (R)	S300J (R)	Unit
Thermal resistance, junction - case	$R_{thJC}$		0.16	0.16	0.16	0.16	0.16	$^\circ\text{C/W}$

Figure.1-Typical Forward Characteristics

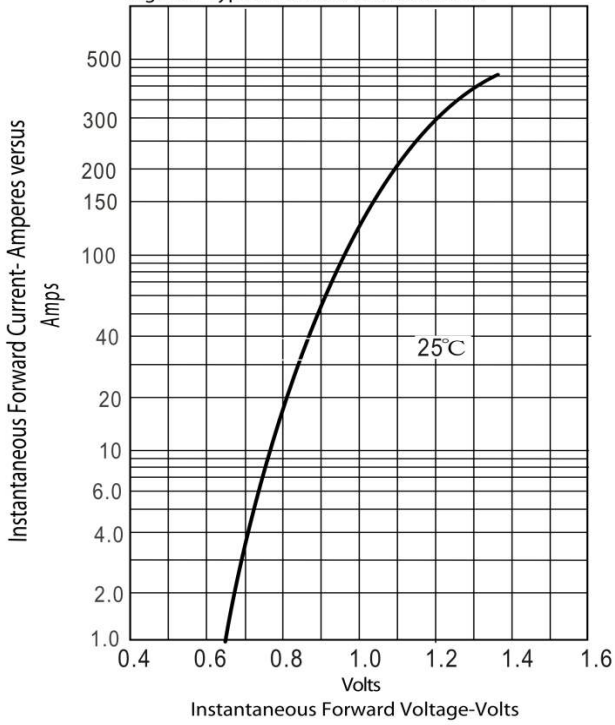

Figur.2-Forward Derating Curve

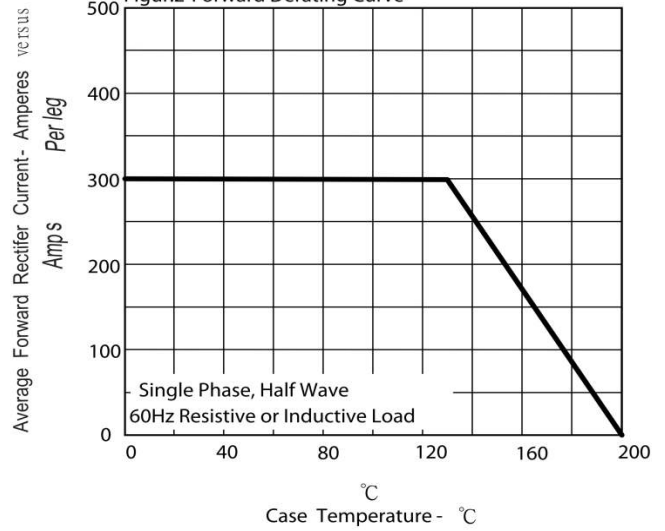
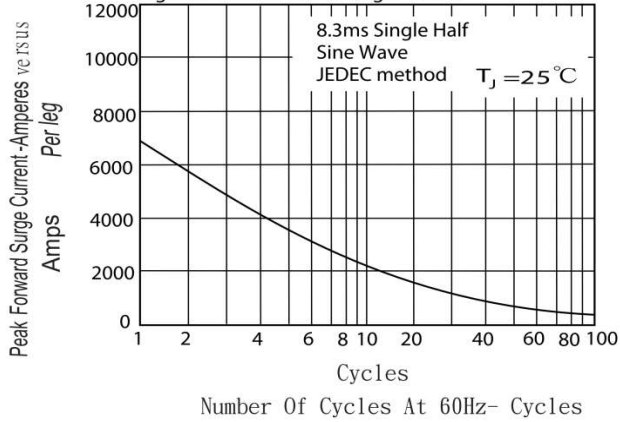
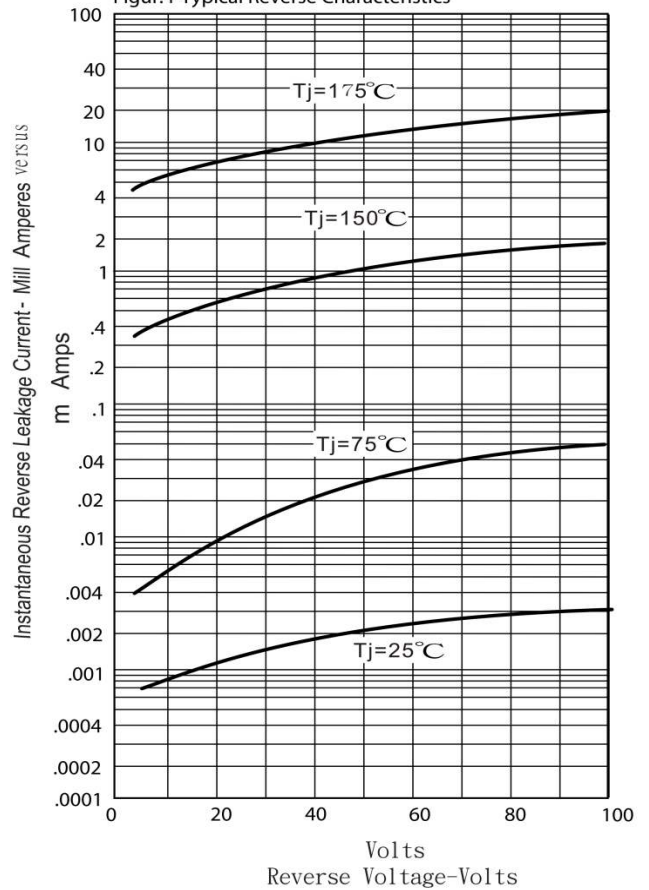

Figure.3-Peak Forward Surge Current



Figur.4-Typical Reverse Characteristics



**Package dimensions and terminal configuration**

Product is marked with part number and terminal configuration.

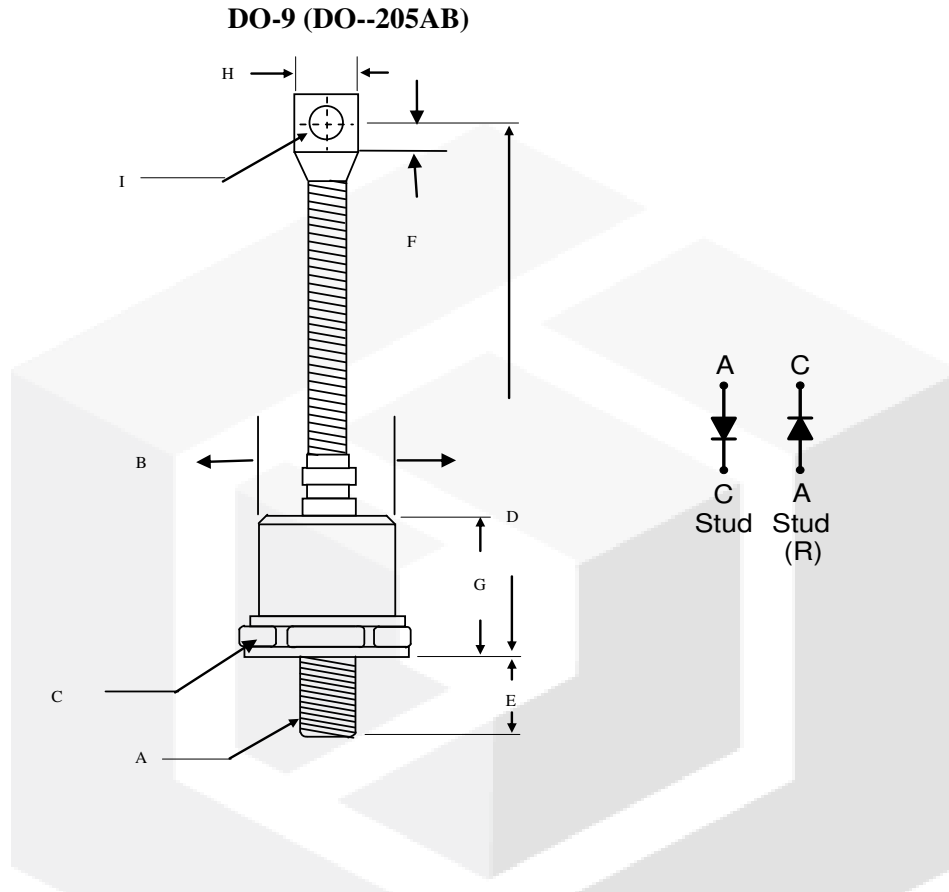

	Inches		Millimeters	
	Min	Max	Min	Max
A	3/4 - 16 UNF			
B	-----	1.10	-----	27.94
C	1.24	1.25	31.5	31.90
D	-----	7.48	-----	190.0
E	0.78	0.828	19.60	21.03
F	0.470	0.530	11.94	13.46
G	-----	1.122	-----	28.5
H	-----	0.787	-----	20.0
I	0.330	0.350	8.38	8.89