

THIS DRAWING IS UNPUBLISHED.

RELEASED FOR PUBLICATION

ALL RIGHTS RESERVED.

© COPYRIGHT - By -

REVISIONS

P	LTR	DESCRIPTION	DATE	DWN	APVD
	B3	PART 1437648-2 STATUS CORRECTED	20FEB2019	RK	PS

MATERIALS:
 HOUSING: POLYAMIDE, UL94V-0.
 TERMINALS: COPPER ALLOY, TIN PLATED.
 SCREWS: STEEL, ZINC PLATED. (UNLESS OTHERWISE NOTED)

ELECTRICAL:
 RATING: 20A, 150V (300V LIMITED RATING)
 UL & CSA

MECHANICAL:
 WIRE RANGE: 14 - 22 AWG
 MAXIMUM TIGHTENING TORQUE: 7 IN-LBS.
 RUNNING TORQUE: 0.5 - 3.5 IN-LBS.

▲ TERMINALS: COPPER ALLOY, NICKEL PLATED

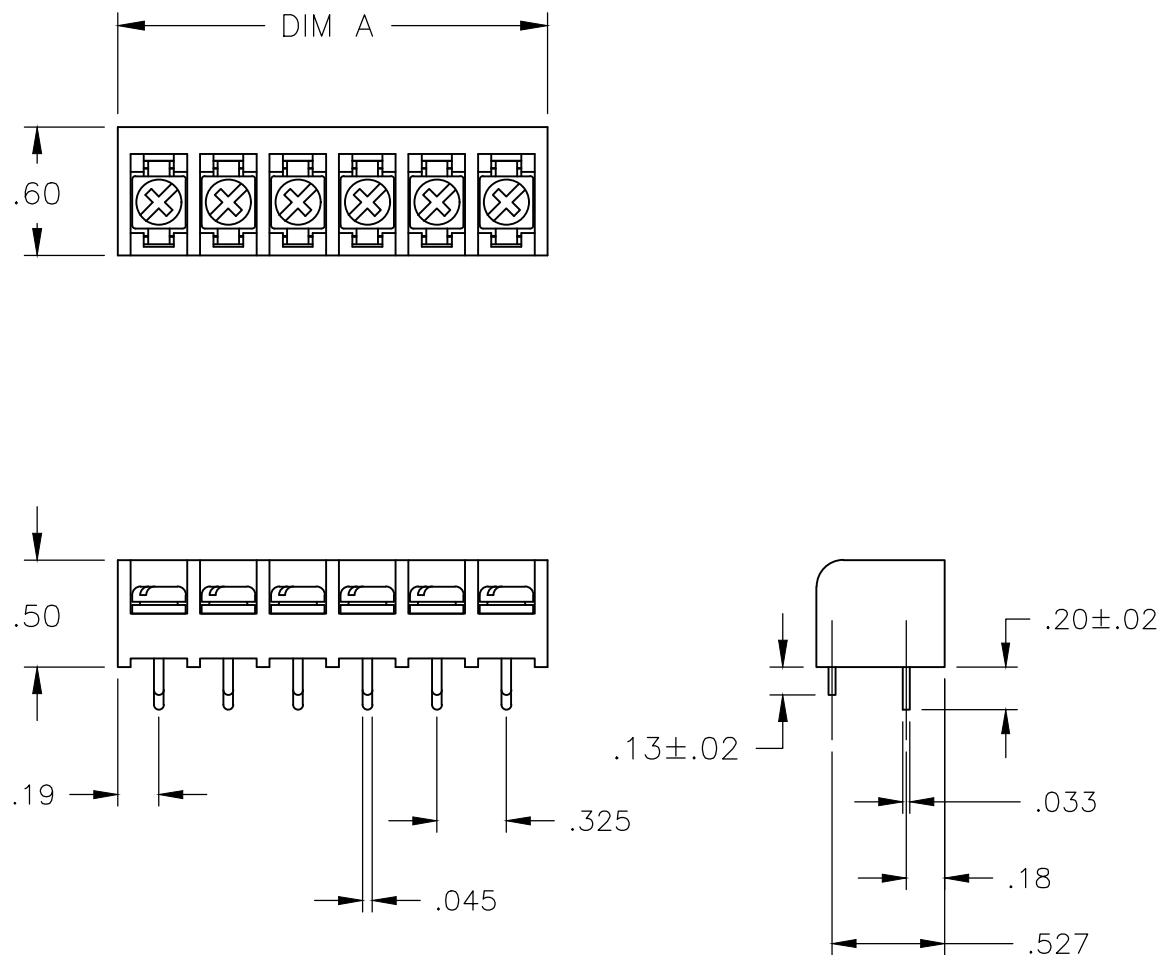

9.811	30	4DBL-30-006	2-1546937-5
9.486	29	4DBL-29-006	2-1546937-4
9.161	28	4DBL-28-006	2-1546937-3
8.836	27	4DBL-27-006	2-1546937-2
8.511	26	4DBL-26-006	2-1546937-1
8.186	25	4DBL-25-006	2-1546937-0
7.861	24	4DBL-24-006	1-1546937-9
7.536	23	4DBL-23-006	1-1546937-8
7.211	22	4DBL-22-006	1-1546937-7
6.886	21	4DBL-21-006	1-1546937-6
6.561	20	4DBL-20-006	1-1546937-5
6.236	19	4DBL-19-006	1-1546937-4
5.911	18	4DBL-18-006	1-1546937-3
5.586	17	4DBL-17-006	1-1546937-2
5.261	16	4DBL-16-006	1-1546937-1
4.936	15	4DBL-15-006	1-1546937-0
4.611	14	4DBL-14-006	1546937-9
4.286	13	4DBL-13-006	1546937-8
3.961	12	4DBL-12-006	1437648-7
3.636	11	4DBL-11-006	1546937-7
3.311	10	4DBL-10-006	1546937-6
2.986	9	4DBL-09-006	1546937-5
2.661	8	4DBL-08-006	1546937-4
2.336	7	4DBL-07-006	1546937-3
2.011	6	4DBL-06-006	1546937-2
1.686	5	4DBL-05-006	1546937-1
1.361	4	4DBL-04-006	1437648-5
1.036	3	4DBL-03-006	1437648-3
.711	2	-	2-1546937-6
.711	2	4DBL-02-006	1437648-2
DIM. A	NO OF POS	CATALOG NUMBER	PART NUMBER

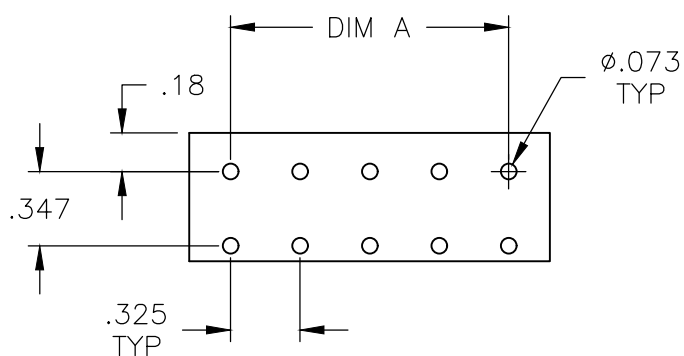

RECOMMENDED HOLE LAYOUT
 TOLERANCE $\pm.002$, UNLESS OTHERWISE SPECIFIED

THIS DRAWING IS A CONTROLLED DOCUMENT.		DWN S SCHLEGEL 6/19/07	STE TE Connectivity	
DIMENSIONS: INCHES		CHK S YODER 6/19/07		
TOLERANCES UNLESS OTHERWISE SPECIFIED:		APVD S YODER 6/19/07	NAME	
0 PLC $\pm -$	1 PLC $\pm -$	PRODUCT SPEC	4DBL-XX-006 ASSEMBLY	
2 PLC $\pm .02$	3 PLC $\pm .008$	APPLICATION SPEC	SIZE	CAGE CODE
4 PLC $\pm -$	ANGLES $\pm 2'$	FINISH	RESTRICTED TO	DRAWING NO
MATERIAL -	FINISH -	WEIGHT -	A3	00779
CUSTOMER DRAWING			SCALE NTS	SHEET 1 OF 1
			DWG NO C-1437648-2	REV B3