

Transfer or duplication of this document as well as the utilisation or communication of its content are not permitted unless express consent is granted. Violations give rise to claims for damages. All rights reserved in case of patent, utility model or design patent registrations.

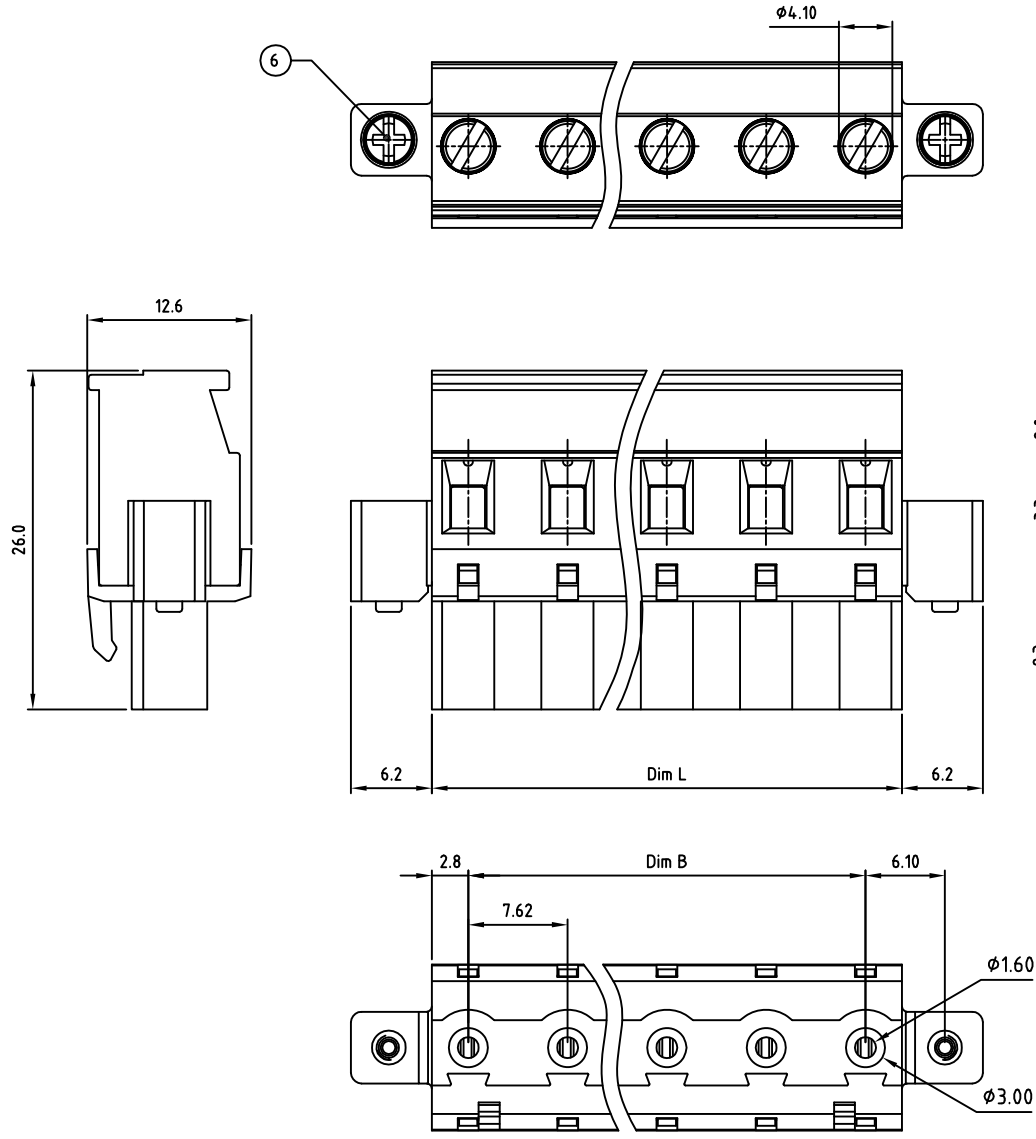

**Technical data**

- 1.Nominal voltage: 300V/15A  
PITCH:7.62mm
- 2.Connection capacity:  
AWG 30-12
- 3.Insulation Withstanding Voltage:  
AC 1600V/MIN
- 4.Insulation Resistance:  
1000MΩ or more at DC500V
- 5.Tightening torque:  
5.0kgf.cm (0.5N.m)
- 6.Screw thread: M3
- 7.Stripping length: 6-7mm
- 8.Operating temperature range:-40°C ~ 115°C
- 9.Undimensioned Tolerances:

Dim.L=(P-1)x7.62+5.6		
Dim.B=(P-1)x7.62		
P= number of poles		
0-30mm	Dim B	Dim L
over 30mm-60mm	±0.15	±0.20
over 60mm-90mm	±0.20	±0.25
over 90mm	±0.25	±0.30
	±0.30	±0.40

- 10.Safety approval:
  - 11.RoHS Compliance
- Part No.: **OSTTSXX015D**
- |              |                     |
|--------------|---------------------|
| No. of Poles | COLOR               |
| 02 2 Poles   | 0: Black            |
| 03 3 Poles   | 2: Red              |
| ...          | 3: Orange           |
| 24 24 Poles  | 4: Yellow           |
|              | 5: Green (Standard) |
|              | 6: Blue             |
|              | 8: Grey             |
- Nonstandard colors  
Mins could apply

6	FLANGE SCREW	STEEL	M2.5, Zn Plated	2
5	CAGE	BRASS	M3, Ni Plated	P
4	SCREW	STEEL	M3, Zn Plated	P
3	WIRE GUARD	BRONZE (PhBz)	TIN PLATED	P
2	COVER	PA66 UL94V-0	ALL COLOR	1
1	BODY	PA66 UL94V-0	ALL COLOR	1

ITEM	NAME OF PART	MATERIAL	NOTES	Q'TY	
DWG	Marvin Zhang	DATE 2017.07.01	UNITS: MM	SHEET: 1 OF 1	Tolerance
CHK.	Marvin Zhang	DATE 2017.07.01	SCALE: NONE 2.5:1 ( : )	REV: B	X. ±0.50
APP.		DATE	TITLE: OSTTS 7.62 Series "-" slot		X.X ±0.30
			PART NO. OSTTSXX015D		X.XX ±1.0
			DWG NO. OSTTSXX015D.dwg		X* ±1°

SIGN	DESCRIPTION	CHK.	DATE	



ON-SHORE TECHNOLOGY, INC.