

Figure 1

1. INTRODUCTION

Pneumatic Head Assembly 679304-1 (shown in Figure 1) is designed to accept interchangeable die assemblies used in PRO-CRIMPER* hand tools for crimping various types of connectors. The head assembly is used in the 626 Pneumatic Tooling Assemblies 189721-1 and 189722-1.

This instruction sheet provides recommended procedures for die installation and removal, crimp head installation and removal, basic crimping procedures, and maintenance and inspection. For specific information concerning cable preparation and crimping procedures, refer to the instruction sheet packaged with the appropriate die set.

Reasons for reissue of this instruction sheet are provided in Section 6, REVISION SUMMARY.

2. INSTALLATION AND REMOVAL

2.1. Die Assembly

Remove the head assembly from the tool holder assembly; then remove the two pan head screws and bushings from the jaws of the head assembly.

Install the appropriate die assembly according to the following:

A. Shouldered Dies (See Figure 2)

1. Open the jaws of the head assembly by squeezing the rollers together. Place the anvil die into the jaw.
2. Slide the bushing over the pan head screw and insert the pan head screw through the head assembly jaw and anvil die. Tighten the screw just enough to hold the die in place.

NOTE



The die assembly shown in Figure 2 has center contact crimping chambers and is installed with the crimping chambers positioned toward the front of the head assembly. If shown otherwise in other instruction sheets, follow the die installation requirements for the specific application.

3. Place the crimper die into the jaw of the head assembly as shown in Figure 2.
4. Slide bushing over pan head screw and insert pan head screw through the head assembly jaw and crimper die. Tighten screw just enough to hold the die in place.

Installing Shouldered Dies

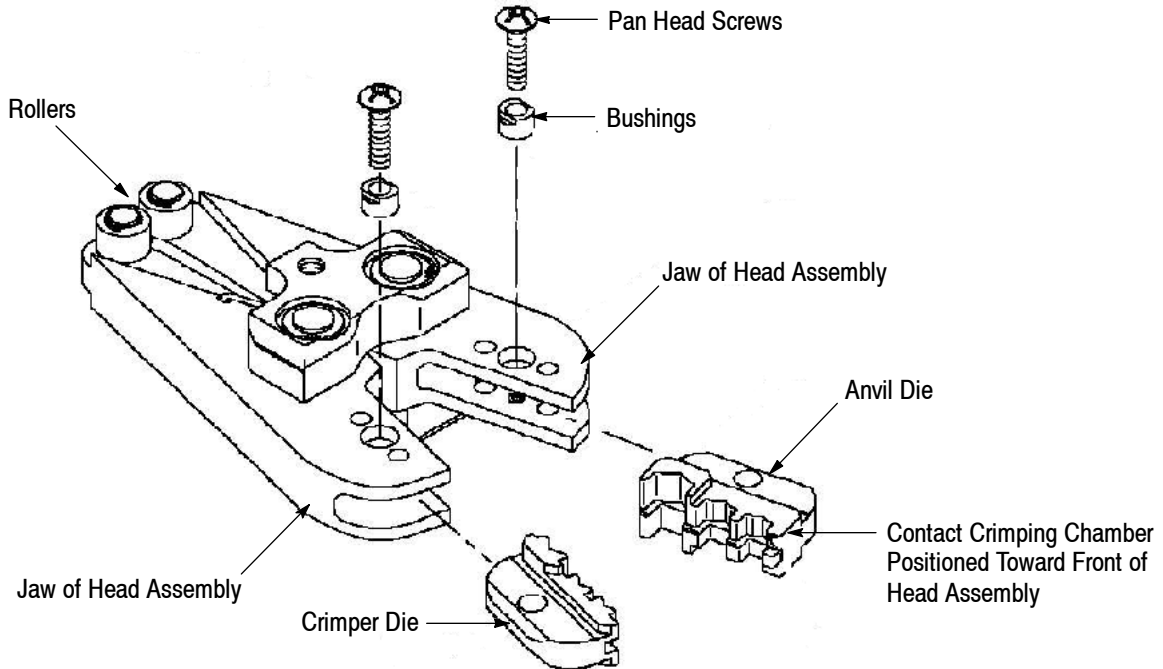

Figure 2

5. Check the die alignment by allowing the jaws to spring shut. If the dies are properly aligned, tighten the die retaining screws.
6. To remove the dies from the head assembly, loosen the pan head screws and slide the dies out of the jaws.

6. Install the locator assembly onto the long retaining screw and secure it with the hex nut.
7. To remove the dies from the jaws, loosen the die retaining screws and slide the dies out of the jaws.

B. Pinned Dies (See Figure 3)

1. Open the jaws of the head assembly by squeezing the rollers together. Install the anvil die into the jaw. The die should be oriented so that the chamfers are positioned toward the front of the head assembly and the die markings are facing outward.
2. Insert the bushing into the jaw. Insert the two die retaining pins and the *short* die retaining screw into the jaw and through the anvil die. Tighten the screw just enough to hold the die in place.
3. Install the crimper die into the jaw as shown in Figure 3. The die should be oriented so that the chamfers are positioned toward the front of the head assembly and the die markings are facing outward.
4. Insert the bushing into the jaw. Insert the two die retaining pins and the *long* die retaining screw into the jaw and through the crimper die. Tighten the retaining screw just enough to hold the die in place.
5. Check the die alignment by allowing the jaws to spring shut. If the dies are properly aligned, tighten the die retaining screws.

2.2. Head Assembly



TO AVOID PERSONAL INJURY, disconnect the pneumatic tooling assembly from the air supply before installing or removing the head assembly.

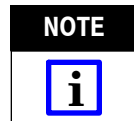

Certain precautions should be taken by the operator to avoid personal injury or damage to the pneumatic tool. Refer to the instruction sheet supplied with the pneumatic tool for operation and safety precautions.

1. Insert the head assembly into the tool holder assembly of the pneumatic tooling assembly as shown in Figure 1.
2. After the head assembly is properly aligned, insert and tighten the quick pins provided with the pneumatic tooling assembly. Refer to Figure 1.

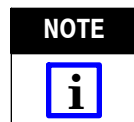

It is recommended using Loctite 242 removable threadlocker or equivalent to prevent the quick pins from loosening.

Loctite is a trademark of Henkel Corporation.

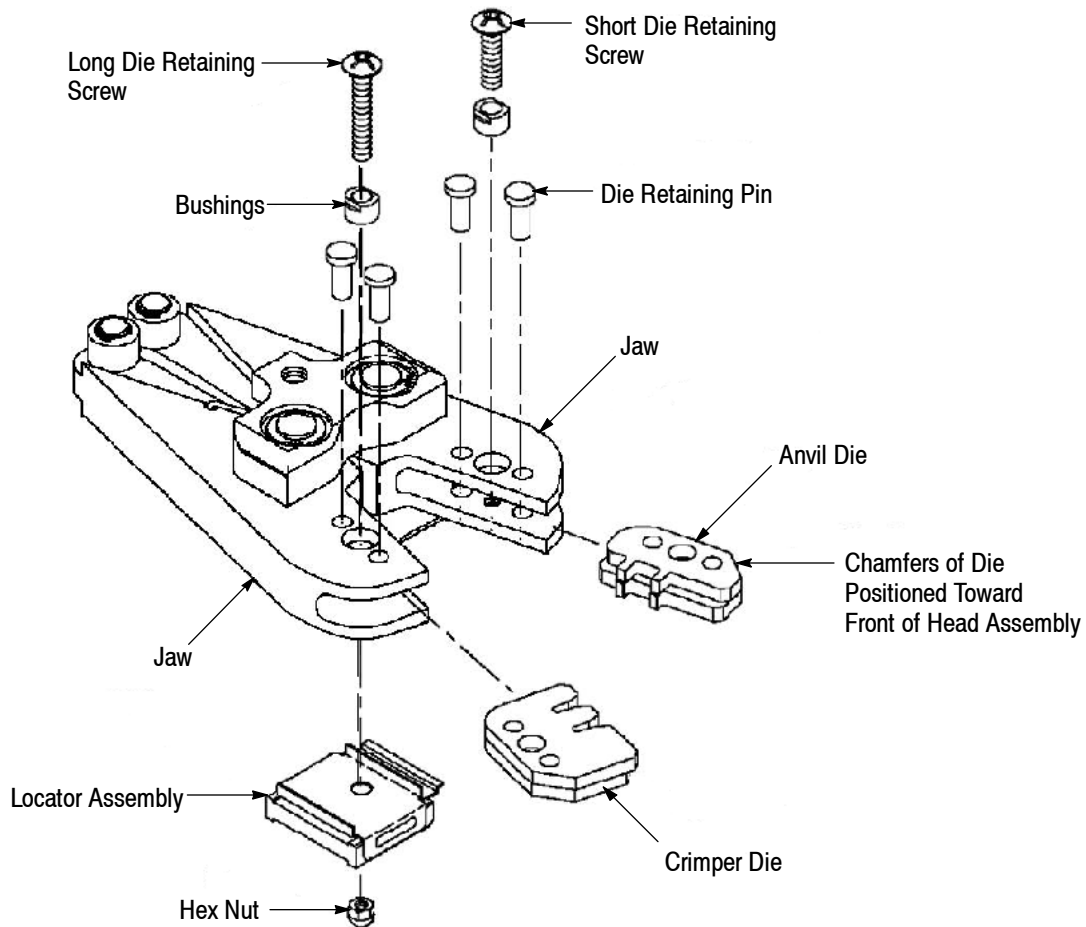

Figure 3

3. Connect the tool to an adequate air supply (between 620 and 690 kPa [90 and 100 psi]). For specific information on air line requirements and air hose installation, refer to the instructions packaged with the pneumatic tooling assembly.

4. To remove the head assembly from the tool holder, remove quick pins, then remove the head assembly from tool holder.

3. CRIMPING PROCEDURE

The crimping procedures which follow are basic. Refer to the instruction sheet packaged with the die assembly for details.

DANGER ALWAYS keep fingers clear of head assembly jaws when operating the pneumatic tooling assembly.

1. Strip the wire using the recommended strip length dimensions. Refer to instruction sheet supplied with the die assembly.

2. Open the jaws of the head assembly by squeezing the rollers together; then position the connector into the appropriate crimping chamber.

3. After the connector is properly positioned in the dies, release the rollers to allow the jaws to spring shut, securing the connector within the dies.

4. Insert the stripped wire into the connector.

5. Activate the pneumatic tooling assembly to complete the crimp. Open the jaws by squeezing the rollers together, then remove the crimped connector.

4. MAINTENANCE AND INSPECTION

DANGER ALWAYS disconnect the pneumatic tooling assembly from the air supply before performing any maintenance or inspection.

The head assembly is thoroughly inspected before packaging. Since there is the possibility of damage during shipment, new head assemblies should be inspected immediately upon arrival at your facility.

A maintenance and inspection program should be performed periodically to ensure dependable and uniform terminations. The head assembly should be inspected once a month. Frequency of inspection should be adjusted to suit your requirements through experience. Frequency of inspection depends on:

1. The care, amount of use, and handling of the head.
2. The type and size of the product crimped.
3. The degree of operator skill.
4. The presence of abnormal amounts of dust and dirt.
5. Your own established standards.

NOTE

For die closure inspections and plug gage dimensions, refer to the instruction sheet supplied with the appropriate die assembly.

4.1. Cleaning

Remove dust, moisture, and other contaminants with a clean, soft brush, or a soft, lint-free cloth. DO NOT use objects or cleaning materials that could damage the head assembly. Re-lubricate the head assembly as instructed in Paragraph 4.3 before placing it back into service.

4.2. Visual Inspection

1. Inspect the head assembly for missing pins and retaining rings. If parts are missing or defective, replace them by referring to Section 5.
2. Check all bearing surfaces for wear. Make sure the rollers turn freely with minimal resistance. Replace any worn parts.
3. Inspect the crimping areas of the die assembly for flattened, chipped, or broken areas. Although the dies may gage within permissible limits, worn or damaged die closure surfaces may affect the quality of the crimp.

4.3. Lubrication

Lubricate all pins, pivot points, and bearing surfaces with a high quality grease. Use Dow Corning Molykote paste, which is a commercially available lubricant. Lubricate according to the following schedule:

- Head used in daily production — lubricate daily
- Head used daily (occasional) — lubricate weekly
- Head used weekly — lubricate monthly

Wipe excess grease from the head assembly, particularly in the die closure areas. Grease transferred from the die closure area onto certain terminations may affect the electrical characteristics of a termination.

5. REPLACEMENT AND REPAIR

Replacement parts and recommended spares are listed in Figure 4. The recommended spares should be stocked for immediate replacement. Order replacement parts through your Representative, or call 1-800-526-5142, or send a facsimile of your purchase order to 1-717-986-7605, or write to:

CUSTOMER SERVICE (38-35)
TYCO ELECTRONICS CORPORATION
PO BOX 3608
HARRISBURG PA 17105-3608

For customer repair service, call 1-800-526-5136.

6. REVISION SUMMARY

Revisions to this instruction sheet include:

- Added "Original Instructions" to page 1

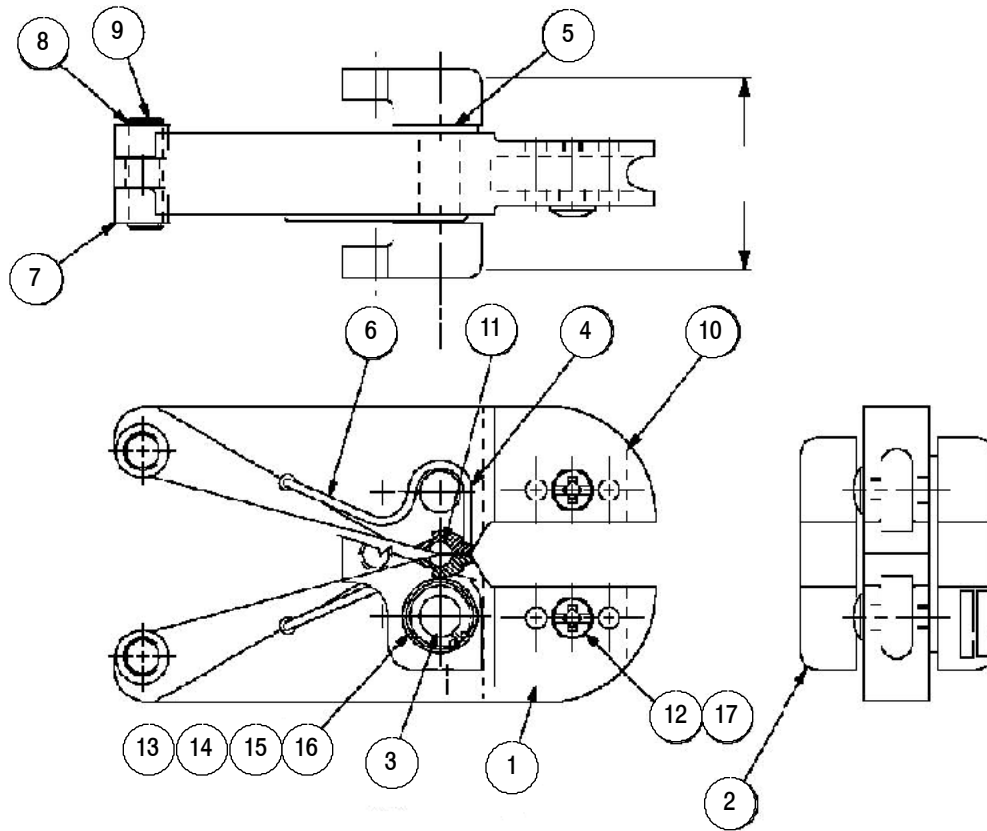

CUSTOMER REPLACEABLE PARTS

ITEM	PART NUMBER	DESCRIPTION	QTY PER ASSEMBLY
1	679192-1	ARM, Crimper	1
2	768521-3	LINK	2
3	6-23629-0	PIN, Straight Groove	2
4	1-21048-0	RING, Retaining	4
5	314655-3	SHIM	1
6●	679942-1	SPRING	1
7●	314479-2	ROLLER, Cam	4
8●	21045-6	RING, Retaining	4
9●	3-23620-3	PIN, Straight Groove	2
10	679192-2	ARM, Crimper	1
11	23241-2	BALL, Steel	1
12	986964-4	SCREW, Pan Head	2
13	301185-6	SHIM	<i>As Required</i>
14	301185-7	SHIM	<i>As Required</i>
15	301185-8	SHIM	<i>As Required</i>
16	301185-9	SHIM	<i>As Required</i>
17	1213501-1	BUSHING	2

● Recommended Spare Part

Figure 4