

PART NUMBER	REV	FIRST USED
466643-1	5	122500-1
466643-2	5	565435-5

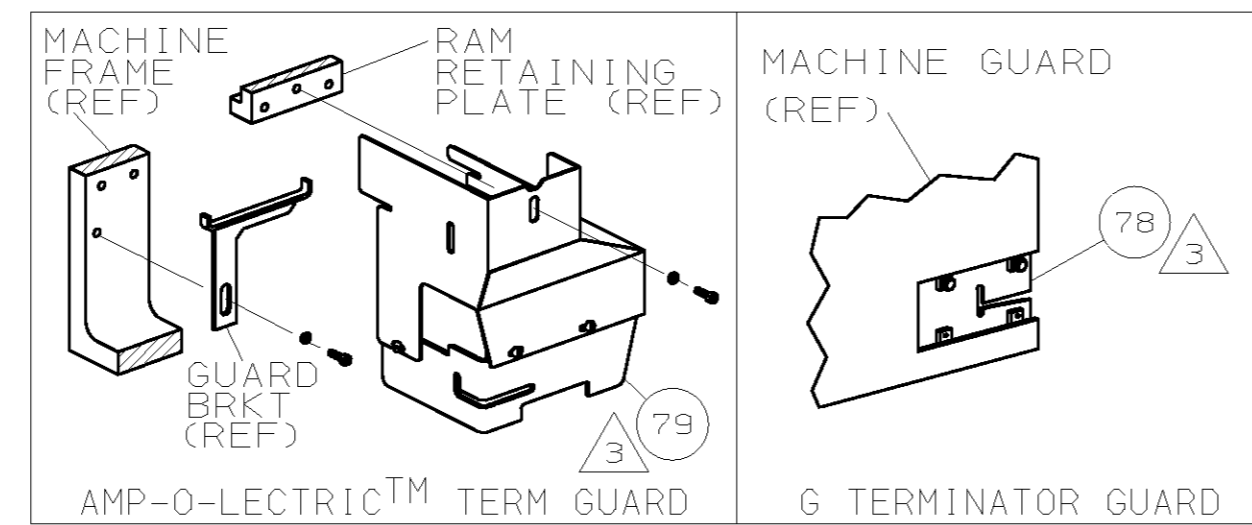

TERMINAL NAME: Ø.180 PLUG RECEPTACLE					
PAD LTR	CRIMP HEIGHT		WIRE SIZE		
	A	.109 ±.002 [2.77 ±0.05mm]	10		
B	.090 ±.002 [2.29 ±0.05mm]	12			
C	.078 ±.002 [1.98 ±0.05mm]	14			
D	.068 ±.002 [1.73 ±0.05mm]	16			
CRIMP	SIZE	TYPE	RANGE		
WIRE	.130 [3.3mm]	F	14-10		
INSUL	-	-	-		
WIRE STRIP LENGTH	TERM APPL SPEC	FEED	APPL INSTRUCTION	SET UP GAGE	LAYOUT
.204-.234	114-2017	.895	408-8039	458638-1	932

-1		LEADMAKER & BENCH MODEL G	MECH POST FEED			
-2		BENCH MODEL K	MECH POST FEED			
1	1	-	A	22594-8	NUT, HEX	70
1	1	-	B	240628-1	PLATE, ADJ	69
1	1	-	B	240626-1	SHAFT, PIVOT	68
1	1	-	B	240633-1	BUSHING	67
1	1	-	A	455680-1	LEVER, INTERMEDIATE	66
1	1	-	B	240629-1	BLOCK, PIVOT	65
1	1	-	A	240632-2	SCR, ADJ	64
1	1	-	B	240659-3	PIN, CAM ROLLER	63
1	1	-	B	240658-1	CAM, ROLLER	62
1	1	-	B	454398-1	ROD, FEED	61
						60
1	1	-	C	454220-1	CAP, RAM	59
1	1	-	D	453736-1	HOUSING	58
						57
						56
1	1	-	B	240624-1	PIN, FEED FINGER	55
1	1	-	B	691499-1	SPRING, FEED FINGER	54
1	1	-	B	240635-2	FINGER, FEED	53
1	1	-	B	240634-1	LEVER, TERMINAL	52
						51
						50
						49
1	-	-	B	690501-3	CAM, POST FEED 1 1/8 ST	48
-	1	-	B	690501-4	CAM, POST-FEED 1 5/8 ST	47
						46
1	1	-	A	690191-1	PLUG, NYLON	45
1	1	-	C	455674-1	RAM	44
1	1	-	A	690125-1	WASHER, LAMINATED	43
1	1	-	A	690124-1	WASHER, RAM	42
1	1	-	A	7-21002-9	BOLT, CRIMPER (5/16-24x1.00)	41
						40
						39
						38
1	1	-	A	690223-2	SPACER, INSULATION DISC	38
1	1	-	D	354777-1	WIRE DISC, PLASTIC	37
1	1	-	A	22480-5	WASHER, SPRING	36
1	1	-	B	690212-1	POST, RAM	35
						34
						33
						32
						31
						29
						28
1	1	-	A	690455-3	STRIPPER	27
1	1	-	C	455676-1	PLATE, BASE	26
2	2	-	A	22354-8	DRAG, STUD	25
1	1	-	B	455678-1	PLATE, STRIP GUIDE	24
1	1	-	C	240825-2	PLATE, STRIP HOLD DOWN	23
2	2	-	A	4-22281-1	SPRING, DRAG	22
						21
1	1	-	A	454177-1	DRAG, STOCK	20
						19
2	2	-	C	454204-4	GUIDE, STRIP (FRONT)	18
1	1	-	A	454178-1	GUIDE, FEED ROD	17
1	1	-	A	4-22284-9	SPRING, FEED RETURN	16
						15
						14
						13
						12
1	1	-	B	240644-1	PLATE, REAR SHEAR	11
2	2	-	C	1-240645-7	SPACER, SHEAR PLATE	10
1	1	-	B	240642-1	PLATE, FRONT SHEAR	9
1	1	-	D	3-240654-4	ANVIL	8
1	1	-	B	1-240651-0	BLADE, SLUG	7
						6
1	1	-	C	4-240641-5	SPACER, SLUG BLADE	5
						4
						3
						2
1	1	-	C	456410-7	CRIMPER, WIRE	1

THIS DRAWING IS A CONTROLLED DOCUMENT.

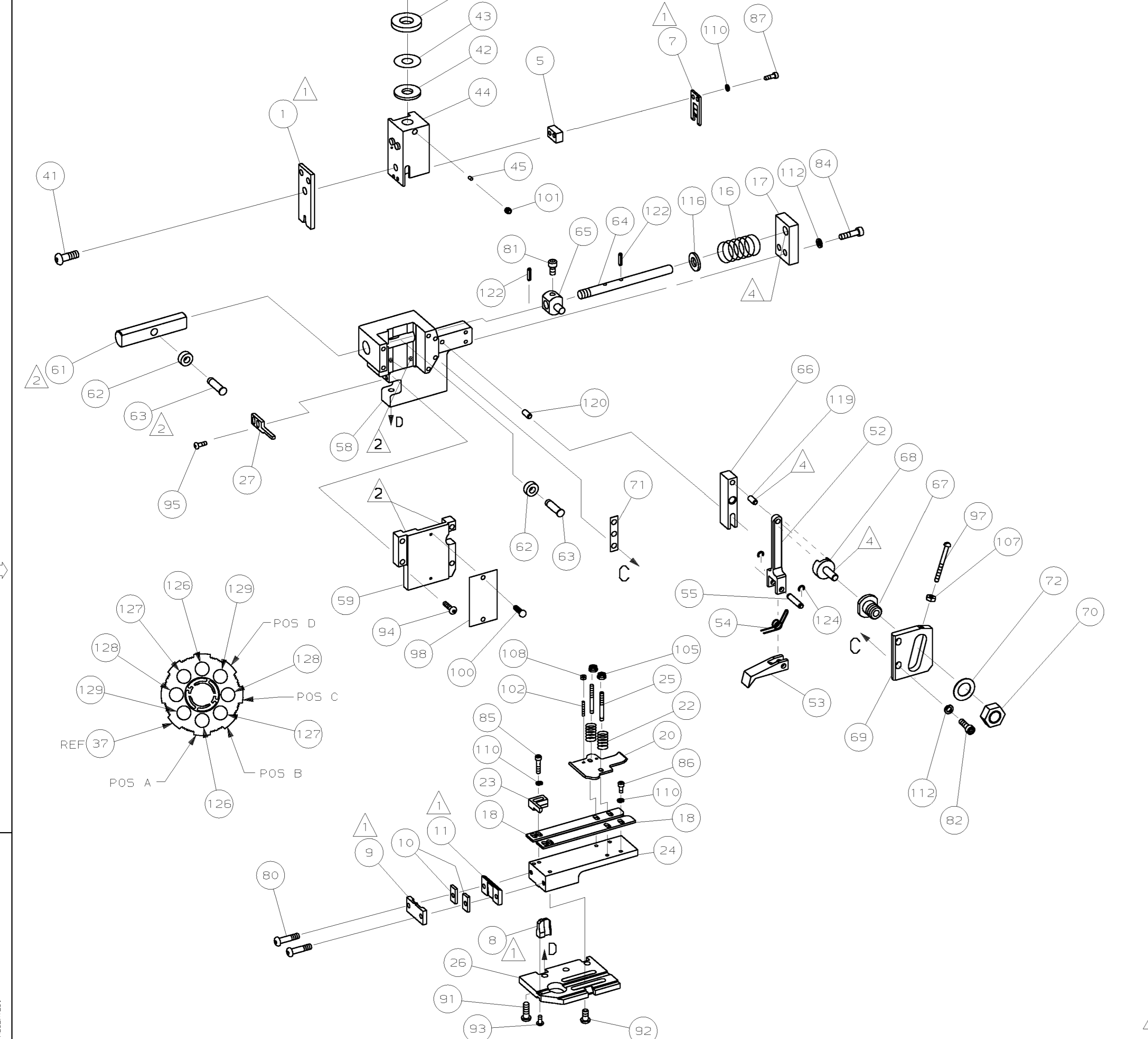

QTY	RECD PER ASSY	U/M	DWG SIZE	PART NO	DESCRIPTION	ITEM NO
2	2	-	C	1-354779-7	PIN, WIRE DISC (.3075)D	129
2	2	-	C	9-354778-2	PIN, WIRE DISC (.2955)C	128
2	2	-	C	6-354778-6	PIN, WIRE DISC (.2825)B	127
2	2	-	C	2-354778-5	PIN, WIRE DISC (.2620)A	126
1	1	-	A	986950-1	WASHER, FLAT PRECISION	125
2	2	-	A	21045-3	RING, RET "C" (Ø.187)FD PIN	124
						123
2	2	-	A	5-21028-1	PIN, STD SPRING (Ø.12)FD ADJ ROD	122
						121
1	1	-	A	1-21030-7	PIN, DOWEL (Ø.187x1.50)H5G	120
1	1	-	A	1-21030-1	PIN, DOWEL (Ø.187x.50)LEVER	119
						118
						117
1	1	-	A	21899-4	WASHER, FLAT (Ø5/16) SCR ADJ	116
						115
						114
						113
4	4	-	A	21024-5	WASHER, LOCK (NO.10)FD ROD GDE	112
						111
7	7	-	A	21024-4	WASHER, LOCK (NO.8)SHEAR BL	110
						109
2	2	-	A	21018-4	NUT, HEX (4-40)DRAG	108
1	1	-	A	21018-5	NUT, HEX (6-32)FD ADJ PL	107
						106
2	2	-	A	21022-2	NUT, HEX SL (8-32)DRAG STUD	105
						104
						103
2	2	-	A	2-21006-6	SCR, SKT SET (4-40x.62)DRAG	102
1	1	-	A	21009-2	SCR, SKT SET (1/4-20x.25)RAM	101
2	2	-	A	21017-2	SCR, DRIVE (#2x.19) ID PLATE	100
1	1	-	A	1-21002-7	SCR, BHC (6-32x.38)CAM	99
1	1	-	B	461264-1	PLATE, IDENTIFICATION	98
1	1	-	A	6-23715-5	SCR, PAN HD (6-32x1.50)FEED ADJ	97
						96
2	2	-	A	2-21002-2	SCR, BHC (8-32x.50)STRIPPER	95
4	4	-	A	2-21002-9	SCR, BHC (10-32x.75)H5G CAP	94
1	1	-	A	22733-8	SCR, BHC (8-32x.38 LW)ANVIL	93
4	4	-	A	3-21002-3	SCR, BHC (1/4-20x.50)ST 6D PL	92
3	3	-	A	2-22733-8	SCR, BHC (1/4-20x.62)BASE PL	91
						90
						89
						88
2	2	-	A	2-21000-8	SCR, SHC (8-32x.62)SLUG BLADE	87
3	3	-	A	2-21000-6	SCR, SHC (8-32x.38)STRIP GUIDE	86
2	2	-	A	2-21000-9	SCR, SHC (8-32x.75)R STRIP GUIDE	85
2	2	-	A	3-21000-7	SCR, SHC (10-32x.75)FEED ROD GDE	84
						83
2	2	-	A	3-21000-6	SCR, SHC (10-32x.62)FEED ADJ PL	82
1	1	-	A	3-21000-4	SCR, SHC (10-32x.38)PIVOT BLOCK	81
2	2	-	A	3-21002-0	SCR, BHC (10-32x.88)SHEAR PL	80
REF	-	-	A	455745-1	GUARD, WINDOW	79
-	REF	-	A	679532-1	INSERT, GUARD	78
						77
						76
						75
						74
						73
1	1	-	A	458109-1	WASHER, FLAT (SPECIAL)	72
1	1	-	A	690517-1	SPACER	71

POST-FEED 1 5/8 STROKE POST-FEED 1 1/8 STROKE POST-FEED 1 5/8 STROKE

1 RECOMMENDED SPARE PARTS.
 2 GREASE LIGHTLY.
 3 GUARD MUST BE IN PLACE WHEN OPERATING APPLICATOR IN A BENCH MACHINE.
 4 LUBRICATE DAILY USING NO. 20 MACHINE OIL.
 5 ITEM 78 USED WITH G TERMINATOR ONLY.
 6 FEED OFF RECEPTACLE.
 7 #16 WIRE OUT OF TERMINAL RANGE, AMP NOT RESPONSIBLE FOR CRIMP.

QTY	RECD PER ASSY	U/M	DWG SIZE	PART NO	DESCRIPTION	ITEM NO
-2	-1	U/M	DWG SIZE	PART NO	DESCRIPTION	ITEM NO

QTY	RECD PER ASSY	U/M	DWG SIZE	PART NO	DESCRIPTION	ITEM NO
-2	-1	U/M	DWG SIZE	PART NO	DESCRIPTION	ITEM NO