

REV.	DATE	ECR NO.	DESCRIPTION
NC	07/31/05	XXXXXX	INITIAL RELEASE
A	11/02/05	XXXXXX	ADD 141/U CABLE TO DESCRIPTION
B	07/30/13	2502	MODIFY DESCRIPTION, ADD ELECTRICAL & MECHANICAL NOTES; UPDATE FORMAT

RECOMMENDED
CABLE STRIPPING DIM'S

RECOMMENDED
MOUNTING HOLE

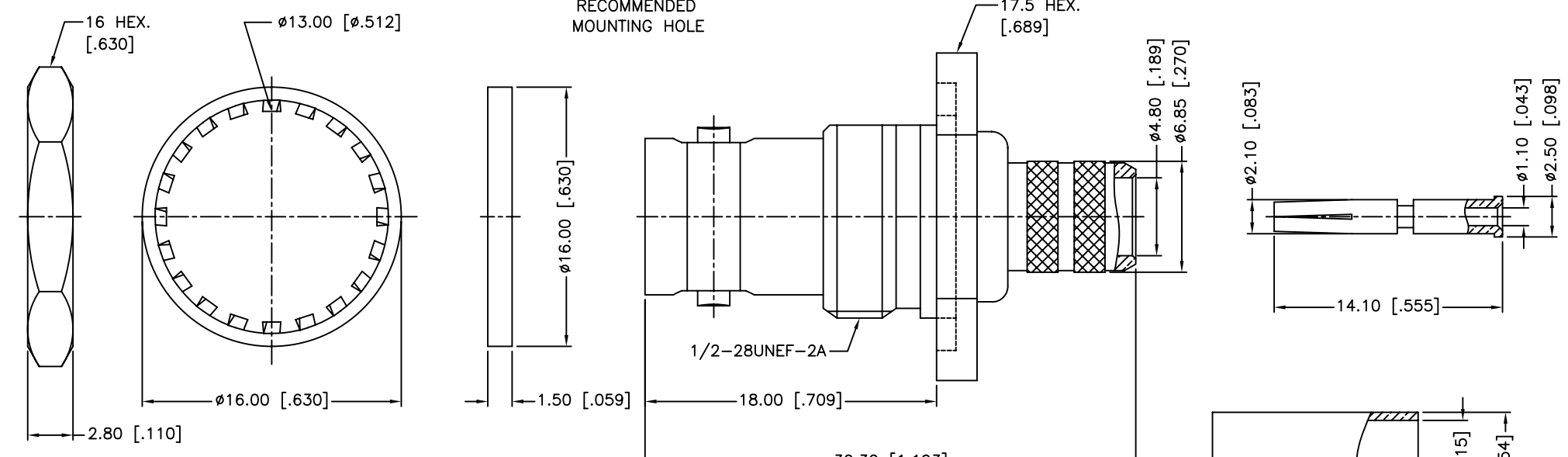

1. IMPEDANCE: 75 OHM
2. FREQUENCY RANGE: 0-2 GHZ
3. VSWR: 1.3 MAX.
4. DIELECTRIC WITHSTANDING VOLTAGE: 300 VRMS, MIN.
5. DURABILITY: 500 CYCLES MIN.
6. TEMPERATURE RANGE: -65°C TO +165°C
7. CRIMPED FERRULE
HEX. CRIMP SIZE .320"
8. CRIMPED CONTACT PIN
HEX. CRIMP SIZE .068"
9. MAX. PANEL THICKNESS=3.5mm

QTY	DESCRIPTION	MATERIAL	FINISH	QTY
9	FERRULE	BRASS	NICKEL	1
8	CONTACT PIN	PHOSPHOR BRONZE	GOLD	1
7	HEX NUT	BRASS	NICKEL	1
6	LOCK WASHER	BRASS	NICKEL	1
5	GASKET	RUBBER	RED	1
4	BARREL	BRASS	NICKEL	1
3	INSULATOR	PTFE	NATURAL	1
2	BODY	BRASS	NICKEL	1
1	HOUSING	BRASS	NICKEL	1

UNLESS OTHERWISE SPECIFIED DIMENSIONS ARE IN MILLIMETERS. DIMENSIONS IN [] ARE IN INCHES AND FOR CUSTOMER REFERENCE ONLY.
UNLESS OTHERWISE SPECIFIED
TOLERANCES FOR MILLIMETERS ARE:
 <0.5 ± 0.05mm
 0.5 - 6mm ± 0.10mm
 6 - 30mm ± 0.20mm
 30 - 120mm ± 0.30mm
 ANGLES ± 1°
 UNLESS OTHERWISE SPECIFIED
 TOLERANCES FOR INCHES ARE:
 <.020 ± 0.002"
 .020 - .236 ± 0.004"
 .236 - 1.180 ± 0.007"
 1.180 - 4.724 ± 0.012"
 ANGLES ± 1°
 DO NOT SCALE DRAWING

APPROVALS	DATE
DRAWN M.ZHANG	07/30/13
CHECKED	
ISSUED	
SHEET 1 OF 1	
CAD FILE C:/CONNEX/112732.DWG	

Amphenol Connex

PART DESCRIPTION
**BNC 75 OHM BULKHEAD CRIMP JACK
(FOR RG-6/U CABLE)**

PART NO.
112732

DWG. NO. 112732.DWG REV. B SIZE A SCALE NA