

# OPTION C

- NOTES:
- MATERIAL:  
HOUSING: POLYESTER(PBT), GLASS FILLED, UL94 V-0;  
COLOR: BLACK  
TERMINAL: PHOSPHOR BRONZE
  - FINISH:  
TIN: 3.81 MICROMETERS/150 MICROINCHES MINIMUM TIN  
OVER NICKEL UNDERPLATE OVERALL
  - TO BE USED WITH 22 AWG STRANDED WIRE WITH (1.35)/.053  
DIAMETER MAXIMUM INSULATION
  - SEE TABLE FOR AVAILABLE CIRCUIT SIZES
  - STANDARD PACKAGING PER PK-70873-0001. OPTIONAL PACKAGING  
MAY BE AVAILABLE, REQUEST DRAWING PK-70400
  - PARTS STACKABLE END TO END ON (2.54)/.100 CENTERS
  - PRODUCT SPECIFICATION: PS-70400
  - SEE DRAWING SDA-70400-\*\*\*\* (SHEET 3) FOR OPTIONAL  
HOUSING DETAILS
  - 4 CIRCUIT SHOWN. 3-25 CIRCUITS HAVE 2 RIBS
  - TO MATE WITH MOLEX PART NUMBERS: A-70374-\*\*\*\*,  
A-70376-\*\*\*\*, A-70390-\*\*\*\*, A-70392-\*\*\*\*,  
A-70544-\*\*\*\*, A-70554-\*\*\*\*, A-70542-\*\*\*\*,  
A-70552-\*\*\*\*, A-70546-\*\*\*\*, A-70556-\*\*\*\*,
  - 2 CIRCUIT ASSEMBLIES SUPPLIED AS GROUPED PAIRS

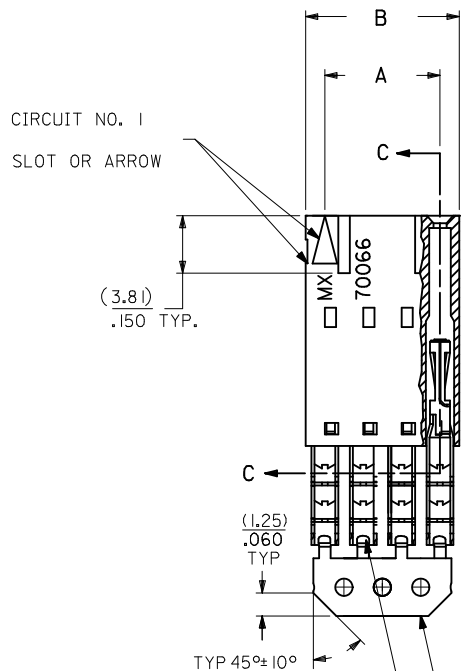

## SECTION C-C

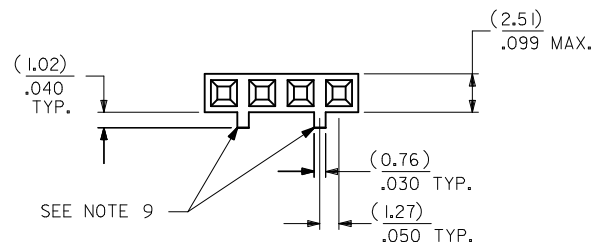
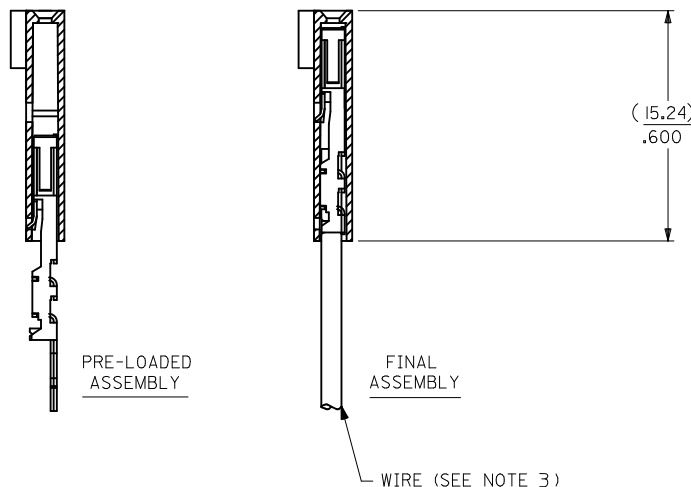

CKT. SIZE	A	B	EDP. NO.
2	( 2.54 ) .100	( 5.05 ) .199	14-56-7020
3	( 5.08 ) .200	( 7.59 ) .299	14-56-7030
4	( 7.62 ) .300	( 10.13 ) .399	14-56-7040
5	( 10.16 ) .400	( 12.67 ) .499	14-56-7050
6	( 12.70 ) .500	( 15.21 ) .599	14-56-7060
7	( 15.24 ) .600	( 17.75 ) .699	14-56-7070
8	( 17.78 ) .700	( 20.29 ) .799	14-56-7080
9	( 20.32 ) .800	( 22.83 ) .899	14-56-7090
10	( 22.86 ) .900	( 25.37 ) .999	14-56-7100
11	( 25.54 ) 1.000	( 27.91 ) 1.099	14-56-7110
12	( 27.94 ) 1.100	( 30.45 ) 1.199	14-56-7120
13	( 30.48 ) 1.200	( 32.99 ) 1.299	14-56-7130
14	( 33.02 ) 1.300	( 35.53 ) 1.399	14-56-7140
15	( 35.56 ) 1.400	( 38.07 ) 1.499	14-56-7150
16	( 38.01 ) 1.500	( 40.61 ) 1.599	14-56-7160
17	( 40.64 ) 1.600	( 43.15 ) 1.699	14-56-7170
18	( 43.18 ) 1.700	( 45.69 ) 1.799	14-56-7180
19	( 45.72 ) 1.800	( 48.23 ) 1.899	14-56-7190
20	( 48.26 ) 1.900	( 50.77 ) 1.999	14-56-7200
21	( 50.80 ) 2.000	( 53.31 ) 2.099	14-56-7210
22	( 53.34 ) 2.100	( 55.85 ) 2.199	14-56-7220
23	( 55.88 ) 2.200	( 58.39 ) 2.299	14-56-7230
24	( 58.42 ) 2.300	( 60.93 ) 2.399	14-56-7240
25	( 60.96 ) 2.400	( 63.47 ) 2.499	14-56-7250

I.D. SLOT CODE TO WIRE GAUGE CHART	
I.D. SLOT CODE	WIRE GAUGE
D	22 AWG.

PLATING CODE (STRIPE ON CARRIER STRIP)	
PLATING	COLOR
TIN	NONE

REMOVE ENG NO. EC NO: UCP2011-110 2010/10/19 DRWINMSI BARRA 2010/10/19 CHKD:J MORGAN 2010/11/24 APPR:SMILLER	QUALITY SYMBOLS ▽=0 ▽=0 ▽=0	GENERAL TOLERANCES (UNLESS SPECIFIED)	DIMENSION STYLE MM/IN	SCALE	DESIGN UNITS INCH	THIRD ANGLE PROJECTION
		4 PLACES ± --- ± --- 3 PLACES ± --- ± .010 2 PLACES ± 0.25 ± .014 1 PLACE ± 0.35 ± --- ANGULAR ± 1/2°	DRAWN BY MSI BARRA DATE 2010/10/20	CHECKED BY WAZ DATE 1987/10/26	TITLE ASSEMBLY, SL CONNECTOR SINGLE ROW 2.54/.100 GRID	MOLEX INCORPORATED
DRAFT WHERE APPLICABLE MUST REMAIN WITHIN DIMENSIONS		APPROVED BY SMILLER DATE 2010/11/24	MATERIAL NO. SEE TABLE	DOCUMENT NO. SDA-70400-3035-3058	SHEET NO. 1 OF 1	
THIS DRAWING CONTAINS INFORMATION THAT IS PROPRIETARY TO MOLEX INCORPORATED AND SHOULD NOT BE USED WITHOUT WRITTEN PERMISSION						