

LEVER BODY

Glass-fibre reinforced polyamide based (PA) technopolymer, grey-black colour, matte finish. Red writing "PUSH" tampoprinted on the lever body (avoid contact with solvents, alcohol or detergents containing alcohol).

STANDARD EXECUTIONS

Glass-fibre reinforced technopolymer clamping element, black colour, with knurling on the protruding part to make initial tightening easier. AISI 302 stainless steel return spring.

- **ERS-A:** black-oxide steel boss, threaded blind hole.
- **ERS-B:** brass boss, threaded blind hole.
- **ERS-p:** black-oxide steel threaded stud, chamfered flat end UNI 947 : ISO 4753 (see Technical data on page A-10).

STRESS RESISTANCE

See ERX, page 324.

INSTRUCTIONS OF USE

For clamping, push the lever to engage the clamping device toothing and turn it. By releasing the lever, the return spring automatically disengages the toothing and the lever returns to its rest position.

In case of accidental shocks, the lever turns freely without affecting the clamping action.



ERGOSTYLE® ELESA Original design

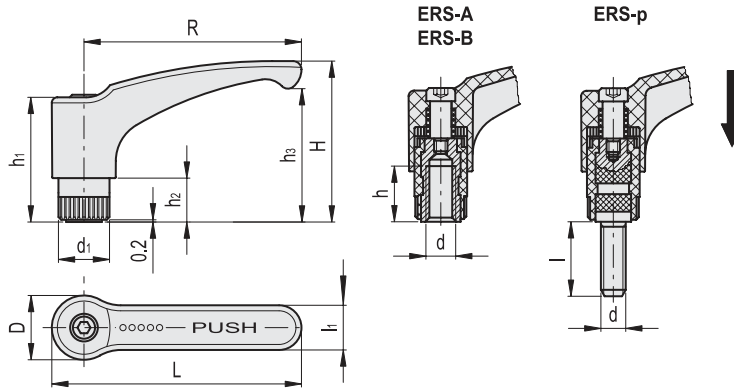

Conversion Table	
1 mm = 0.039 inch	
R	
mm	inch
44	1.73
63	2.48

**ERS-A
ERS-B**

METRIC

Code	Description	R	d6H	L	D	H	h	h1	h2	h3	d1	l1	Teeth no.	⚖
236902	ERS.44 A-M4	44	M4	52	16	36	10	29	9	28	12	11	18	14
236903	ERS.44 A-M5	44	M5	52	16	36	10	29	9	28	12	11	18	13
236904	ERS.44 A-M6	44	M6	52	16	36	10	29	9	28	12	11	18	12
236913	ERS.63 A-M6	63	M6	72.5	19	48	13	37	12	37	15	13.5	20	25
236914	ERS.63 A-M8	63	M8	72.5	19	48	13	37	12	37	15	13.5	20	24
236935	ERS.63 B-M8	63	M8	72.5	19	48	13	37	12	37	15	13.5	20	24

ERS-p

Code	Description	R	d6g	L	D	H	h1	h2	h3	d1	l	l1	Teeth no.	⚖
236972	ERS.44 p-M6x16	44	M6	52	16	36	29	9	28	12	16	11	18	18
236974	ERS.44 p-M6x25	44	M6	52	16	36	29	9	28	12	25	11	18	21
237003	ERS.63 p-M8x20	63	M8	72.5	19	48	37	12	37	15	20	13.5	20	38
237005	ERS.63 p-M8x30	63	M8	72.5	19	48	37	12	37	15	30	13.5	20	43



Clamping levers