

ORDER NO.	WOODHEAD NO.	COLOR
130145-0034	27T49	BLACK

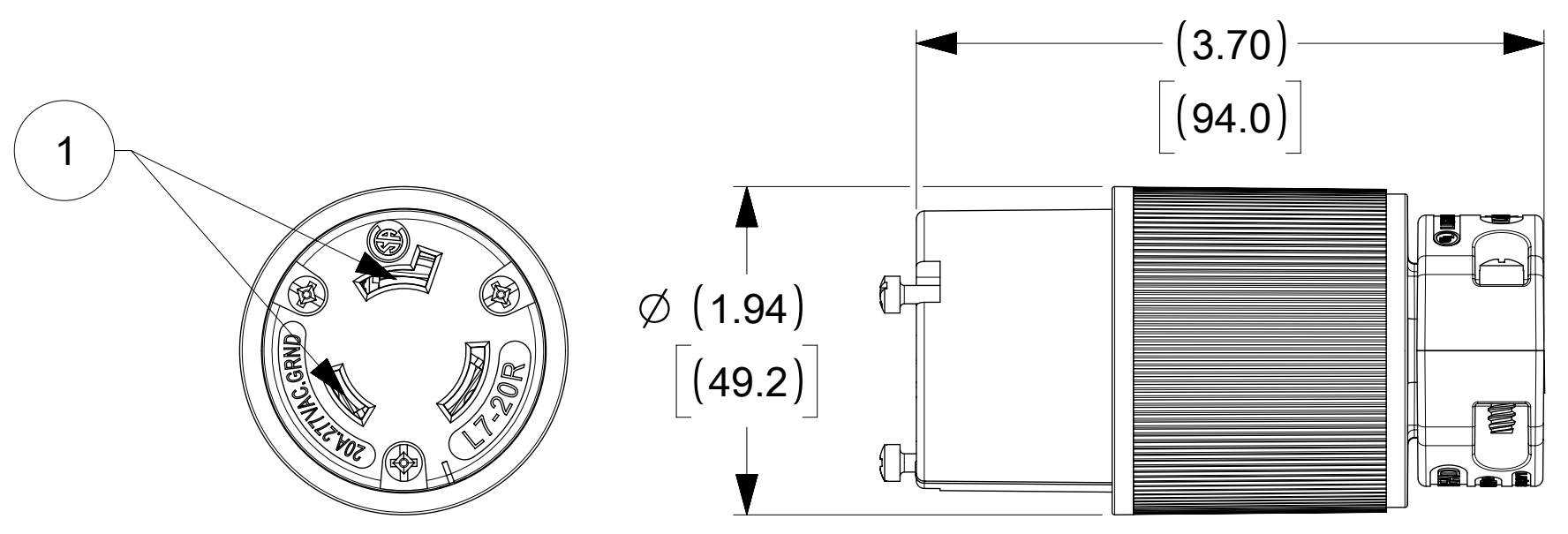

FACE VIEW

WIRING TERMINATION

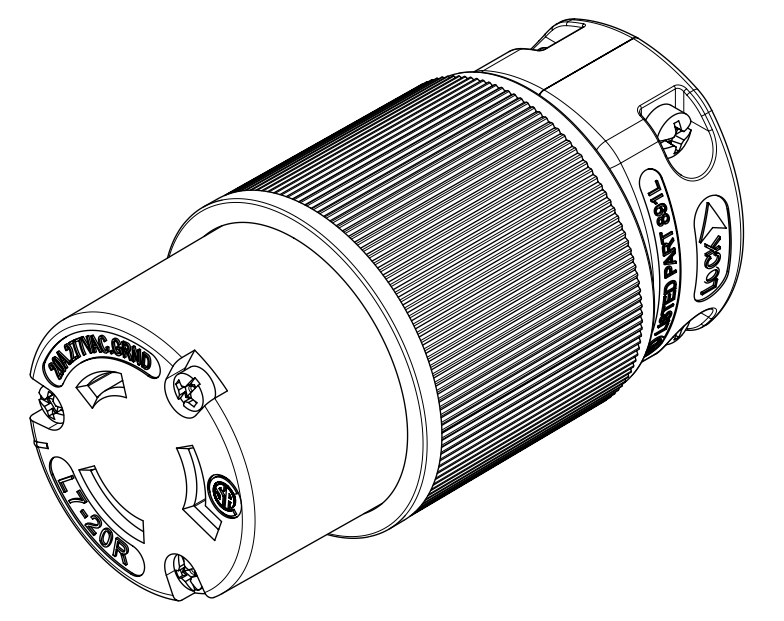
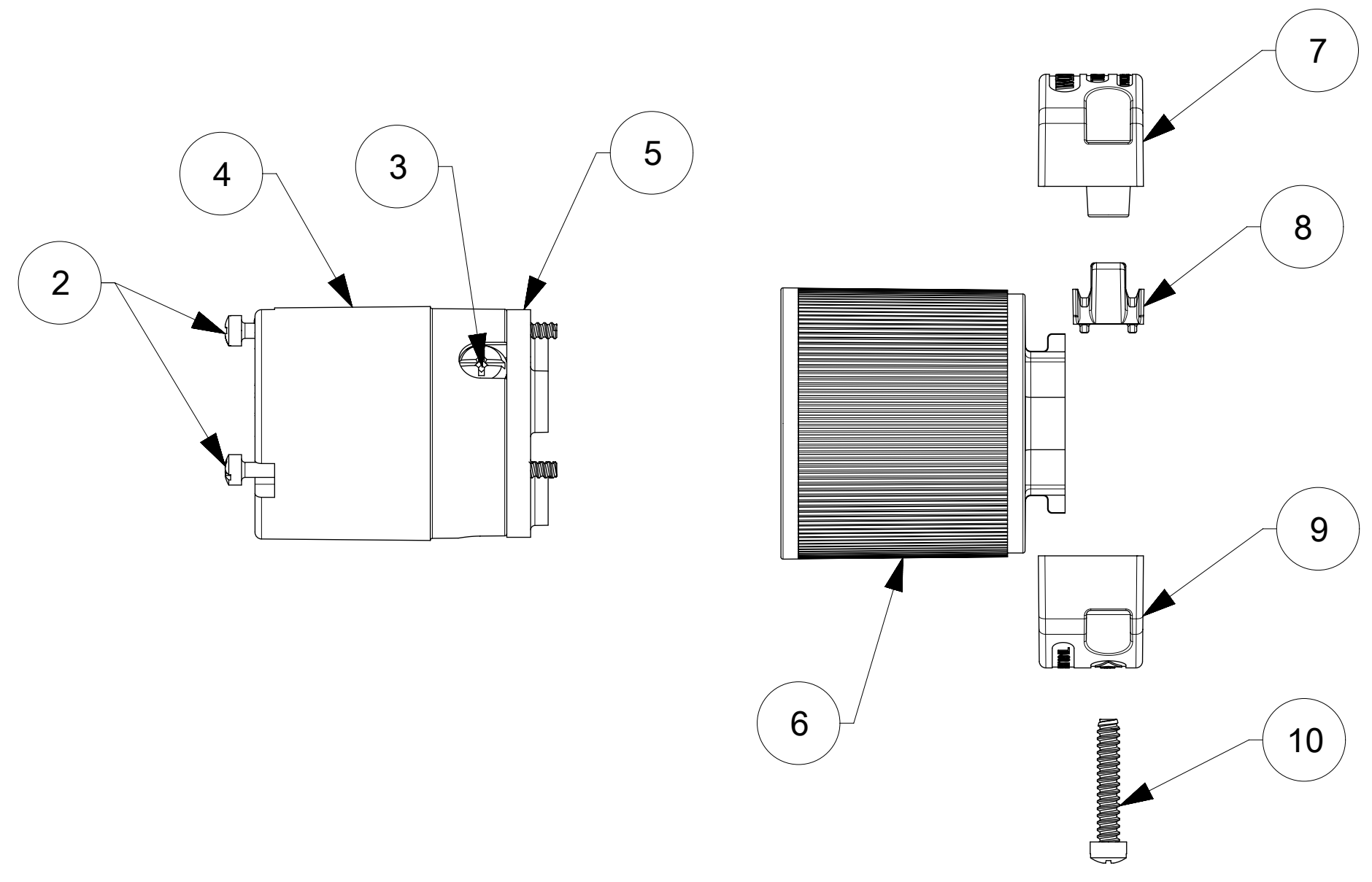
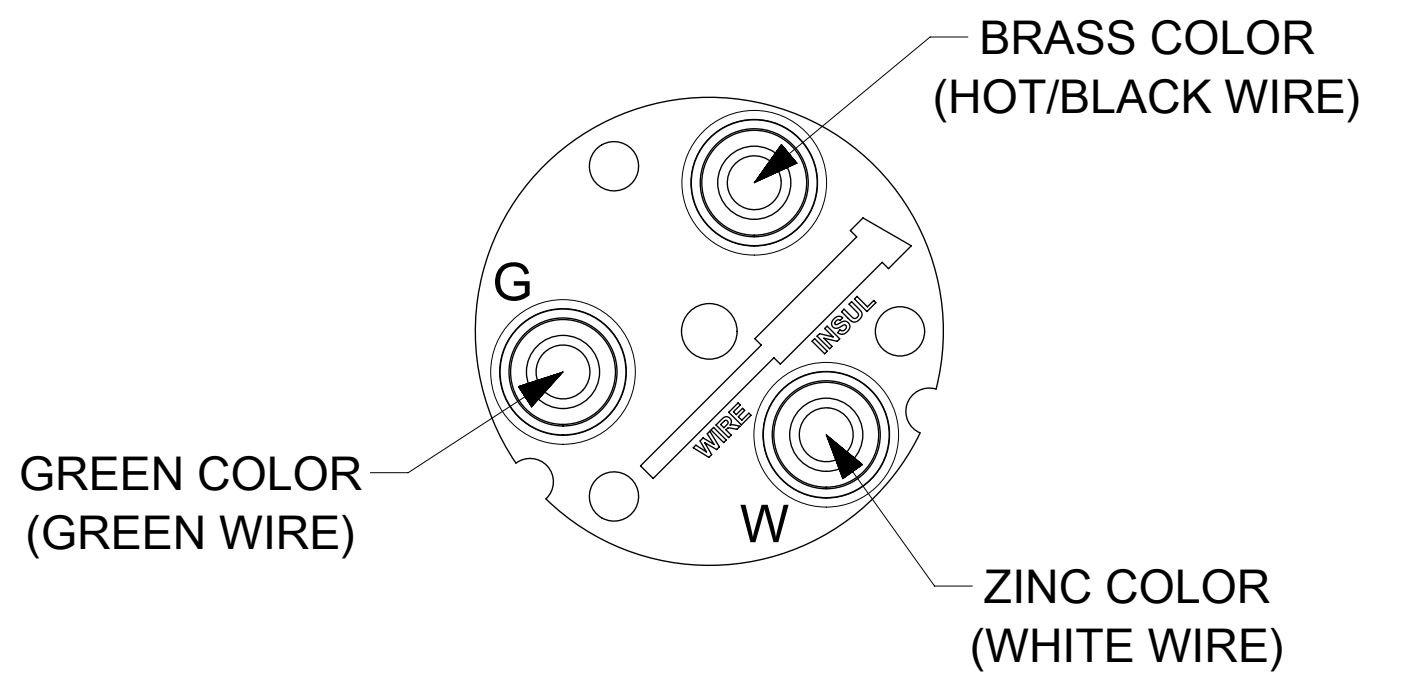

ITEM NO.	DESCRIPTIONS	MATERIAL	QTY.
1	BLADES	BRASS	3
2	RETAINING SCREWS	STAINLESS STEEL	3
3	TERMINAL SCREWS/CLAMP ASSEMBLY	BRASS, ZINC PLATED	3
4	INSERT	NYLON	1
5	TERMINAL COVER	POLYCARBONATE	1
6	HOUSING	NYLON	1
7	CLAMP CORD MALE	NYLON	1
8	CLAMP CORD INSERT	NYLON	1
9	CLAMP CORD FEMALE	NYLON	1
10	RETAINING SCREWS	STAINLESS STEEL	2

SYMBOLS DIMENSION UNITS: INCH[MM] SCALE: NTS CURRENT REV DESC: NEW RELEASE		molex SAFEWAY CONNECTOR TURNEX 2P3W L7-20	
GENERAL TOLERANCES (UNLESS SPECIFIED) 4 PLACES ± 3 PLACES ± 2 PLACES ± 1 PLACE ± 0 PLACES ±		EC NO: 627362 DRWN: VBASUTHKARP 2019/02/27 CHK'D: DNGUYEN62 2019/11/22 APPR: HKNEELAND 2020/01/13	
DRAFT WHERE APPLICABLE MUST REMAIN WITHIN DIMENSIONS		INITIAL REVISION: DRWN: VBASUTHKARP 2019/02/27 APPR: HKNEELAND 2020/01/13	
THIRD ANGLE PROJECTION		DOCUMENT NUMBER: 1301450034 DOC TYPE: PSD DOC PART: 000 REVISION: A	
C-SIZE		MATERIAL NUMBER: SEE TABLE CUSTOMER: GENERAL MARKET SHEET NUMBER: 1 OF 1	