

# Product data sheet

Specifications



safety module, Harmony XPS, time delayed output, for Estop, guard, OSSD, 24V AC or DC, spring

XPSBAT12A1AC

## Main

<b>Range of product</b>	Harmony Safety Automation
<b>Product or component type</b>	Safety module
<b>Safety module name</b>	XPSBAT
<b>Safety module application</b>	For emergency stop and protective guard applications For OSSD monitoring
<b>Function of module</b>	Emergency stop button with 2 NC contacts Guard monitoring with 1 or 2 limit switches Light curtain monitoring RFID switch Monitoring of electro-sensitive protection equipment (ESPE)
<b>Safety level</b>	Can reach PL e/category 4 for normally open relay contact ISO 13849-1 Can reach SILCL 3 for normally open relay contact IEC 62061 Can reach SIL 3 for normally open relay contact IEC 61508 Can reach PL c/category 1 for normally closed relay contact ISO 13849-1 Can reach SILCL 1 for normally closed relay contact IEC 62061 Can reach SIL 1 for normally closed relay contact IEC 61508
<b>Safety reliability data</b>	MTTFd > 30 years ISO 13849-1 Dcavg >= 99 % ISO 13849-1 PFHd = 0.98E-09 for SS0 ISO 13849-1 PFHd = 0.96E-09 for SS1 ISO 13849-1 HFT = 1 IEC 62061 PFHd = 0.98E-09 for SS0 IEC 62061 PFHd = 0.96E-09 for SS1 IEC 62061 SFF > 99% IEC 62061 HFT = 1 IEC 61508-1 PFHd = 0.98E-09 for SS0 IEC 61508-1 PFHd = 0.96E-09 for SS1 IEC 61508-1 SFF > 99% IEC 61508-1 Type = B IEC 61508-1
<b>Electrical circuit type</b>	NC pair OSSD pair
<b>Connections - terminals</b>	Removable spring terminal block, 0.2...2.5 mm <sup>2</sup> solid or flexible Removable spring terminal block, 0.25...2.5 mm <sup>2</sup> flexible with ferrule single conductor Removable spring terminal block, 0.2...1.5 mm <sup>2</sup> solid or flexible twin conductor Removable spring terminal block, 2 x 0.25...1 mm <sup>2</sup> flexible with ferrule without cable end, with bezel Removable spring terminal block, 2 x 0.5...1.5 mm <sup>2</sup> flexible with ferrule with cable end, with bezel
<b>[Us] rated supply voltage</b>	24 V AC - 15...10 % 24 V DC - 20...20 %

## Complementary

<b>Synchronisation time between inputs</b>	0.5 s 2 s
<b>Type of start</b>	Automatic/manual/monitored
<b>Power consumption in W</b>	2 W 24 V DC
<b>Power consumption in VA</b>	5 VA 24 V AC 50/60 Hz

<b>Input protection type</b>	Internal, electronic
<b>Safety outputs</b>	2 NO immediate 1 NO configurable
<b>Safety inputs</b>	2 positive safety input 24 V DC 5 mA
<b>Maximum wire resistance</b>	500 Ohm
<b>Time delay range</b>	0...900 s off
<b>Input compatibility</b>	Normally closed circuit ISO 14119 Mechanical contact ISO 14119 OSSD pair IEC 61496-1-2 Normally closed circuit ISO 13850 3-wire proximity sensors PNP
<b>[Ie] rated operational current</b>	5 A AC-1 for normally open relay contact 3 A AC-15 for normally open relay contact 5 A DC-1 for normally open relay contact 3 A DC-13 for normally open relay contact
<b>Control outputs</b>	3 on/off configurable pulsed output
<b>Input/Output type</b>	Semiconductor output 24 V DC, 20 mA Z1, not safety-related
<b>[Ith] conventional free air thermal current</b>	12 A
<b>Associated fuse rating</b>	6 A gG NO relay output circuit IEC 60947-1
<b>Minimum output current</b>	20 mA relay output
<b>Minimum output voltage</b>	24 V relay output
<b>Maximum response time on input open</b>	20 ms
<b>[Ui] rated insulation voltage</b>	250 V 2)EN/IEC 60947-1
<b>[Uimp] rated impulse withstand voltage</b>	4 kV II EN/IEC 60947-1
<b>Local signalling</b>	LED green power power ON LED red error error LED yellow state 1 safety output instantaneous LED yellow state 2 safety output delayed LED yellow start 1 start LED yellow start 2 start LED yellow S12 safety input S12 LED yellow S22 safety input S22
<b>Mounting support</b>	35 mm symmetrical DIN rail
<b>Depth</b>	4.72 in (120 mm)
<b>Height</b>	3.94 in (100 mm)
<b>Width</b>	0.89 in (22.5 mm)
<b>Product weight</b>	0.77 lb(US) (0.350 kg)

## Environment

<b>Standards</b>	IEC 60947-5-1 IEC 61508-1 functional safety standard IEC 61508-2 functional safety standard IEC 61508-3 functional safety standard IEC 61508-4 functional safety standard IEC 61508-5 functional safety standard IEC 61508-6 functional safety standard IEC 61508-7 functional safety standard ISO 13849-1 functional safety standard IEC 62061 functional safety standard
<b>Product certifications</b>	TÜV cULus
<b>IP degree of protection</b>	IP20 terminals)EN/IEC 60529 IP40 housing)EN/IEC 60529 IP54 mounting area)EN/IEC 60529
<b>Ambient air temperature for operation</b>	-13...131 °F (-25...55 °C)

---

<b>Ambient air temperature for storage</b>	-13...185 °F (-25...85 °C)
--	----------------------------

---

<b>Relative humidity</b>	5...95 % non-condensing
--------------------------	-------------------------

---

## Packing Units

---

<b>Unit Type of Package 1</b>	PCE
-------------------------------	-----

---

<b>Number of Units in Package 1</b>	1
-------------------------------------	---

---

<b>Package 1 Height</b>	2.68 in (6.8 cm)
-------------------------	------------------

---

<b>Package 1 Width</b>	5.43 in (13.8 cm)
------------------------	-------------------

---

<b>Package 1 Length</b>	6.10 in (15.5 cm)
-------------------------	-------------------

---

<b>Package 1 Weight</b>	10.30 oz (292.0 g)
-------------------------	--------------------

---

<b>Unit Type of Package 2</b>	S03
-------------------------------	-----

---

<b>Number of Units in Package 2</b>	16
-------------------------------------	----

---

<b>Package 2 Height</b>	11.81 in (30 cm)
-------------------------	------------------

---

<b>Package 2 Width</b>	11.81 in (30 cm)
------------------------	------------------

---

<b>Package 2 Length</b>	15.75 in (40 cm)
-------------------------	------------------

---

<b>Package 2 Weight</b>	11.92 lb(US) (5.409 kg)
-------------------------	-------------------------

---

## Offer Sustainability

---

<b>Sustainable offer status</b>	Green Premium product
---------------------------------	-----------------------

---

<b>REACH Regulation</b>	<a href="#">REACH Declaration</a>
-------------------------	-----------------------------------

---

<b>EU RoHS Directive</b>	Pro-active compliance (Product out of EU RoHS legal scope) <a href="#">EU RoHS Declaration</a>
--------------------------	---

---

<b>Mercury free</b>	Yes
---------------------	-----

---

<b>China RoHS Regulation</b>	<a href="#">China RoHS declaration</a>
------------------------------	--

---

<b>RoHS exemption information</b>	<a href="#">Yes</a>
-----------------------------------	---------------------

---

<b>Environmental Disclosure</b>	<a href="#">Product Environmental Profile</a>
---------------------------------	---

---

<b>Circularity Profile</b>	<a href="#">End of Life Information</a>
----------------------------	---

---

<b>WEEE</b>	The product must be disposed on European Union markets following specific waste collection and never end up in rubbish bins
-------------	---



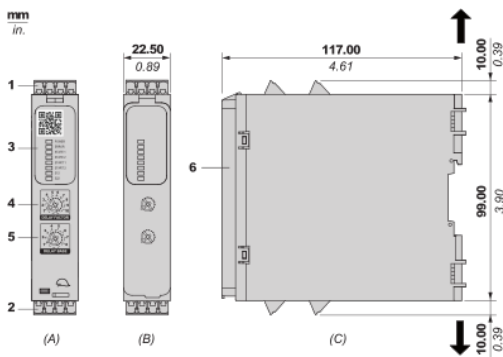

---

**Dimensions**

**Front and Side Views**



- (A) : Product drawing
- (B) : Spring terminal
- (C) : Side view
- (1) : Removable terminal blocks, top
- (2) : Removable terminal blocks, bottom
- (3) : LED indicators
- (4) : Delay factor selector
- (5) : Delay base selector
- (6) : Sealable transparent cover

mm in.	12.0 0.47					
mm <sup>2</sup>		0,2...2,5	0,25...2,5	0,2...1,5	0,25...1	0,5...1,5
AWG		24...12	24...12	24...16	24...18	20...16

Mounting to DIN rail

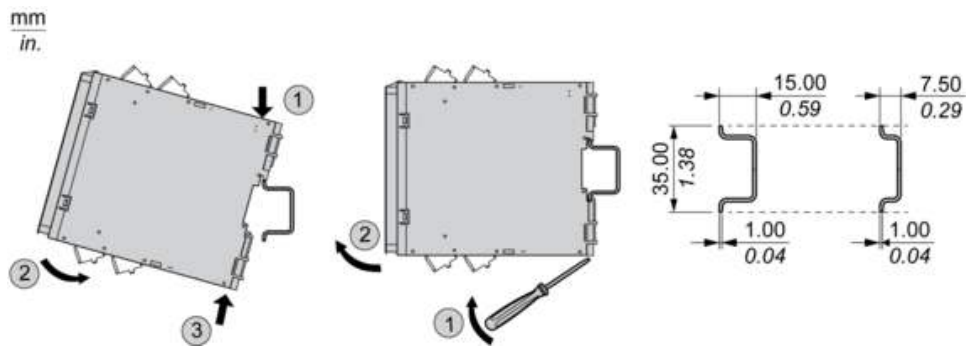

Screw-mounting

mm  
in.

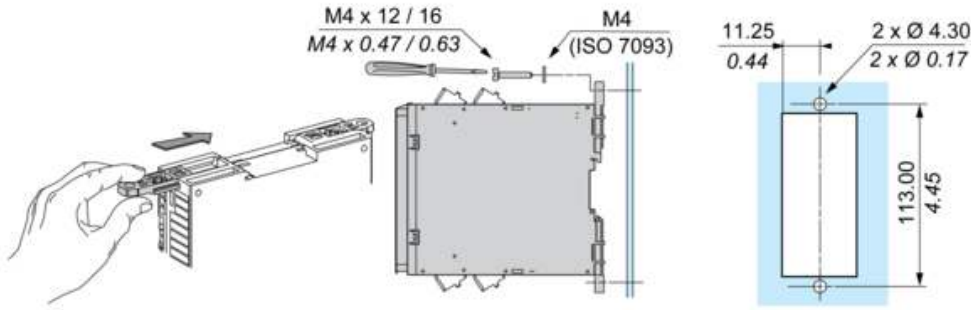

**Wiring Diagram**

---

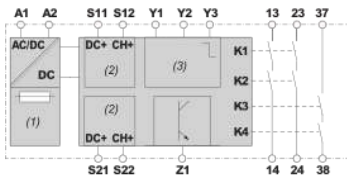

(1) : A1-A2 (Power supply)

(2) : S11–S21 (Control outputs (DC+) of safety-related inputs), S12-S22 (Input channels (CH+) of safety-related inputs)

(3) : Y1 (Control output of Start/Restart input), Y2 (Input channel for automatic/manual start), Y3 (Input channel for monitored start with falling edge)

13-14-23-24 : Terminals of the safety-related outputs (instantaneous)

37-38 : Terminals of the safety-related outputs (delayed)

Z1 : Solid state output, not safety-related

**Recommended replacement(s)**