



4D SYSTEMS
TURNING TECHNOLOGY INTO ART

Table of Content

4D ClearCore Adaptor

DATASHEET

DOCUMENT DATE: 27th January 2022 DOCUMENT
REVISION: 1.0



4D-ClearCore-Adaptor

Uncontrolled Copy when printed or downloaded.
Please refer to the 4D Systems website for the latest
Revision of this document

S

1. Description.....	3
2. Features.....	3
3. Hardware Interfaces.....	4
3.1. Teknic ClearCore Interface.....	4
3.2. Display Interfaces.....	4
3.3. Cable information.....	4
3.4. USB Connection.....	5
3.5. J1 Jumper Selection.....	5
3.6. RESET-EN Switch.....	5
4. Mounting.....	6
5. Cable Lengths.....	6
6. Included in the box.....	6
7. Mechanical Details.....	7
8. Schematic Details (HW REV 1.1).....	8
9. Connection Diagram of Teknic Clearcore to 4D Clearcore Adaptor (RJ45 Example).....	9
10. Connection Diagram of Teknic Clearcore to 4D Clearcore Adaptor (AUX Example).....	10
11. Specifications.....	11
12. Hardware Revision History.....	12
13. Datasheet Revision History.....	12
14. Legal Notice.....	13
15. Contact Information.....	13

1. Description

The 4D ClearCore Adaptor is an interfacing adaptor to enable easy connections between a Teknik Clearcore Industrial I/O Motion Controller, and a 4D Systems intelligent display, such as one of the gen4-uLCD, uLCD, uOLED, or pixxiLCD ranges.

This 4D ClearCore Adaptor enables easy connections using standard cables provided by both companies, 4D Systems and Teknik.

The 4D Clearcore Adaptor is easy to mount and easy to use, with two options for how the connected display module can be powered via the Teknik ClearCore controller.

Teknic Website:

<https://teknik.com>

Teknic ClearCore:

<https://teknik.com/products/io-motion-controller/>

For best results, it is recommended to program the Teknik ClearCore using the Arduino IDE and use the Teknik Arduino Wrapper. This can be downloaded from the Teknik website.

<https://teknik.com/products/io-motion-controller/clearcore-arduino-wrapper/>

Teknic ClearCore Arduino Wrapper, direct:

https://teknik.com/files/downloads/ClearCore_Arduino_Wrapper_Installer.zip

In conjunction with this, it is recommended to use the genieArduino Arduino Library, paired with the Workshop4 IDE and its ViSi-Genie environment.

4D Systems Workshop4 IDE:

<https://4dsystems.com.au/workshop4>

4D Systems genieArduino Library:

<https://github.com/4dsystems/ViSi-Genie-Arduino-Library-DEV>

2. Features

- Compatible with gen4-uLCD, uLCD, uOLED and PixxiLCD intelligent display ranges
- UART connection to the Teknik Clearcore using standard CAT style ethernet cable
- Standard FFC or 5-way connection to 4D Systems intelligent displays
- Capable of being powered off the ClearCore UART port (when used with 4.3" display and below), or via an Auxiliary connection to one of the spare GPIO ports on the Teknik Clearcore, or direct to a 7-30VDC power supply.
- On board programmer to enable the connected 4D Display to be programmed via USB, without the need to unplug the display from this 4D Clearcore Adaptor.
- Switch to enable or disable the RESET connection from the 4D display module to the Teknik ClearCore, allowing the ClearCore to hardware reset the display if and when desired.
- Metal mounting base enables through hole mounting of this 4D Clearcore Adaptor through 2 designated holes, using a variety of screws.
- RoHS and REACH compliant.

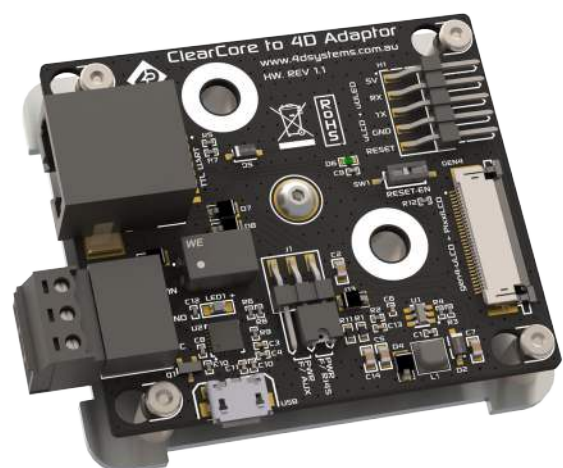

3. Hardware Interfaces

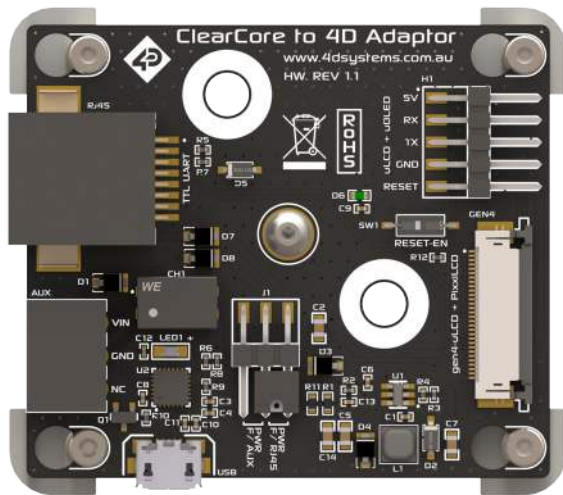

- Left Top:** RJ45 connection to ClearCore (TTL UART)
- Left Bottom:** 3 pin 3.81mm pitch AUX pluggable screw terminal for supplementary power for powering displays > 4.3". 7V-30VDC Input.
- Bottom Left:** microUSB for programming 4D Display
- Bottom Centre:** 3-pin Jumper (J1) to select between AUX power and RJ45 Power for 4D Display, using supplied shunt
- Right Bottom:** 30-way ZIF for connection to 4D Display (gen4-uLCD, pixxiLCD) – **Top Contact**
- Right Top:** 5-way Header for connection to 4D Display (uLCD or uOLED)

3.1. Teknic ClearCore Interface

The interface to the Teknic ClearCore is via the RJ45 connector on the 4D ClearCore Adaptor and uses a standard CAT5 style cable.

Connect the 4D ClearCore Adaptor to the Teknic ClearCore using either of its 5V TTL COM ports, 5V COM-0 or 5V COM-1, the only difference is which port is configured to be used in the ClearCore code.

Note: Cable is not included with this adaptor.

3.2. Display Interfaces

There are 2 options available for connecting a 4D Systems intelligent display to the 4D ClearCore

Adaptor. Only one can be connected at any given time, do not connect displays to both as there will be a conflict and they will not work.

The 30-way ZIF connector can connect a 30-way FFC cable directly to the gen4-uLCD range of display modules, or the 30-way to 15-way FFC cable can be used to connect the pixxiLCD range of display modules.

The 5-way pin male pin header can be used to connect directly to the uLCD or uOLED ranges of display modules using the standard 4D Systems 5-way cable, or it could also be used to connect to the gen4-uLCD or pixxiLCD range via the gen4-IB adaptor, 5-way cable and 30-way FFC cable.

Future display ranges may come available which can also utilize either of these interfaces.

3.3. Cable information

The FFC cables supplied by 4D Systems (**included with gen4-uLCD products**) have the following specifications:

- **30 Pin** Flexible Flat Cable, 150mm Long, 0.5mm (0.02") pitch
- Connections on the opposite side at each end (Type B)

Note: Some different length cables are available by contacting 4D Systems sales directly

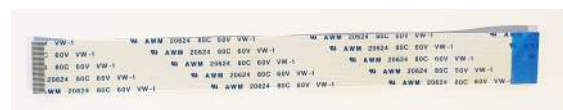

The FFC cable supplied by 4D Systems (**included with PixxiLCD products**) is a custom FFC (not FFC) which converts the 30-way into 15-way, for connecting to the pixxiLCD display modules. These are custom designed and have no standard replacement option off the shelf.

For replacements, please contact 4D Systems Sales.



The 5-way cable supplied by 4D Systems (**included with uLCD, uOLED and gen4-uLCD products**) are female to female wires in a 5-way configuration. These are standard 2.54mm (0.1") pitch cables and could be replaced with other readily available purchased cables or DIY solutions.



Cable replacements are available from 4D Systems, please contact the 4D Sales team.

3.4. USB Connection

On the Left side of the 4D ClearCore Adaptor is a microUSB connector, which is connected to a Silicon Labs CP2104 USB to UART converter, configured to program 4D Intelligent Display modules connected to either the 30-way or 5-way display interfaces.

This operates in the same way as other standard 4D Systems programmers, such as the 4D-UPA, 4D Programming cable, uUSB-PA5, etc.

This enables easy access to program the 4D display without disconnecting the display from the 4D ClearCore Adaptor.

Note: It is required that the CAT5 cable going to the ClearCore is disconnected from this 4D Clearcore Adaptor, as this will conflict with the programming signals to the display, since they share the same UART. This can be disconnected from the 4D ClearCore Adaptor end, or the ClearCore itself. Once programming of the display is completed, simply plug the CAT5 cable back in.

3.5. J1 Jumper Selection

The J1 jumper is present to enable selection of power for the display, coming from either the ClearCore UART or the AUX header.

The ClearCore is capable of supplying a total of 450mA of current over the UART itself, however this is also potentially shared by other devices

attached to the ClearCore, application dependant.

For 4.3" displays and lower, the RJ45 selection "PWR F/RJ45" should be suitable in most cases, where the ClearCore supplies power to this 4D ClearCore Adaptor and the connected 4D display, via its UART over the CAT5 cable.

For displays larger than 4.3" (can also be used for 4.3" and below), or for SB (Super Bright) variants, the AUX selection "PWR F/AUX" should be used.

The AUX connection is provided power from an external source, via the 3-pin screw terminal input. This can be from the ClearCore itself, connecting it to an unused GPIO header (Excluding I/O-4 and I/O-5), or to a DC supply 7VDC to 30VDC.

3.6. RESET-EN Switch

On the right side of the 4D ClearCore Adaptor, is a micro-switch (Reset Enable), which determines if the RTS line of the RJ45 TTL UART is connected to the RESET line of the 4D Display.

When the switch is on the ON side, the RTS line of the ClearCore is connected to the displays RESET line, enabling the ClearCore to control the hardware reset of the display.

When the switch is off, the RTS line is disconnected, and no hardware reset is possible.

Suitable software coding is required in the ClearCore application to enable the use of the RTS line as reset.

4. Mounting

The 4D ClearCore Adaptor can be easily mounted using the two through holes, using a number of different fixing options.

The holes are outlined with a large white circle, and travel through the entire depth of the adaptor using a stainless standoff.

Many types of screws could be used to mount the adaptor, choose the best option that suits the application where this is to be mounted.

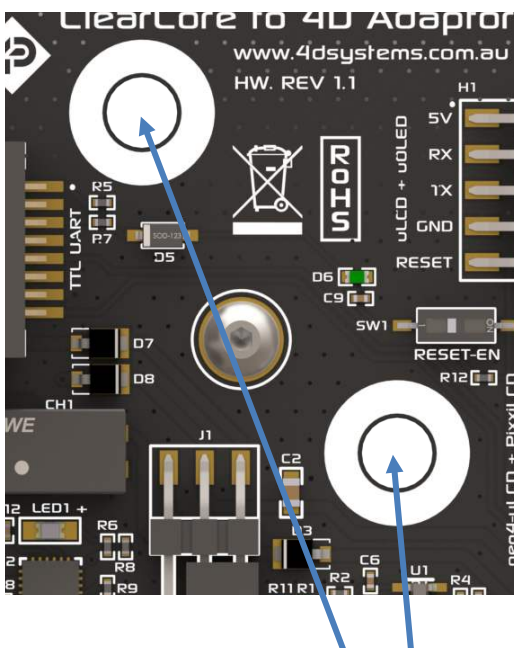

The holes are 5mm (approximately 3/16”) in size

5. Cable Lengths

The cable required for connection between the Teknic ClearCore and this 4D ClearCore Adaptor, is a standard CAT5 cable, as mentioned previously in this document.

The signals used between the Teknic ClearCore and the 4D ClearCore Adaptor are 5V TTL level signals, more specifically they are a TTL Serial UART (not RS232), accompanied with 5V power and Ground, along with an optional reset.

Due to 5V TTL Logic signals being used, a cable length < 5m (~16 ft) is recommended at 115200 Baud. If running slower, say 9600 Baud, a longer cable run could be used, however < 10m is

recommended. Length testing is required by the User and these should only be used as a guide.

When using 4D Displays larger than 4.3”, the AUX power connection is required, and therefore no 5V signal will be travelling down the length of this CAT5 cable. The AUX connection can also be used for the 4.3” or smaller displays and can be helpful especially if longer cable lengths are required. This can assist with adequate power reaching the display, due to possible drops on the 5V wire when being powered over the CAT5.

If communication issues are encountered when using longer cable lengths, it could be due to signal degradation due to the cable length itself. Either shorten the cables is required or try a lower/slower baud rate.

6. Included in the box

Inside the packaging of the 4D ClearCore Adaptor, you will find the following items:

- 4D ClearCore Adaptor – mounted on an aluminium mounting frame
- 3-way screw terminal connector, inserted into the 4D ClearCore Adaptor 3-way AUX connector

Items NOT included:

- CAT5 cable for connection to ClearCore (User lengths will vary based on requirements)
- 30-Way FFC, 30-to-15-Way FPC, or 5-way cable – these are included with 4D display products already
- microUSB Cable

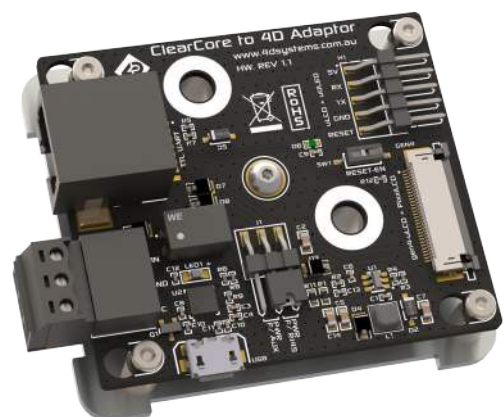

7. Mechanical Details

4D ClearCore Adaptor

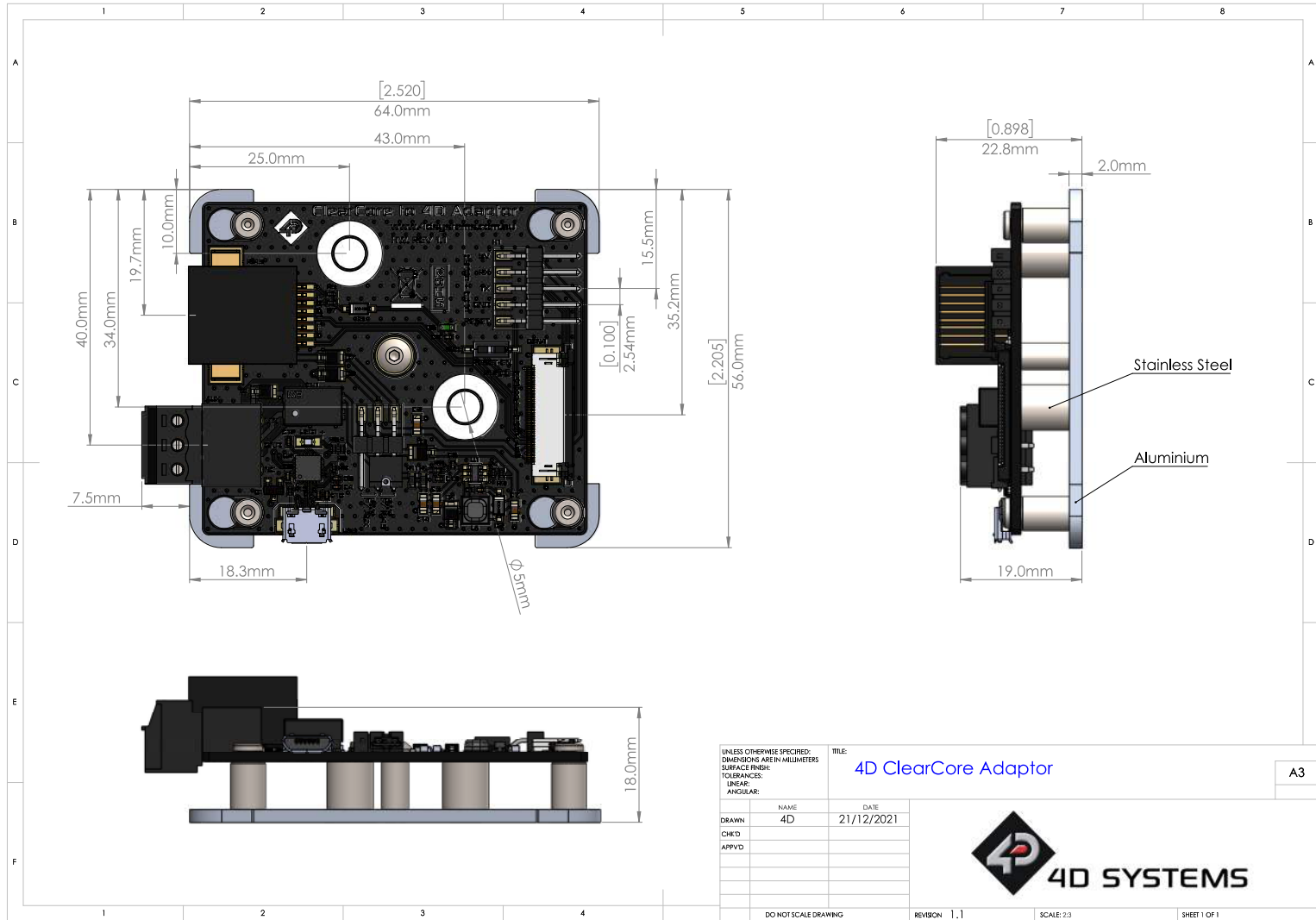

8. Schematic Details (HW REV 1.1)

4D ClearCore Adaptor

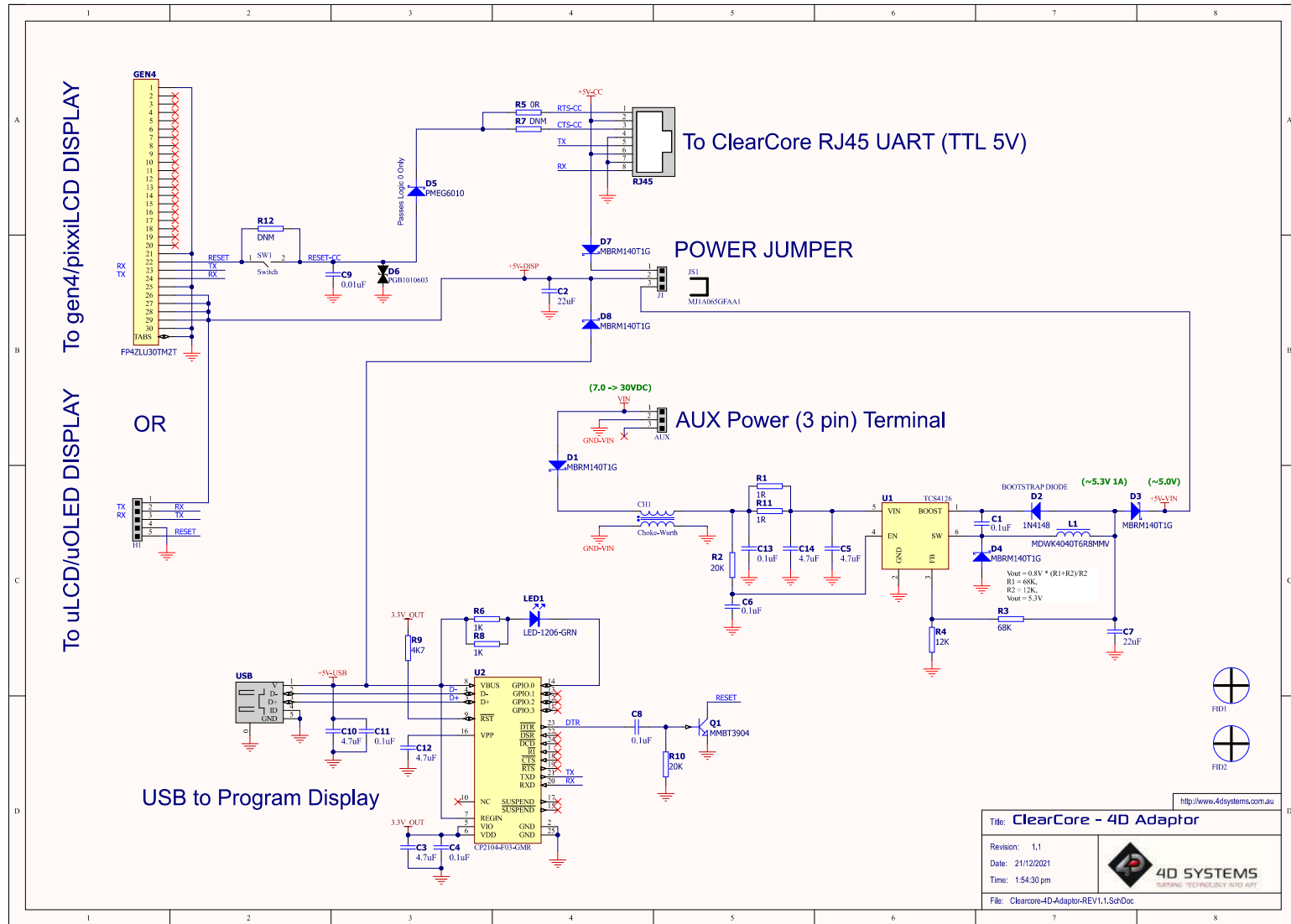

9. Connection Diagram of Teknic Clearcore to 4D Clearcore Adaptor (RJ45 Example)

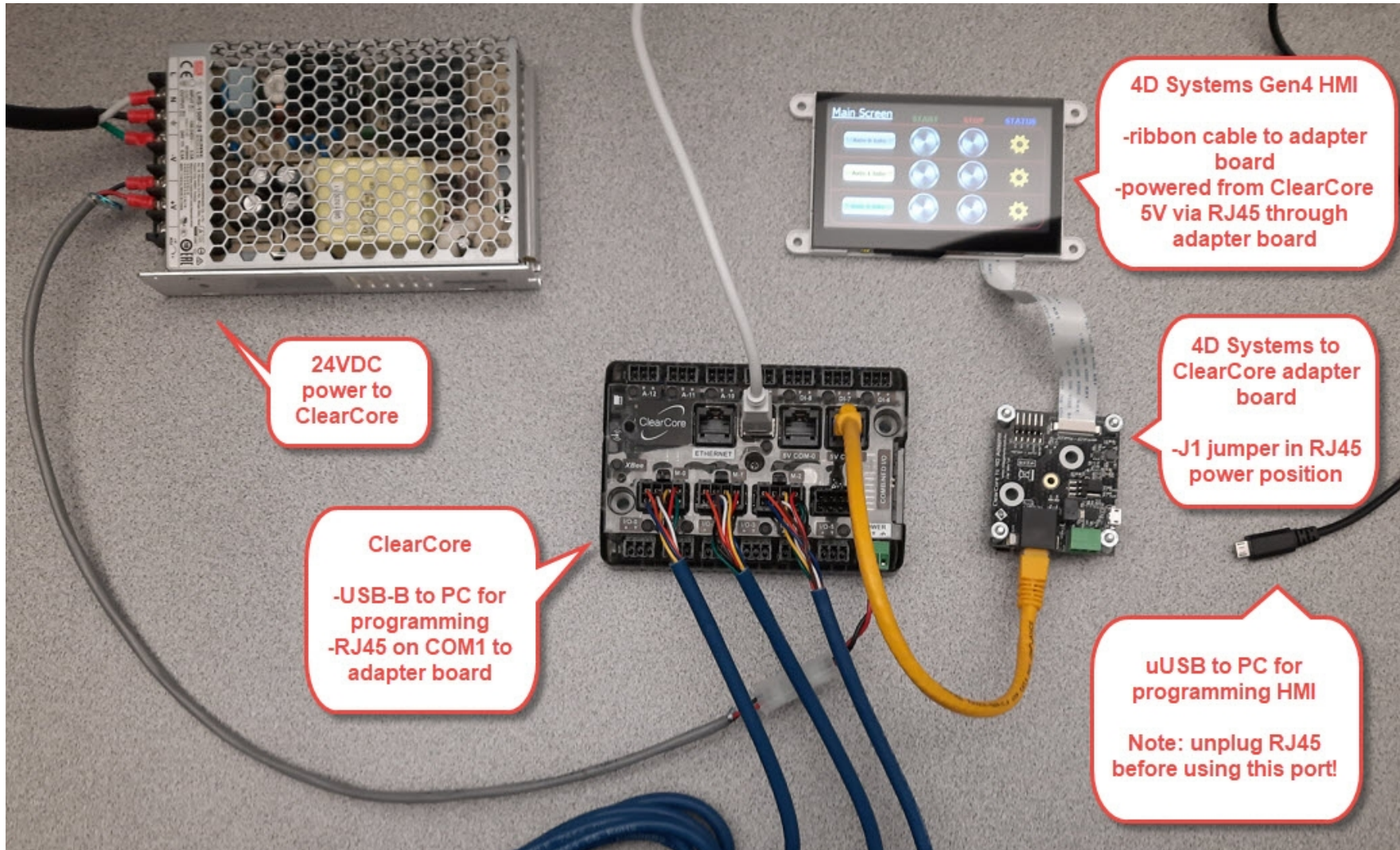

10. Connection Diagram of Teknic Clearcore to 4D Clearcore Adaptor (AUX Example)

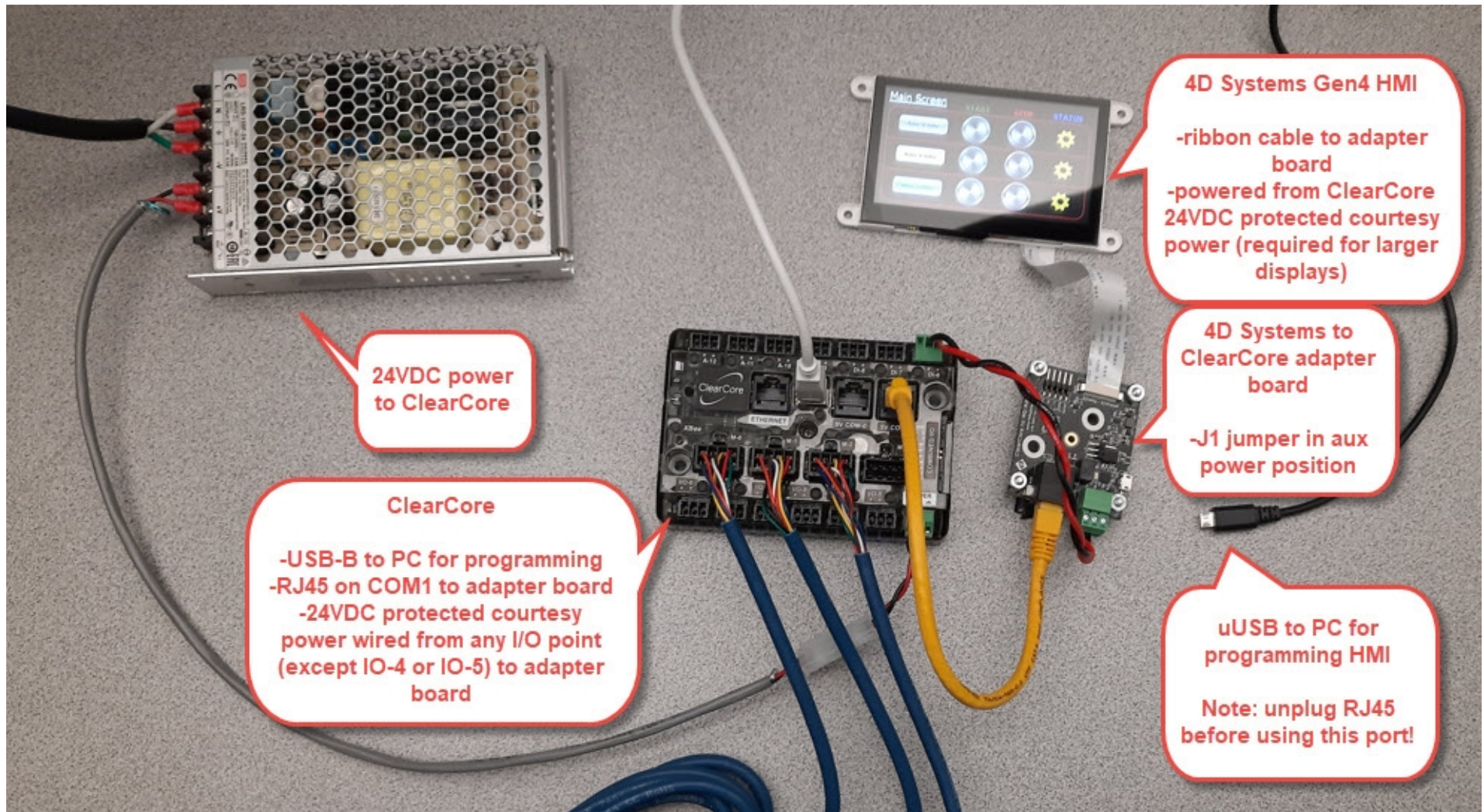

11. Specifications

ABSOLUTE MAXIMUM RATINGS

Operating ambient temperature	-20°C to +70°C
Storage temperature	-30°C +80°C

NOTE: Stresses above those listed here may cause permanent damage to the device. This is a stress rating only and functional operation of the device at those or any other conditions above those indicated in the recommended operation listings of this specification is not implied. Exposure to maximum rating conditions for extended periods may affect device reliability.

RECOMMENDED OPERATING CONDITIONS

Parameter	Conditions	Min	Typ	Max	Units
Supply Voltage (RJ45)	RJ45 Input from ClearCore	4.5	5.0	6.0	V
Supply Voltage (AUX)	AUX Input	7.0	--	30.0	V
Supply Voltage (USB)	USB Supply to program display	4.5	5.0	6.0	V

Note: For detailed specifications of what is connected to this 4D ClearCore Adaptor, please refer to the individual product datasheets for each of the 4D Systems intelligent display modules.

Note: For details specification on the ClearCore, please refer to the Teknic website and the ClearCore documentation.

Note: AUX cannot be connected to the ClearCore's I/O-4 or I/O-5 ports for power to this adaptor, as the power source for I/O-4 and I/O-5 is via an H-Bridge inside the ClearCore and is not connected to the internal 24V supply.

Proprietary Information

The information contained in this document is the property of 4D Systems Pty. Ltd. and may be the subject of patents pending or granted, and must not be copied or disclosed without prior written permission.

4D Systems endeavours to ensure that the information in this document is correct and fairly stated but does not accept liability for any error or omission. The development of 4D Systems products and services is continuous and published information may not be up to date. It is important to check the current position with 4D Systems. 4D Systems reserves the right to modify, update or makes changes to Specifications or written material without prior notice at any time.

All trademarks belong to their respective owners and are recognised and acknowledged.

Disclaimer of Warranties & Limitation of Liability

4D Systems makes no warranty, either expressed or implied with respect to any product, and specifically disclaims all other warranties, including, without limitation, warranties for merchantability, non-infringement and fitness for any particular purpose.

Information contained in this publication regarding device applications and the like is provided only for your convenience and may be superseded by updates. It is your responsibility to ensure that your application meets with your specifications.

Images and graphics used throughout this document are for illustrative purposes only. All images and graphics used are possible to be displayed on the 4D Systems range of products, however the quality may vary.

In no event shall 4D Systems be liable to the buyer or to any third party for any indirect, incidental, special, consequential, punitive or exemplary damages (including without limitation lost profits, lost savings, or loss of business opportunity) arising out of or relating to any product or service provided or to be provided by 4D Systems, or the use or inability to use the same, even if 4D Systems has been advised of the possibility of such damages.

4D Systems products are not fault tolerant nor designed, manufactured or intended for use or resale as on line control equipment in hazardous environments requiring fail – safe performance, such as in the operation of nuclear facilities, aircraft navigation or communication systems, air traffic control, direct life support machines or weapons systems in which the failure of the product could lead directly to death, personal injury or severe physical or environmental damage ('High Risk Activities'). 4D Systems and its suppliers specifically disclaim any expressed or implied warranty of fitness for High Risk Activities.

Use of 4D Systems' products and devices in 'High Risk Activities' and in any other application is entirely at the buyer's risk, and the buyer agrees to defend, indemnify and hold harmless 4D Systems from any and all damages, claims, suits, or expenses resulting from such use. No licenses are conveyed, implicitly or otherwise, under any 4D Systems intellectual property rights.

15. Contact Information

For Technical Support: www.4dsystems.com.au/support

For Sales Support: sales@4dsystems.com.au

Website: www.4dsystems.com.au

Copyright 4D Systems Pty. Ltd. 2000-2022