

THIS DRAWING IS UNPUBLISHED. RELEASED FOR PUBLICATION
 © COPYRIGHT - By - ALL RIGHTS RESERVED.

LOC	DIST	REVISIONS			
P	LTR	DESCRIPTION	DATE	DWN	APVD
FT	0	V REVISED PER ECO-12-012320	04JUL12	KH	MZ

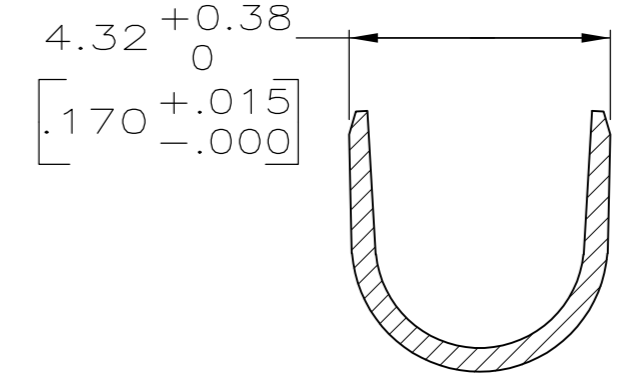
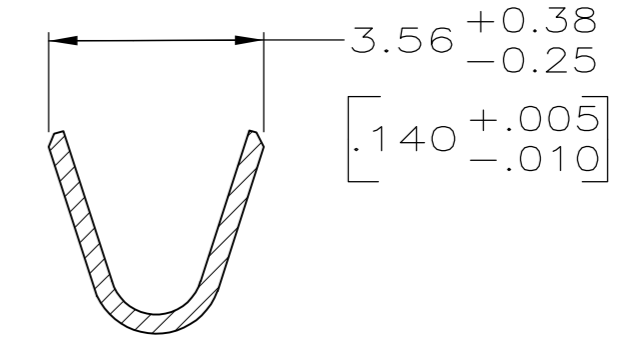
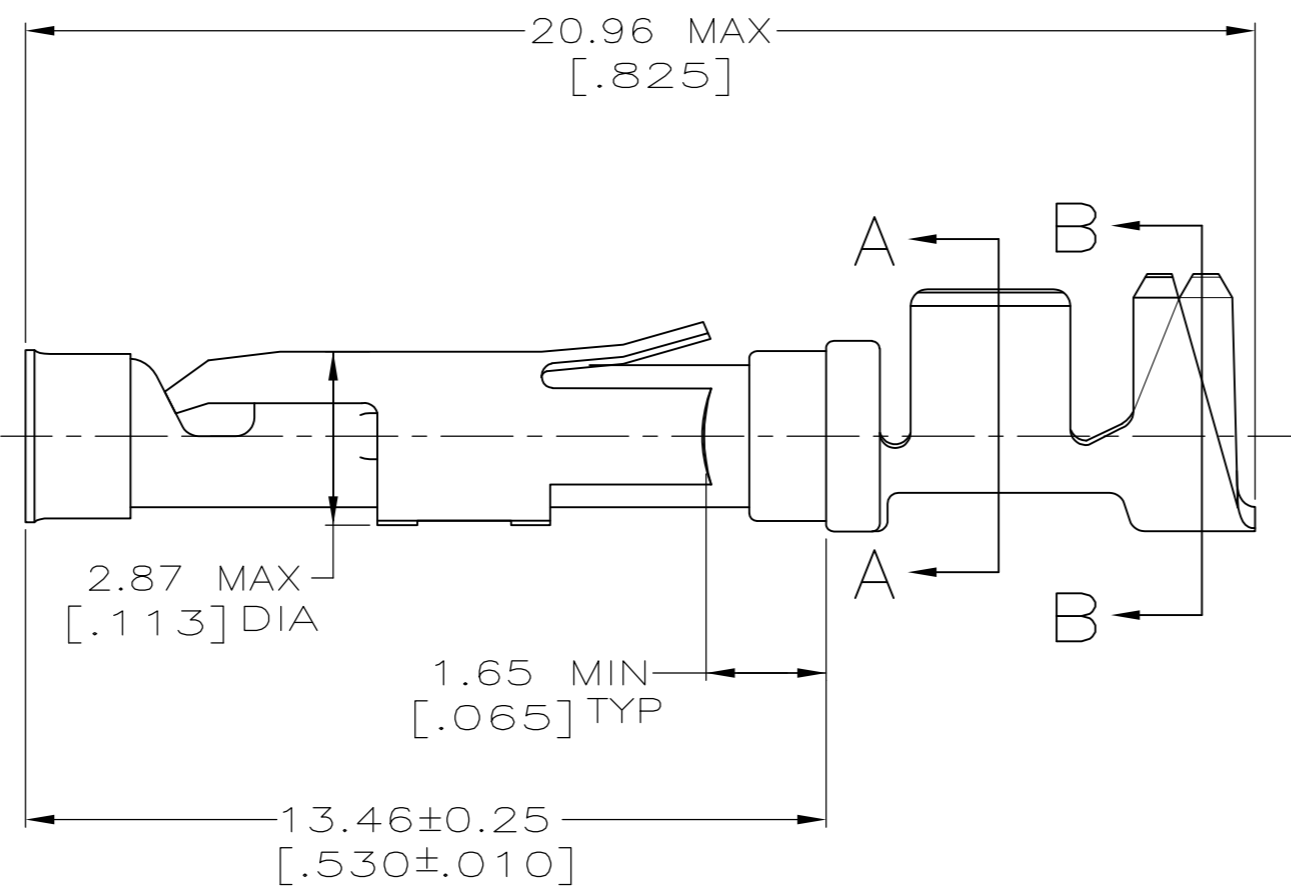
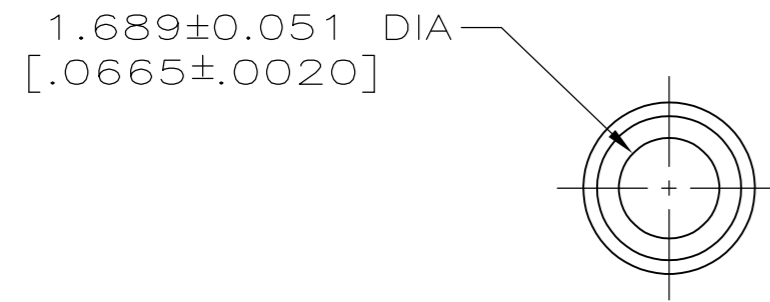
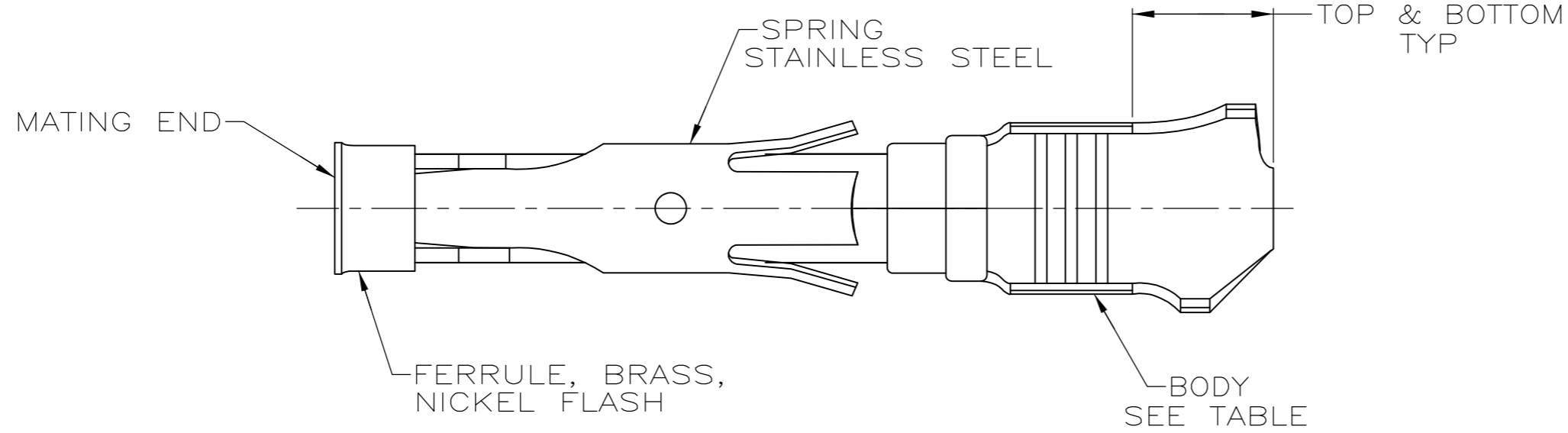

- ① 0.76µm [.000030] MIN GOLD PER MIL-G-45204 ON MATING END FOR A LENGTH OF 5.08 [.200] MIN WITH GOLD FLASH ON THE REMAINDER OVER 0.76µm [.000030] MIN NICKEL PER QQ-N-290.
- ② 1.27µm [.000050] MIN TIN-LEAD PER MIL-T-10727 OVER 0.76µm [.000030] MIN NICKEL PER QQ-N-290.
- ③ BRASS PER MIL-C-50.
- ④ PHOSPHOR BRONZE PER QQ-P-750.
- ⑤ GOLD PLATING NEED NOT APPEAR IN THIS AREA.
- ⑥ WIRE RANGE 14-18 AWG. INSULATION RANGE 2.79[.110]-3.81[.150].
- ⑦ 0.38µm [.000015] MIN GOLD PER MIL-G-45204 ON MATING END FOR A LENGTH OF 5.08 [.200] MIN, 1.27µm [.000050] MIN TIN-LEAD PER MIL-T-10727 FOR A LENGTH OF 5.69 [.224] MIN ON OPPOSITE END, BOTH OVER 1.27µm [.000050] MIN NICKEL PER QQ-N-290 ON ENTIRE CONTACT.
- ⑧ 1.27µm [.000050] MIN TIN PER MIL-T-10727 OVER 0.76µm [.000030] MIN NICKEL PER QQ-N-290.
- ⑨ CU-NI ALLOY

⑩ 0.76µm [.000030] MIN GOLD PER MIL-G-45204 ON MATING END FOR A LENGTH OF 5.08 [.200] MIN WITH 1.27µm [.000050] MIN MATTE TIN PLATE IN WIRE CRIMP AREA, BOTH OVER 0.76µm [.000030] MIN NICKEL PER QQ-N-290.

PACKAGING	BODY FINISH	BODY MATERIAL	STRIP P/N REF	PART NO.
SMALL PACK	⑧	③	66598-9	1-66601-3
STANDARD	⑧	⑨	1-66598-2	1-66601-2
STANDARD	①	⑨	1-66598-1	1-66601-0
STANDARD	⑧	③	66598-9	66601-9
SMALL PACK	⑩	③	66598-2	66601-8
SMALL PACK	②	③	66598-1	66601-7
OBSOLETE	⑦	③	66598-8	66601-5
OBSOLETE	①	④	66598-6	66601-4
OBSOLETE	②	④	66598-5	66601-3
STANDARD	⑩	③	66598-2	66601-2
STANDARD	②	③	66598-1	66601-1

THIS DRAWING IS A CONTROLLED DOCUMENT.		DWN R.SHIREY 7-31-91		
DIMENSIONS: mm [INCHES]		CHK R.STONE 9-20-91		
TOLERANCES UNLESS OTHERWISE SPECIFIED:		APVD J.WESTMAN 9-20-91	NAME SOCKET ASSEMBLY, LOOSE PIECE, TYPE III+	
0 PLC ± - 1 PLC ± - 2 PLC ± 0.13[.005] 3 PLC ± - 4 PLC ± - ANGLES ± -		PRODUCT SPEC -	SIZE A2 CAGE CODE 00779 DRAWING NO C-66601	
MATERIAL SEE CALLOUTS		FINISH SEE CALLOUTS	RESTRICTED TO -	
CUSTOMER DRAWING		WEIGHT -	SCALE 8:1 SHEET 1 OF 1 REV V	