

| PART NUMBER | REVISION | DESCRIPTION | FEED TYPE |
|-------------|----------|----------------------------------|------------|
| 2150469-1 | B | FINE CRIMP HEIGHT ADJUST | MECHANICAL |
| 2150469-2 | B | FINE CRIMP HEIGHT ADJUST | PNEUMATIC |
| 7-2150469-1 | B | MECHANICAL AND CRIMP TOOLING KIT | MECHANICAL |
| 7-2150469-2 | B | PNEUMATIC AND CRIMP TOOLING KIT | PNEUMATIC |
| 7-2150469-7 | A | CRIMP TOOLING KIT | - |

ATLANTIC VERSION TERMINATOR INTERFACE ADAPTER

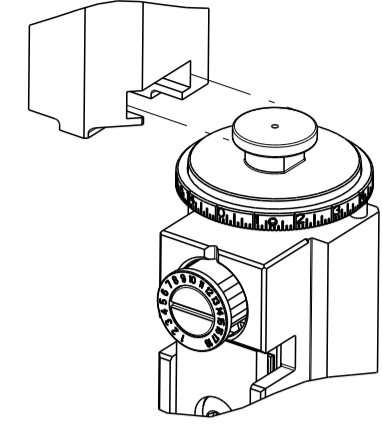

| APPLICATOR DATA | | |
|-----------------|----------------|------|
| CRIMP | SIZE | TYPE |
| WIRE | 2.79 mm [.110] | F |
| INSUL | 3.56 mm [.140] | F |

APPLICATOR INSTRUCTIONS 408-35043

| TERMINAL DATA: G&H(LEAR) TERMINAL TE CRIMP SPECIFICATION | | | |
|--|---------------------------|-------------|--------------------|
| TERMINAL NAME: TERMINAL | | | |
| WIRE STRIP LENGTH | INSULATION DIAMETER RANGE | | |
| 5.46-6.22 mm [.215-.245 IN] | ∅ 3.05 mm [.120 IN] MAX | | |
| TERMINAL APPLICATION SPECIFICATION | NONE | - | - |
| TERMINALS APPLIED | | | |
| TE TERMINAL | G&H(LEAR) TERMINAL | TE TERMINAL | G&H(LEAR) TERMINAL |
| 2113559-1 | 28110.201.042 | 2113559-5 | 28110.201.004 |
| 2113559-2 | 28110.123.242 | 2113559-6 | 28110.123.211 |
| 2113559-3 | 28110.417.031 | 2113559-7 | 28110.123.204 |
| 2113559-4 | 28110.201.011 | | |

| WIRE SIZE | CRIMP HEIGHT mm [INCH] | CRIMP HEIGHT REFERENCE SETTING |
|-----------|----------------------------|--------------------------------|
| 1.50mm2 | 1.70+/-0.05 [.067+/-0.002] | 7.1 |
| 1.00mm2 | 1.55+/-0.05 [.061+/-0.002] | 8.8 |
| 0.75mm2 | 1.48+/-0.05 [.058+/-0.002] | 9.5 |

- 1. RECOMMENDED SPARE PARTS
- 2. REFER TO SUPPLIED INSTRUCTION SHEET FOR CLEANING, LUBRICATION AND STORAGE OF APPLICATOR.
- 3. APPLY PART NUMBER 2-23419-6 LOCTITE TO THREADS OF ITEM 242. APPLY PART NUMBER 1-23419-5 LOCTITE TO THREADS OF ITEM 180.
- 4. CRIMP HEIGHT REFERENCE SETTING WAS THE SETTING USED WHEN THE APPLICATOR WAS QUALIFIED AT THE FACTORY. ADJUSTMENT MAY BE NECESSARY WHEN RUNNING APPLICATOR IN THE FIELD.
- 5. TERMINAL LUBRICANT IS RECOMMENDED.
- 6. UNLESS SPECIFIED OTHERWISE TORQUE VALUES SHALL BE USED PER DOCUMENT, 101-35000.

***WARNING**
ON INSTALLATION, SET WIRE DISC TO CRIMP HEIGHT REFERENCE SETTING FOR LARGEST WIRE SIZE. CRIMP HEIGHT REFERENCE SETTINGS GREATER THAN THE VALUE SHOWN MAY CAUSE DAMAGE TO THE CRIMP TOOLING. REFER TO THE INSTRUCTION SHEET FOR PROPER SETUP AND ADJUSTMENTS.

ATLANTIC VERSION
Shown on sheets 1 of 4 & 2 of 4
(Pacific version shown on sheets 3 of 4 & 4 of 4)

| LOC | DIST | REVISIONS | | | | | |
|-----|------|-----------|-----|---------------|-----------|-----|------|
| | | P | LTN | DESCRIPTION | DATE | DWN | APVD |
| A | 66 | A | | RELEASED | 22OCT2014 | KH | UG |
| | | B | | ECR-21-006980 | 21JUL2021 | TB | RK |

| | | | | | | | | |
|---|-----|-----|-----|-----|-------------|-------------------------------------|-------------|---------|
| - | 1 | - | 1 | - | 2119641-1 | FEED CAM, AIR FEED | 248 | |
| - | 1 | 1 | 1 | 1 | 2119082-3 | CAM, SNAIL, INSULATION ADJUSTMENT | 244 | |
| - | 1 | 1 | 1 | 1 | 2079764-1 | WASHER, WAVE SPRING, CREST-TO-CREST | 243 | |
| 3 | - | 1 | 1 | 1 | 2119083-1 | RETAINER, INSULATION DIAL | 242 | |
| - | - | 1 | - | 1 | 2119580-1 | MECHANICAL FEED ASSEMBLY | 239 | |
| - | 1 | - | 1 | - | 2844940-3 | AIR FEED MODULE | 238 | |
| - | 1 | 1 | 1 | 1 | 1-18028-0 | WASHER, FLAT, REG M8 | 192 | |
| 3 | - | 1 | 1 | 1 | 1-1976055-3 | STANDOFF, HOLD-DOWN | 180 | |
| - | 1 | 1 | 1 | 1 | 6-993111-6 | PIN, SLOTTED SPRING 3.0 X 14.0 | 177 | |
| - | 1 | 1 | 1 | 1 | 8-22280-7 | SPRING, COMPRESSION | 176 | |
| - | 1 | 1 | 1 | 1 | 1752353-2 | GUIDE PIN,HOLDDOWN | 175 | |
| - | 1 | 1 | 1 | 1 | 1901680-2 | GUIDE PIN,HOLDDOWN | 174 | |
| - | REF | REF | REF | REF | 994970-2 | COUNTER, MAGNETIC | 164 | |
| - | 1 | 1 | 1 | 1 | 455888-4 | SPACER, CRIMPER | 82 | |
| - | 1 | 1 | 1 | 1 | 1803607-4 | DOCUMENTATION PACKAGE | 71 | |
| - | 2 | 2 | 2 | 2 | 2-18032-2 | SCR, SET, FLT PNT, M3 X 10.0 | 70 | |
| - | 1 | 1 | 1 | 1 | 2119740-1 | TAG, IDENTIFICATION | 67 | |
| - | 2 | 2 | 2 | 2 | 2168078-1 | SCREW, DRIVE, RH, RoHS, 2 x .188 | 66 | |
| - | 1 | 1 | 1 | 1 | 1901681-5 | HOLDDOWN, TERMINAL | 65 | |
| - | 2 | 2 | 2 | 2 | 2168400-5 | SHCS, LOW HEAD, RoHS, M4 X 20 | 64 | |
| - | 1 | 1 | 1 | 1 | 2168083-2 | SCR, SKT HD CAP, RoHS, M4 X 8.0 | 60 | |
| - | 1 | 1 | 1 | 1 | 5-18022-5 | SCR, HEX HD CAP, M4 X 6.0 | 59 | |
| - | - | 1 | - | 1 | 2063961-1 | FEED FINGER | 58 | |
| - | 3 | 3 | 3 | 3 | 2168400-4 | SHCS, LOW HEAD, RoHS, M4 X 8 | 57 | |
| - | 2 | 2 | 2 | 2 | 1-2168083-0 | SCR, SKT HD CAP, RoHS, M4 X 10 | 56 | |
| - | 2 | 2 | 2 | 2 | 5018030-1 | NUT, HEX, REG, RoHS, M3 | 54 | |
| - | 2 | 2 | 2 | 2 | 986965-8 | NUT, LOCK, HEX, TORQUE (M4) | 53 | |
| - | 1 | 1 | 1 | 1 | 1-5018030-0 | NUT, HEX, REG, RoHS, M3.5 | 52 | |
| - | 1 | - | 1 | - | 2063961-1 | FEED FINGER | 51 | |
| - | 1 | 2 | 1 | 2 | 18023-9 | SCR, SKT HD CAP M4 X 6.0 | 49 | |
| - | - | 1 | - | 1 | 2119652-1 | FEED CAM, PRE FEED | 48 | |
| - | - | 1 | - | 1 | 2119653-1 | FEED CAM, POST FEED | 47 | |
| - | 1 | 1 | 1 | 1 | 2119655-5 | APPLICATOR BASIC ASSEMBLY, EF | 46 | |
| - | 1 | 1 | 1 | 1 | 1803517-1 | RAM ASSEMBLY, EF ATLANTIC | 44 | |
| - | 1 | 1 | 1 | 1 | 1803602-1 | SCR, BHSC, RoHS (M8 X 25) | 41 | |
| - | 7 | 7 | 7 | 7 | 1-18028-2 | WASHER, FLAT, REG M4 | 33 | |
| - | 2 | 2 | 2 | 2 | 2168083-9 | SCR, SKT HD CAP, RoHS, M4 X 20 | 31 | |
| - | 2 | 2 | 2 | 2 | 2168083-2 | SCR, SKT HD CAP, RoHS, M4 X 8.0 | 29 | |
| - | 1 | 1 | 1 | 1 | 240639-1 | STRIPPER (MACHINING) | 27 | |
| - | 2 | 2 | 2 | 2 | 1-2168083-5 | SCR, SKT HD CAP, RoHS, M4 X 30 | 25 | |
| - | 1 | 1 | 1 | 1 | 1-1752371-2 | PLATE, STRIP GUIDE | 24 | |
| - | 1 | 1 | 1 | 1 | 240825-4 | PLATE, STRIP HOLD DOWN | 23 | |
| - | 2 | 2 | 2 | 2 | 2-22281-3 | SPRING, COMPRESSION | 22 | |
| - | 1 | 1 | 1 | 1 | 1803292-4 | DRAG | 20 | |
| - | 2 | 2 | 2 | 2 | 1901259-6 | GUIDE, LOWER STRIP | 18 | |
| - | 4 | 4 | 4 | 4 | 1-2079383-1 | SCR, BHSC, RoHS (M6 X 12) | 17 | |
| - | 1 | 1 | 1 | 1 | 240641-8 | SPACER | 16 | |
| - | 1 | 1 | 1 | 1 | 1752360-1 | SPACER,HOLD-DOWN | 13 | |
| 1 | - | 1 | 1 | 1 | 240644-9 | PLATE, REAR SHEAR | 11 | |
| - | - | - | - | - | - | - | 10 | |
| 1 | - | 1 | 1 | 1 | 690495-4 | PLATE, FRONT SHEAR | 9 | |
| 1 | 1 | 2 | 2 | 1 | 1-1803060-3 | ANVIL, COMBINATION, END FEED | 8 | |
| 1 | - | 1 | 1 | 1 | 1-2217206-3 | BLADE, SLUG | 7 | |
| - | - | - | - | - | - | - | 6 | |
| - | 1 | 1 | 1 | 1 | 3-240641-7 | SPACER | 5 | |
| - | 1 | 1 | 1 | 1 | 238011-2 | BLOCK, CRIMPER SPACER | 4 | |
| 1 | 1 | 2 | 2 | 1 | 2-1633961-3 | CRIMPER, INSULATION F PREMIUM | 3 | |
| - | 1 | 1 | 1 | 1 | 455888-8 | SPACER, CRIMPER | 2 | |
| 1 | 1 | 2 | 2 | 1 | 1-456408-9 | CRIMPER, WIRE PREMIUM | 1 | |
| - | 77 | 72 | 71 | 2 | -1 | PART NO | DESCRIPTION | ITEM NO |

| DIMENSIONS: | | TOLERANCES UNLESS OTHERWISE SPECIFIED: | | DRAWING NO | | RESTRICTED TO | |
|--|---------|--|---------|------------|---------|---------------|----------|
| mm | 0 PLC ± | 1 PLC ± | 2 PLC ± | 3 PLC ± | 4 PLC ± | ANGLES ± | FINISH ± |
| MATERIAL | | | | WEIGHT | SCALE | SHEET | REV |
| Customer Accessible Production Drawing | | | | 00779 | 1:1 | 1 of 4 | B |

| LOC | | DIST | | REVISIONS | | | |
|-----|----|------|-----|-------------|------|-----|------|
| A | 66 | P | LTM | DESCRIPTION | DATE | OWN | APVD |
| | | - | | SEE SHEET 1 | | | |

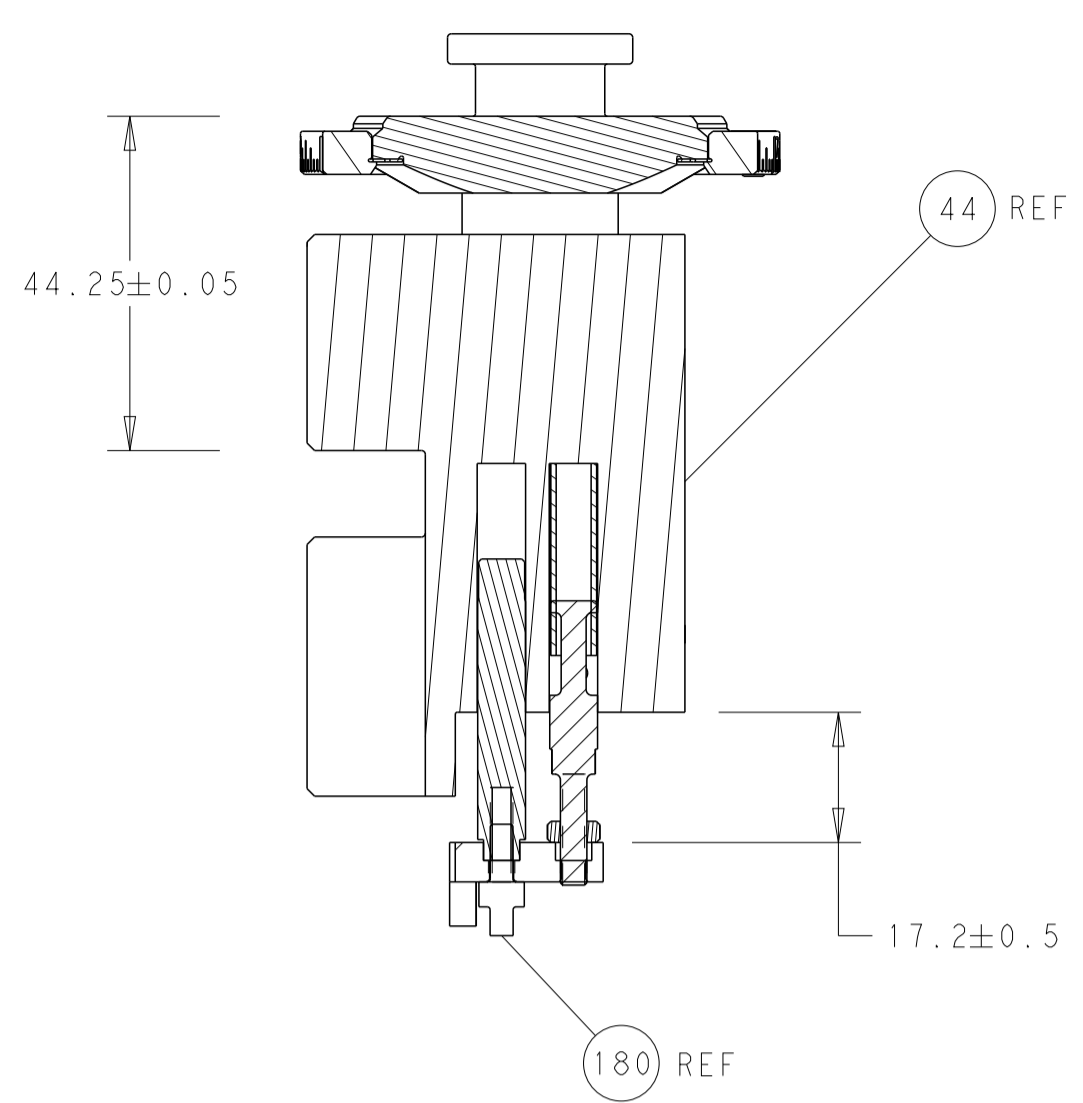

RAM AND HOLDDOWN SET-UP

FEED TYPE
MECHANICAL

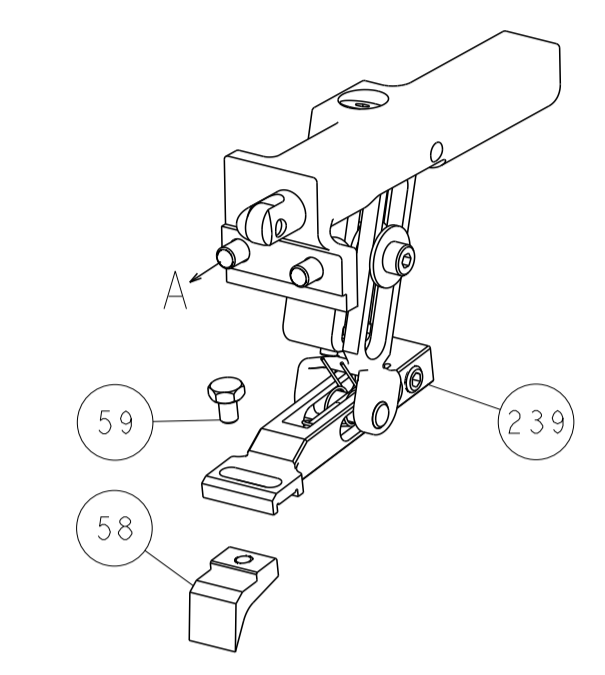

PNEUMATIC

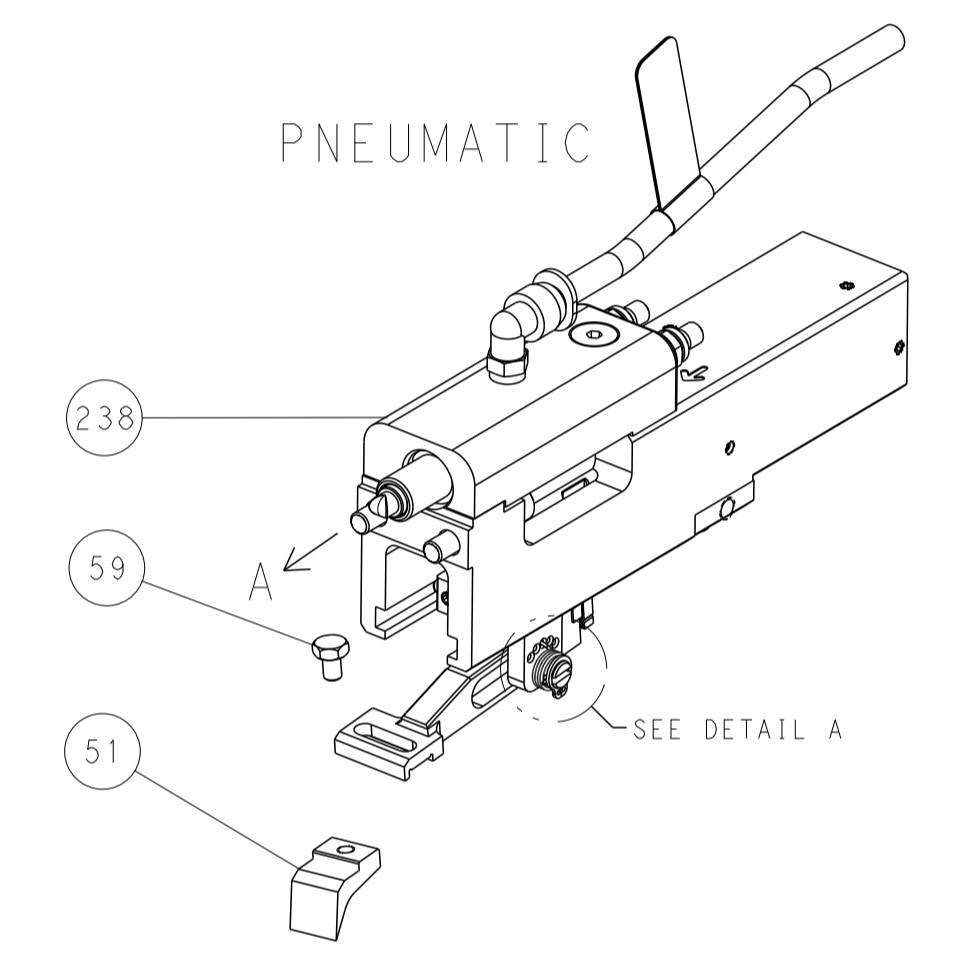

FEED SPRING
SETTING POSITION

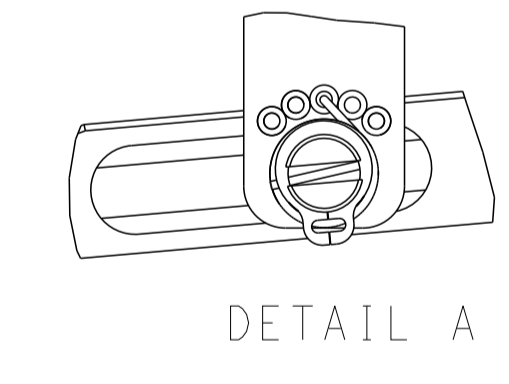

DETAIL A

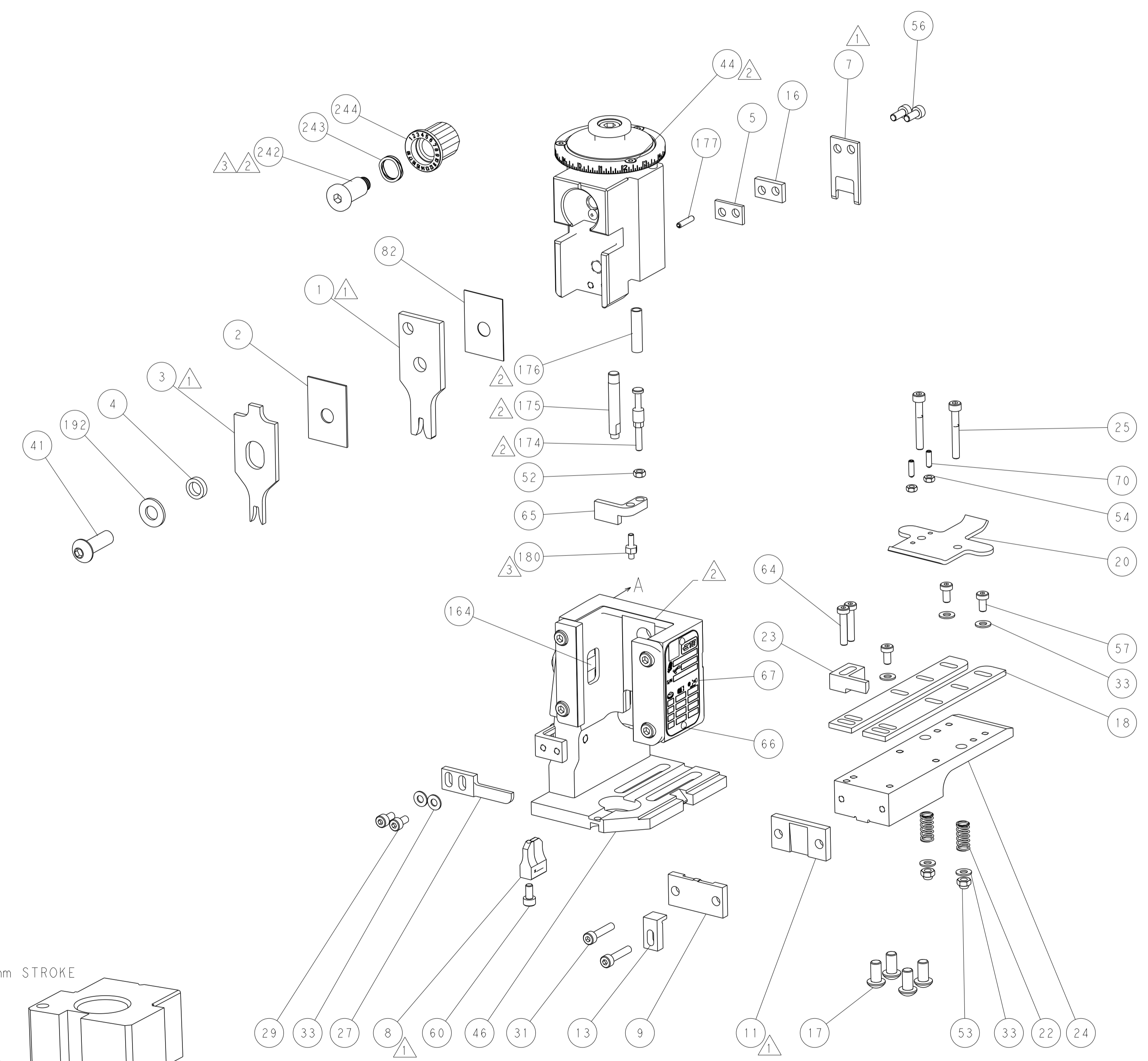

CAM POSITIONS

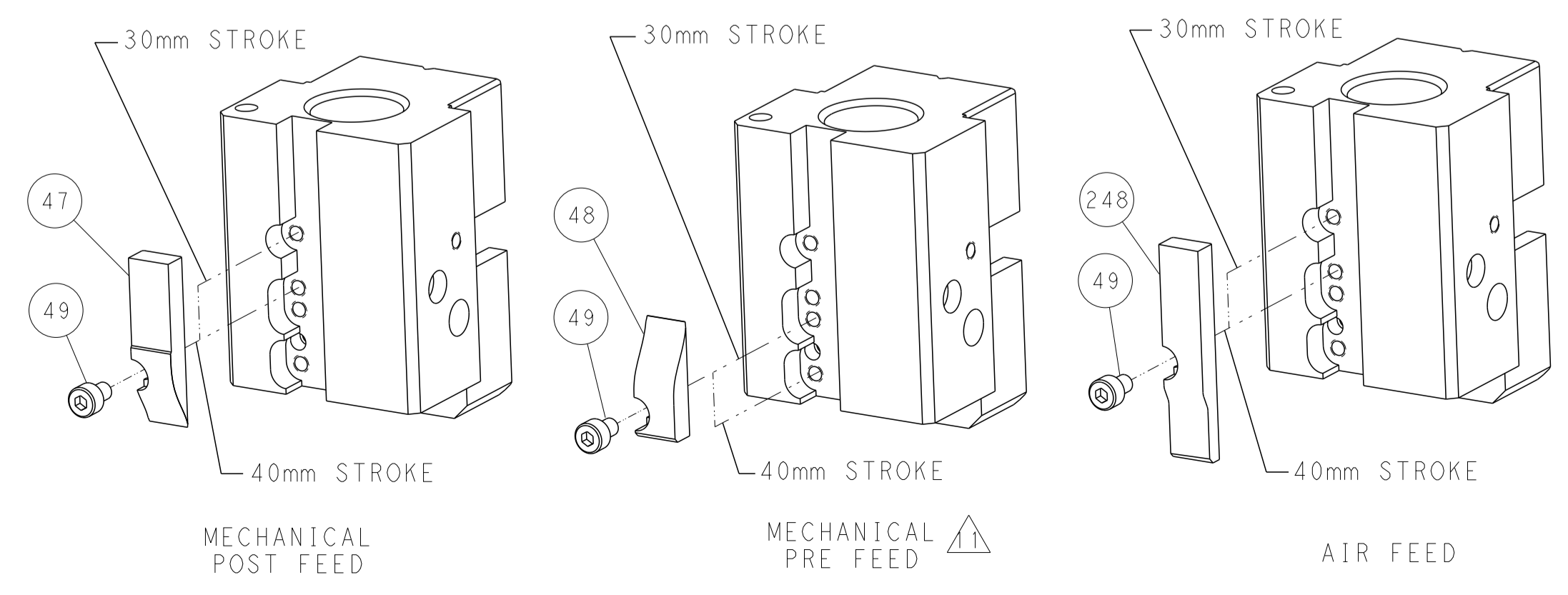

ATLANTIC VERSION
 Shown on sheets 1 of 4 & 2 of 4
 (Pacific version shown on sheets 3 of 4 & 4 of 4)

| | | | | | | | |
|---|--|---|--|---|--|--|--|
| DIMENSIONS: mm | | TOLERANCES UNLESS OTHERWISE SPECIFIED: 0 PLC ± 1 PLC ± 2 PLC ± 3 PLC ± 4 PLC ± ANGLES ± FINISH | | DWN K. HUANG 15AUG2014 CHK L. ZHANG 15AUG2014 APVD H. GUO 15AUG2014 PRODUCT SPEC APPLICATION SPEC WEIGHT Customer Accessible Production Drawing | | NAME Ocean End Feed Applicator SIZE CAGE CODE DRAWING NO. RESTRICTED TO A1 00779 ©=2150469 SCALE 1:1 SHEET 2 OF 4 REV B | |
| THIS DRAWING IS UNPUBLISHED. RELEASED FOR PUBLICATION BY TYCO ELECTRONICS CORPORATION. ALL RIGHTS RESERVED. | | | | TE Connectivity Harrisburg, PA 17105-3608 | | | |

| PART NUMBER | REVISION | DESCRIPTION | FEED TYPE |
|-------------|----------|--------------------------|------------|
| 2-2150469-1 | B | FINE CRIMP HEIGHT ADJUST | MECHANICAL |
| 2-2150469-2 | B | FINE CRIMP HEIGHT ADJUST | PNEUMATIC |
| 7-2150469-7 | A | CRIMP TOOLING KIT | - |

PACIFIC VERSION TERMINATOR
INTERFACE ADAPTER

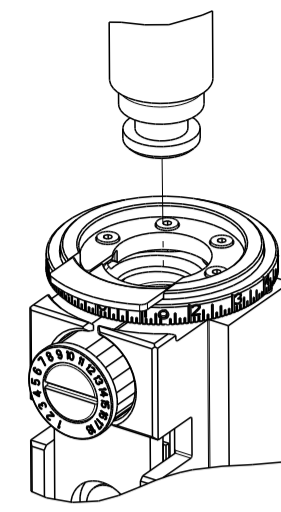

| APPLICATOR DATA | | |
|--------------------------------------|----------------|------|
| CRIMP | SIZE | TYPE |
| WIRE | 2.79 mm (.110) | F |
| INSUL | 3.56 mm (.140) | F |
| APPLICATOR INSTRUCTIONS 408-35043 | | |

| TERMINAL DATA: G&H(LEAR) TERMINAL TE CRIMP SPECIFICATION | | | |
|--|---------------------------|-------------|--------------------|
| TERMINAL NAME: TERMINAL | | | |
| WIRE STRIP LENGTH | INSULATION DIAMETER RANGE | | |
| 5.46-6.22 mm (.215-.245 IN) | 3.05 mm (.120 IN) MAX | | |
| TERMINAL APPLICATION SPECIFICATION | NONE | - | - |
| TERMINALS APPLIED | | | |
| TE TERMINAL | G&H(LEAR) TERMINAL | TE TERMINAL | G&H(LEAR) TERMINAL |
| 2113559-1 | 28110.201.042 | 2113559-5 | 28110.201.004 |
| 2113559-2 | 28110.123.242 | 2113559-6 | 28110.123.211 |
| 2113559-3 | 28110.417.031 | 2113559-7 | 28110.123.204 |
| 2113559-4 | 28110.201.011 | | |

| WIRE SIZE | CRIMP HEIGHT mm [INCH] | CRIMP HEIGHT REFERENCE SETTING |
|-----------|-------------------------------|--------------------------------|
| 1.50mm2 | 1.70 +/- 0.05 [.067 +/- .002] | 7.1 |
| 1.00mm2 | 1.55 +/- 0.05 [.061 +/- .002] | 8.8 |
| 0.75mm2 | 1.48 +/- 0.05 [.058 +/- .002] | 9.5 |

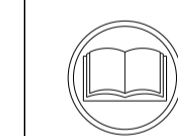

- 1 RECOMMENDED SPARE PARTS
- 2 REFER TO SUPPLIED INSTRUCTION SHEET FOR CLEANING, LUBRICATION AND STORAGE OF APPLICATOR.
- 3 APPLY PART NUMBER 2-23419-6 LOCTITE TO THREADS OF ITEM 242. APPLY PART NUMBER 1-23419-5 LOCTITE TO THREADS OF ITEM 180.
- 4 CRIMP HEIGHT REFERENCE SETTING WAS THE SETTING USED WHEN THE APPLICATOR WAS QUALIFIED AT THE FACTORY. ADJUSTMENT MAY BE NECESSARY WHEN RUNNING APPLICATOR IN THE FIELD.
- 5 TERMINAL LUBRICANT IS RECOMMENDED.
- 6. UNLESS SPECIFIED OTHERWISE TORQUE VALUES SHALL BE USED PER DOCUMENT, 101-35000.

***WARNING**
ON INSTALLATION, SET WIRE DISC TO CRIMP HEIGHT REFERENCE SETTING FOR LARGEST WIRE SIZE. CRIMP HEIGHT REFERENCE SETTINGS GREATER THAN THE VALUE SHOWN MAY CAUSE DAMAGE TO THE CRIMP TOOLING. REFER TO THE INSTRUCTION SHEET FOR PROPER SETUP AND ADJUSTMENTS.

PACIFIC VERSION
Shown on sheets 3 of 4 & 4 of 4
(Atlantic version shown on sheets 1 of 4 & 2 of 4)

| LOC | DIST | REVISIONS | | | | | |
|-----|------|-----------|-----|-------------|------|-----|------|
| A | 66 | P | LTN | DESCRIPTION | DATE | OWN | APVD |
| - | - | - | - | SEE SHEET 1 | - | - | - |

| | | | | | | |
|---|-----|-----|-------------|-------------------------------------|-------------|---------|
| - | 1 | 1 | 2119082-3 | CAM, SNAIL, INSULATION ADJUSTMENT | 244 | |
| - | 1 | 1 | 2079764-1 | WASHER, WAVE SPRING, CREST-TO-CREST | 243 | |
| 3 | - | 1 | 2119083-1 | RETAINER, INSULATION DIAL | 242 | |
| - | - | 1 | 2119580-1 | MECHANICAL FEED ASSEMBLY | 239 | |
| - | 1 | - | 2844940-3 | AIR FEED MODULE | 238 | |
| - | 1 | 1 | 1-18028-0 | WASHER, FLAT, REG M8 | 192 | |
| - | 4 | 4 | 2079383-9 | SCR, BHSC, RoHS (M6 X 20) | 186 | |
| 3 | - | 1 | 1-1976055-3 | STANDOFF, HOLD-DOWN | 180 | |
| - | 1 | 1 | 6-993111-6 | PIN, SLOTTED SPRING 3.0 X 14.0 | 177 | |
| - | 1 | 1 | 8-22280-7 | SPRING, COMPRESSION | 176 | |
| - | 1 | 1 | 1752353-2 | GUIDE PIN, HOLDDOWN | 175 | |
| - | 1 | 1 | 1901680-2 | GUIDE PIN, HOLDDOWN | 174 | |
| - | REF | REF | 994970-2 | COUNTER, MAGNETIC | 164 | |
| - | 1 | - | 2119641-2 | FEED CAM, AIR FEED | 152 | |
| - | 1 | 1 | 2168083-8 | SCR, SKT HD CAP, RoHS, M4 X 16 | 144 | |
| - | - | 1 | 2119653-2 | FEED CAM, POST FEED | 142 | |
| - | 1 | 1 | 2119655-6 | APPLICATOR BASIC ASSEMBLY, EF | 141 | |
| - | 1 | 1 | 1803518-1 | RAM ASSEMBLY, EF PACIFIC | 140 | |
| - | 1 | 1 | 455888-4 | SPACER, CRIMPER | 82 | |
| - | 1 | 1 | 1803607-4 | DOCUMENTATION PACKAGE | 71 | |
| - | 2 | 2 | 2-18032-2 | SCR, SET, FLT PNT, M3 X 10.0 | 70 | |
| - | 1 | 1 | 2119740-1 | TAG, IDENTIFICATION | 67 | |
| - | 2 | 2 | 2168078-1 | SCREW, DRIVE, RH, RoHS, 2 x .188 | 66 | |
| - | 1 | 1 | 1901681-5 | HOLDDOWN, TERMINAL | 65 | |
| - | 2 | 2 | 2168400-5 | SHCS, LOW HEAD, RoHS, M4 X 20 | 64 | |
| - | 1 | 1 | 5-18022-5 | SCR, HEX HD CAP, M4 X 6.0 | 59 | |
| - | - | 1 | 2063961-1 | FEED FINGER | 58 | |
| - | 3 | 3 | 2168400-4 | SHCS, LOW HEAD, RoHS, M4 X 8 | 57 | |
| - | 2 | 2 | 1-2168083-0 | SCR, SKT HD CAP, RoHS, M4 X 10 | 56 | |
| - | 2 | 2 | 5018030-1 | NUT, HEX, REG, RoHS, M3 | 54 | |
| - | 2 | 2 | 986965-8 | NUT, LOCK, HEX, TORQUE (M4) | 53 | |
| - | 1 | 1 | 1-5018030-0 | NUT, HEX, REG, RoHS, M3.5 | 52 | |
| - | 1 | - | 2063961-1 | FEED FINGER | 51 | |
| - | 1 | 2 | 18023-9 | SCR, SKT HD CAP M4 X 6.0 | 49 | |
| - | - | 1 | 2119652-1 | FEED CAM, PRE FEED | 48 | |
| - | 1 | 1 | 1803602-1 | SCR, BHSC, RoHS (M8 X 25) | 41 | |
| - | 7 | 7 | 1-18028-2 | WASHER, FLAT, REG M4 | 33 | |
| - | 2 | 2 | 2168083-9 | SCR, SKT HD CAP, RoHS, M4 X 20 | 31 | |
| - | 2 | 2 | 2168083-2 | SCR, SKT HD CAP, RoHS, M4 X 8.0 | 29 | |
| - | 1 | 1 | 240639-1 | STRIPPER (MACHINING) | 27 | |
| - | 2 | 2 | 1-2168083-5 | SCR, SKT HD CAP, RoHS, M4 X 30 | 25 | |
| - | 1 | 1 | 1-1752371-2 | PLATE, STRIP GUIDE | 24 | |
| - | 1 | 1 | 240825-4 | PLATE, STRIP HOLD DOWN | 23 | |
| - | 2 | 2 | 2-22281-3 | SPRING, COMPRESSION | 22 | |
| - | 1 | 1 | 1803292-4 | DRAG | 20 | |
| - | 2 | 2 | 1901259-6 | GUIDE, LOWER STRIP | 18 | |
| - | 1 | 1 | 240641-8 | SPACER | 16 | |
| - | 1 | 1 | 1752360-1 | SPACER, HOLD-DOWN | 13 | |
| 1 | - | 1 | 240644-9 | PLATE, REAR SHEAR | 11 | |
| - | - | - | - | - | 10 | |
| - | 1 | 1 | 690495-4 | PLATE, FRONT SHEAR | 9 | |
| 1 | 1 | 1 | 1-1803060-3 | ANVIL, COMBINATION, END FEED | 8 | |
| 1 | - | 1 | 1-2217206-3 | BLADE, SLUG | 7 | |
| - | - | - | - | - | 6 | |
| - | 1 | 1 | 3-240641-7 | SPACER | 5 | |
| - | 1 | 1 | 238011-2 | BLOCK, CRIMPER SPACER | 4 | |
| 1 | 1 | 1 | 2-1633961-3 | CRIMPER, INSULATION F PREMIUM | 3 | |
| - | 1 | 1 | 455888-8 | SPACER, CRIMPER | 2 | |
| 1 | 1 | 1 | 1-456408-9 | CRIMPER, WIRE PREMIUM | 1 | |
| - | 77 | 22 | 21 | PART NO | DESCRIPTION | ITEM NO |

| DIMENSIONS: | | TOLERANCES UNLESS OTHERWISE SPECIFIED: | | DRAWING NO | |
|--|----------|--|---------|--------------------|--------------|
| mm | 0 PLC ± | 1 PLC ± | 2 PLC ± | 3 PLC ± | 4 PLC ± |
| | ANGLES ± | FINISH ± | | | |
| MATERIAL | | FINISH | | WEIGHT | |
| | | | | A1 00779 C=2150469 | |
| Customer Accessible Production Drawing | | | | SCALE | SHEET 3 OF 4 |
| | | | | REV | B |

| LOC | | DIST | | REVISIONS | | | |
|-----|----|------|-----|-------------|------|-----|------|
| A | 66 | P | LTM | DESCRIPTION | DATE | OWN | APVD |
| | | - | | SEE SHEET 1 | | | |

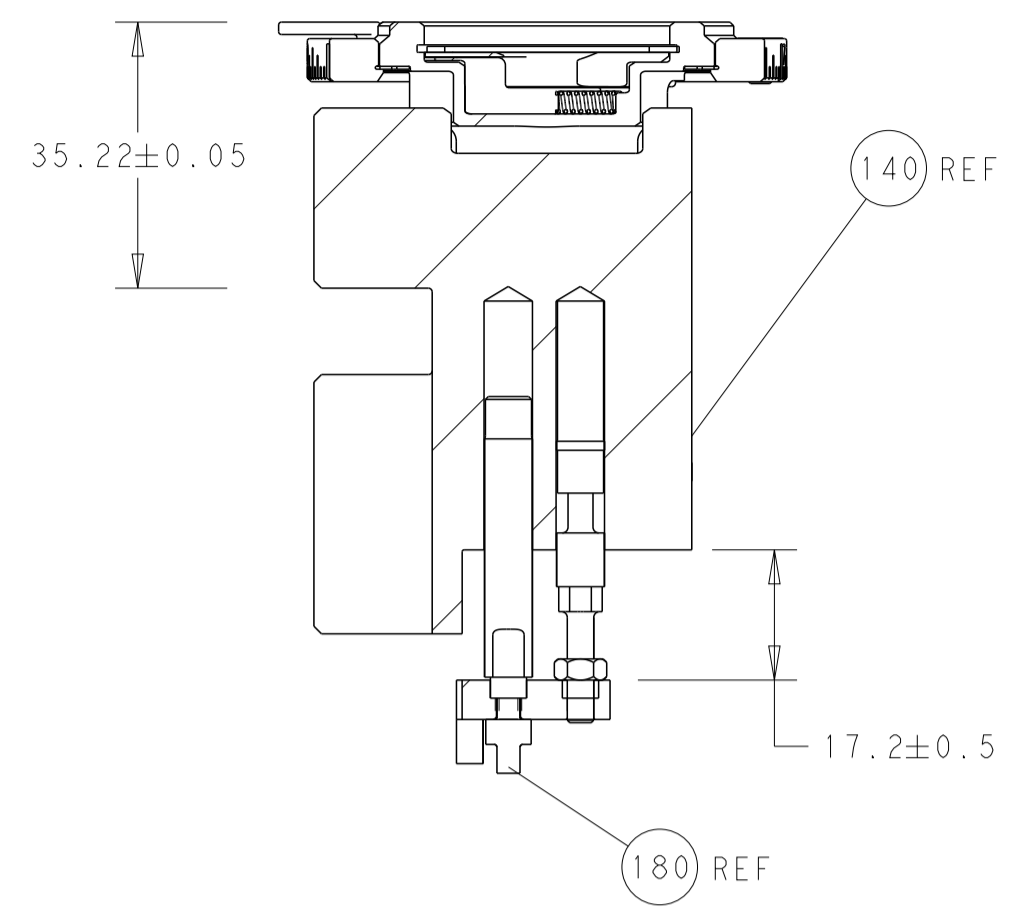

RAM AND HOLDDOWN SET-UP

FEED TYPE
MECHANICAL

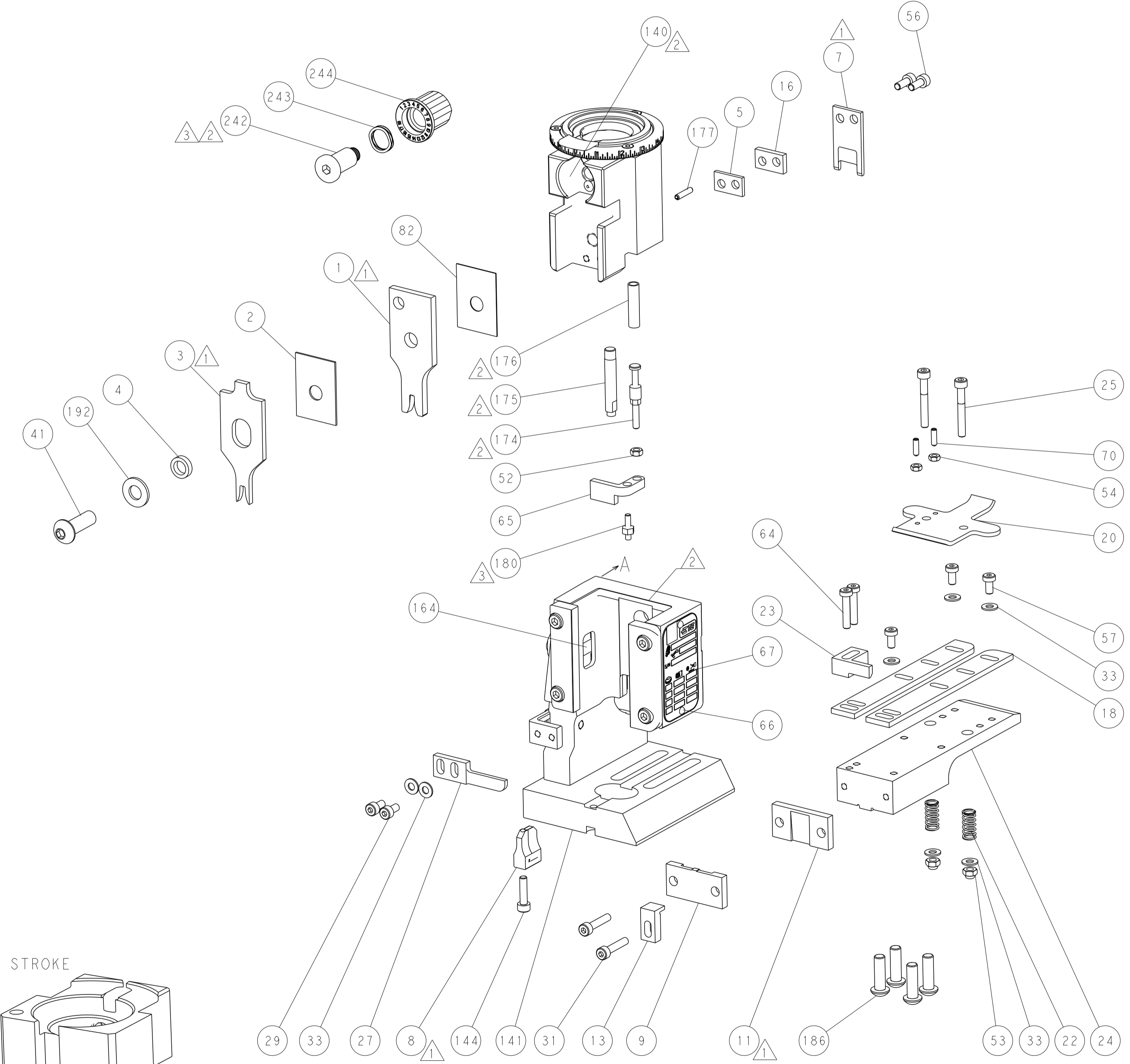
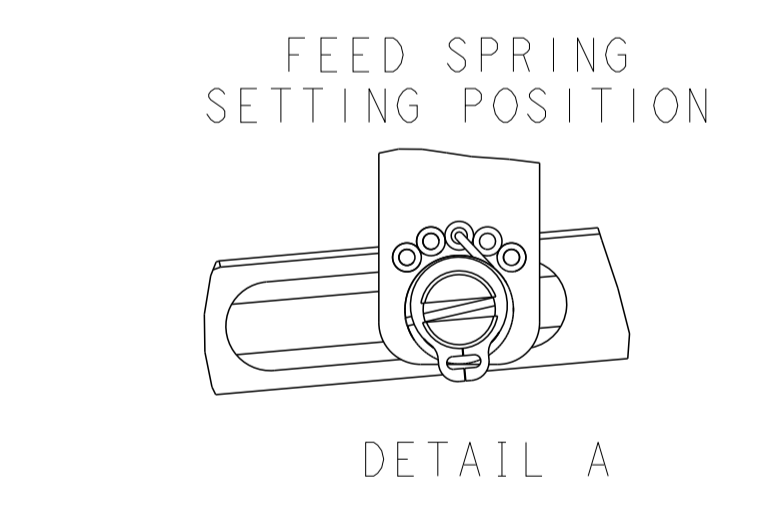
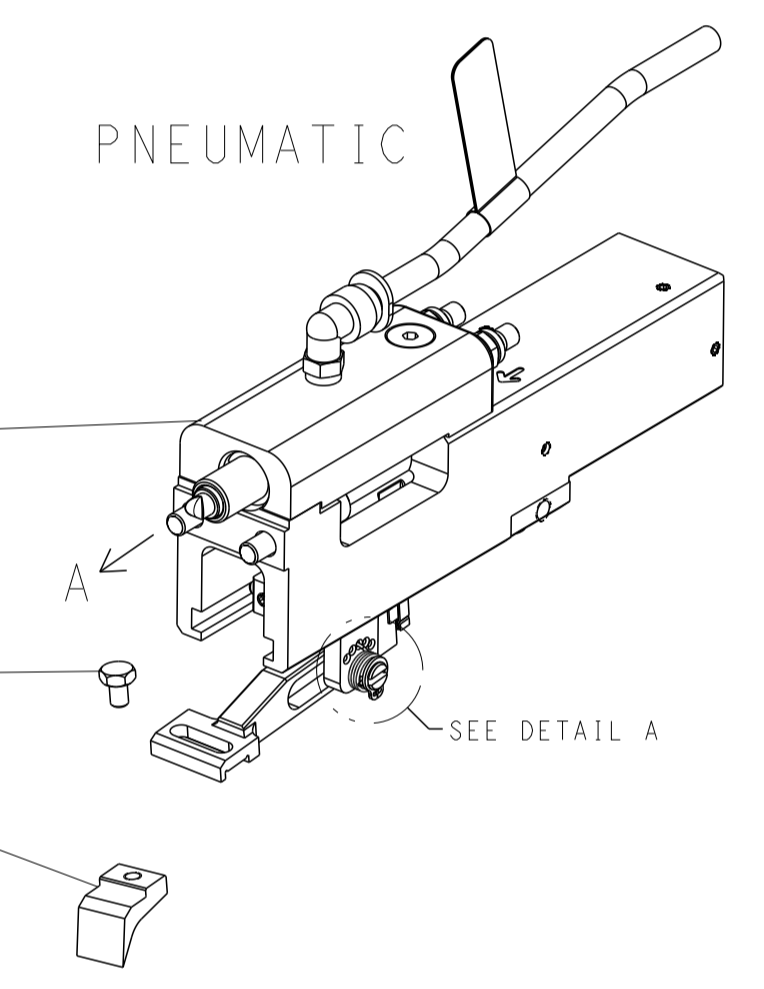
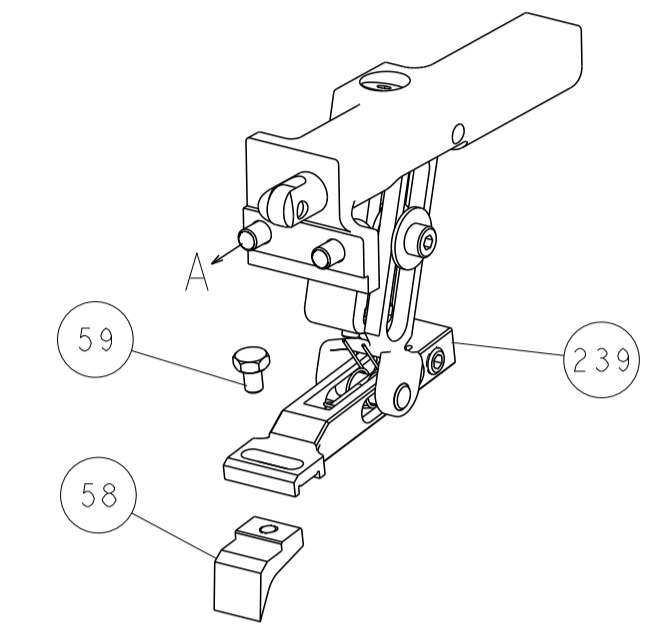

CAM POSITIONS

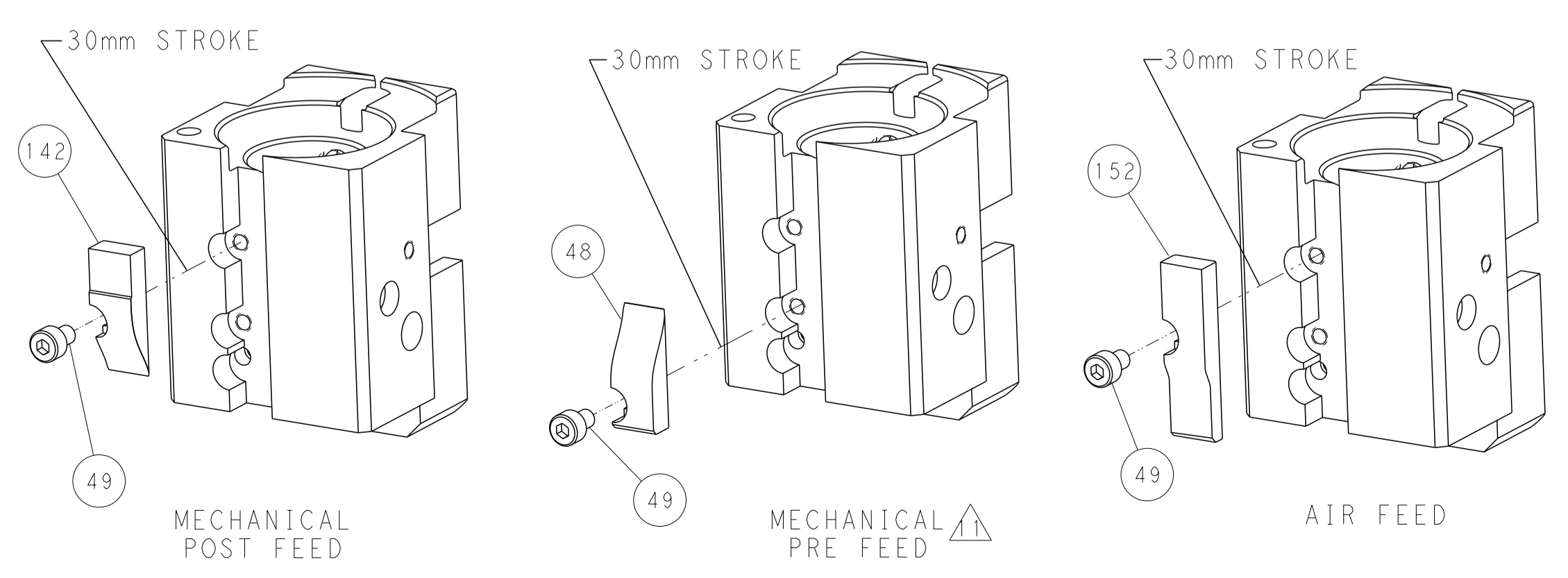

PACIFIC VERSION
 Shown on sheets 3 of 4 & 4 of 4
 (Atlantic version shown on sheets 1 of 4 & 2 of 4)

| | | | | | | | |
|-------------|---------|--|---------|------------------------|------------------------|--|---------------------------|
| DIMENSIONS: | | TOLERANCES UNLESS OTHERWISE SPECIFIED: | | DWN K. HUANG 15AUG2014 | | STE TE Connectivity | |
| mm | 0 PLC ± | 1 PLC ± | 2 PLC ± | 3 PLC ± | 4 PLC ± | NAME | Harrisburg, PA 17105-3608 |
| | ANGLES | FINISH | | CHK L. ZHANG 15AUG2014 | APVD JJ. GUO 15AUG2014 | Customer Accessible Production Drawing | |
| MATERIAL | | | | PRODUCT SPEC | APPLICATION SPEC | SIZE | CAGE CODE |
| | | | | WEIGHT | SCALE | A1 00779 | DRAWING NO |
| | | | | | | ©=2150469 | RESTRICTED TO |
| | | | | | | SCALE 1:1 | SHEET 4 OF 4 REV B |