

REV.	DATE	ECR NO.	DESCRIPTION
NC	08/21/07	-	INITIAL RELEASE
A	10/30/07	-	REVISE SLOT DIMENSION TO 1.65mm (1)
B	11/25/07	-	REVISE SLOT DIMENSION TO 1.75mm [.069] (1)
C	03/16/08	-	REVISE CONTACT PIN DIAMETER TO 1.27mm [.050]
D	04/21/08	-	REMOVE LOCK WASHER AND HEX NUT FROM BOM, BODY PLATING TO GOLD
E	01/26/09	-	REVISE FLANGE/P.C. BOARD SLOT ORIENTATION
F	02/25/09	-	ADD LOCK WASHER AND HEX NUT
G	05/26/09	-	LOCK WASHER WAS GOLD/BRASS; HEX NUT WAS GOLD; CONT WAS PHOS BRONZE

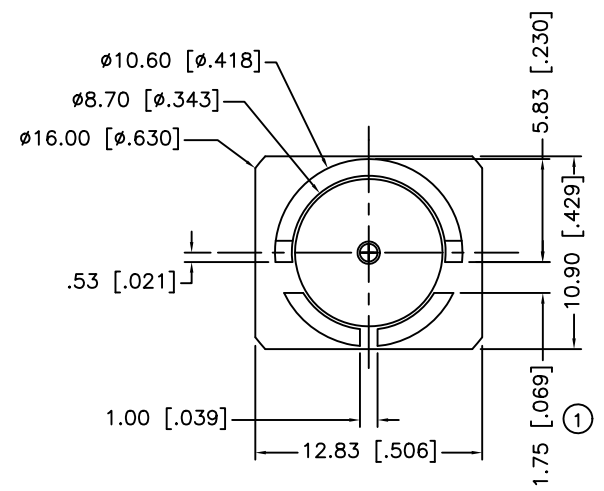
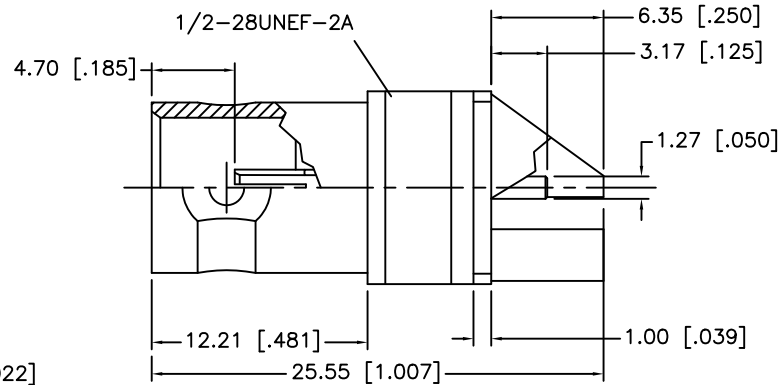
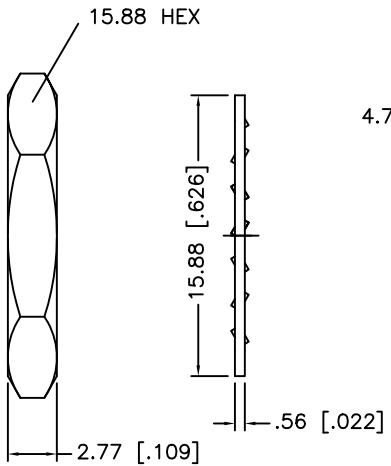
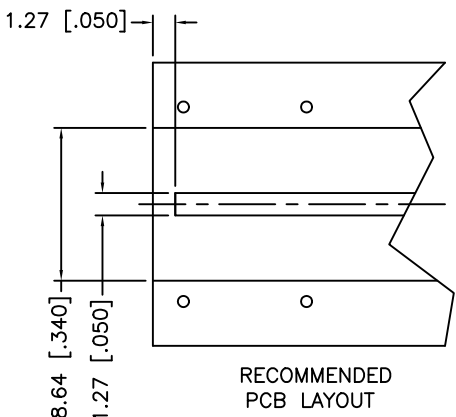
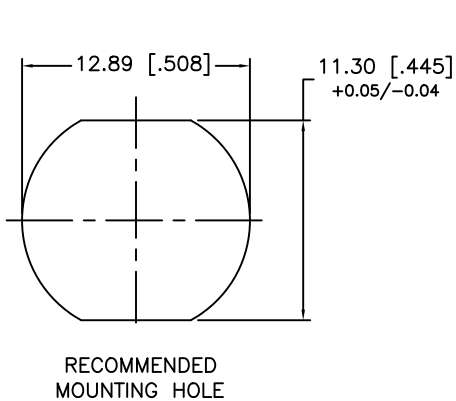

DESCRIPTION	MATERIAL	FINISH	QTY
8			
7			
6			
5	HEX NUT	BRASS	NICKEL 1
4	LOCK WASHER	PHOS. BRONZE	NICKEL 1
3	CONTACT PIN	BeCu	GOLD 1
2	INSULATOR	PTFE	NATURAL 1
1	BODY	BRASS	GOLD 1

UNLESS OTHERWISE SPECIFIED DIMENSIONS ARE IN MILLIMETERS. DIMENSIONS IN [] ARE IN INCHES AND FOR CUSTOMER REFERENCE ONLY.

UNLESS OTHERWISE SPECIFIED TOLERANCES FOR MILLIMETERS ARE:
0.5 - 8mm ± 0.20mm
8 - 30mm ± 0.40mm
30 - 120mm ± 0.50mm

UNLESS OTHERWISE SPECIFIED TOLERANCES FOR INCHES ARE:
.020 - .315 = ± 0.007"
.315 - 1.180 = ± 0.015"
1.180 - 4.724 = ± 0.020"

DO NOT SCALE DRAWING

APPROVALS	DATE
DRAWN G.R.S.	02/25/09
CHECKED	
ISSUED	
SHEET 1 OF 1	
CAD FILE	C:/112/112740.DWG

Amphenol Connex

PART DESCRIPTION
BNC EDGE LAUNCH BULKHEAD JACK, 75 Ohms

PART NO. 112740

DWG. NO.	112740.DWG	REV.	G	SIZE	A	SCALE	NA
----------	------------	------	---	------	---	-------	----