

# PSR-...- 24DC/FSP2/2X1/1X2

SIL  
IEC 61508

## SIL coupling relay



Data sheet  
104509\_en\_02

© PHOENIX CONTACT 2015-05-12

## 1 Description

The **PSR-FSP** SIL coupling relay can be used for power adaptation and electrical isolation in high and low demand applications up to SIL 2 according to IEC 61508 as well as EN 61511.

The safety relay is equipped with two enabling current paths that drop out without delay corresponding to stop category 0 according to EN 60204-1.

By filtering the control controller test pulses, premature failure of the forcibly guided safety relay is prevented.

### Features

- SIL 2 coupling relay for safety-related switching off
- Can be used in high and low demand applications
- Easy proof test according to IEC 61508 due to forcibly guided signal contact
- Integrated DCS test pulse filter
- Two undelayed enable contacts
- Option of screw or spring-cage terminal blocks for plug-in



#### **WARNING: Risk of electric shock**

Observe the safety instructions in the corresponding section!



Make sure you always use the latest documentation.  
It can be downloaded from the product at [phoenixcontact.net/products](http://phoenixcontact.net/products).



This data sheet is valid for all products listed on the following pages.

---

<b>2</b>	<b>Table of contents</b>	
1	Description .....	1
2	Table of contents .....	2
3	Ordering data .....	3
4	Technical data .....	3
5	Basic circuit diagram .....	6
6	Derating .....	6
7	Load curve .....	6
	7.1 Resistive load .....	6
	7.2 Inductive load .....	6
8	Safety notes .....	7
9	Pin assignment .....	8
10	Proof test .....	8

### 3 Ordering data

Description	Type	Order No.	Pcs./Pkt.
Safe coupling relay for SIL 2 high and low-demand applications, couples digital output signals to the I/O, 2 enabling current paths, 1 alarm contact, module for safe state off applications, integrated test pulse filter, plug-in screw terminal blocks, width: 17.5 mm	PSR-SCP- 24DC/FSP2/2X1/1X2	2986575	1
Safe coupling relay for SIL 2 high and low-demand applications, couples digital output signals to the I/O, 2 enabling current paths, 1 signal contact, module for safe state off applications, integrated test pulse filter, plug-in spring-cage terminal block, width: 17.5 mm	PSR-SPP- 24DC/FSP2/2X1/1X2	2986588	1
Documentation	Type	Order No.	Pcs./Pkt.
User manual, English, for applications for PSR safety relay	UM EN SAFETY RELAY APPLICA-TION	2888712	1

### 4 Technical data

Input data	
Nominal input voltage $U_N$	24 V DC
Input voltage range (factor)	0.85 ... 1.1
Typical input current	55 mA
Typical inrush current	max. 100 mA
Typical response time	50 ms
Typical release time	50 ms
Recovery time	1 s
Operating voltage display	Yellow LED
Output data	
Contact type	2 undelayed enabling current paths 1 undelayed confirmation current path
Contact material	AgCuNi, + 0.2 $\mu$ m Au
Minimum switching voltage	15 V AC/DC
Maximum switching voltage	250 V AC/DC
Limiting continuous current	5 A (N/O contact) 100 mA (N/C contact)
Maximum inrush current	5 A
Inrush current, minimum	5 mA
Sq. Total current	$50 \text{ A}^2 (I_{TH}^2 = I_1^2 + I_2^2 + \dots + I_N^2)$ (see derating curve)
Interrupting rating (ohmic load) max.	120 W (24 V DC, $\tau = 0$ ms, N/C contact: 2.4 W) 192 W (48 V DC, $\tau = 0$ ms, N/C contact: 4.8 W) 162 W (60 V DC, $\tau = 0$ ms, N/C contact: 6 W) 66 W (110 V DC, $\tau = 0$ ms, N/C contact: 11 W) 60 W (220 V DC, $\tau = 0$ ms, N/C contact: 22 W)
Maximum interrupting rating (inductive load)	72 W (24 V DC, $\tau = 40$ ms, N/C contact: 2.4 W) 43 W (48 V DC, $\tau = 40$ ms, N/C contact: 4.8 W) 41 W (60 V DC, $\tau = 40$ ms, N/C contact: 6 W) 35 W (110 V DC, $\tau = 40$ ms, N/C contact: 11 W) 48 W (220 V DC, $\tau = 40$ ms, N/C contact: 22 W)
Switching capacity min.	75 mW
Mechanical service life	Approx. $10^7$ cycles
Switching capacity (3600/h cycles)	5 A (24 V (DC13)) 5 A (230 V (AC15))
Output fuse	10 A gL/gG (N/O contact) 6 A gL/gG (N/C contact)

**General data**

Relay type	Electromechanically forcibly guided, dust-proof relay.
Nominal operating mode	100% operating factor
Degree of protection	IP20
Min. degree of protection of inst. location	IP54
Mounting position	any
Mounting type	DIN rail mounting
Air clearances and creepage distances between the power circuits	DIN EN 50178/VDE 0160
Rated insulation voltage	250 V
Rated surge voltage/insulation	6 kV / Safe isolation, increased insulation
Pollution degree	2
Surge voltage category	III

**Dimensions**

	<b>Screw connection</b>	<b>Spring-cage connection</b>
W x H x D	17.5 x 99 x 114.5 mm	17.5 x 112 x 114.5 mm

**Connection data**

	<b>Screw connection</b>	<b>Spring-cage connection</b>
Conductor cross section, solid	0.2 mm <sup>2</sup> ... 2.5 mm <sup>2</sup>	0.2 mm <sup>2</sup> ... 1.5 mm <sup>2</sup>
Conductor cross section, stranded	0.2 mm <sup>2</sup> ... 2.5 mm <sup>2</sup>	0.2 mm <sup>2</sup> ... 1.5 mm <sup>2</sup>
Conductor cross section AWG/kcmil	24 ... 12	24 ... 16
Stripping length	7 mm	8 mm

**Ambient conditions**

Ambient temperature (operation)	-20 °C ... 55 °C
Ambient temperature (storage/transport)	-40 °C ... 70 °C
Max. permissible humidity (storage/transport)	≤ 75 % (Condensation and icing are not permitted based on the average annual temperature)
Maximum altitude	≤ 2000 m (Above sea level)

**Conformance / approvals**

Approvals	
-----------	---

**Safety data**

Stop category according to IEC 60204	0
--------------------------------------	---

**Safety parameters for IEC 61508 - High demand**

SIL	2
PFH <sub>d</sub>	1.00 x 10 <sup>-9</sup>
Diagnostic coverage (DC)	99 %
MTTF <sub>d</sub>	114155.3 Years
Demand rate	< 12 Months
Proof test interval	240 Months
Duration of use	240 Months
The specifications apply assuming the following calculation basis	
d <sub>op</sub>	365 Days
h <sub>op</sub>	24 h
t <sub>Cycle</sub>	3600 s

**Alternative illustration of the device as 1001 structure for process customers**

Equipment type	Type A
HFT	0
SIL	2
Safe Failure Fraction (SFF)	99.61 %
$\lambda_{SD}$	99 FIT
$\lambda_{SU}$	55.7 FIT
$\lambda_{DD}$	99 FIT
$\lambda_{DU}$	1 FIT
$\lambda_{Total}$	254.7 FIT
MTBF	361 Years
PFH	$1.00 \times 10^{-9}$

**Safety parameters for IEC 61508 - Low demand**

SIL	2
Diagnostic coverage (DC)	0 %
$MTTF_d$	1141.55 Years
$PFD_{avg}$	$9.86 \times 10^{-4}$
Proof test interval	15 Months
Duration of use	240 Months

**Alternative illustration of the device as 1001 structure for process customers**

Equipment type	Type A
HFT	0
SIL	2
Safe Failure Fraction (SFF)	81.97 %
$\lambda_{SD}$	0 FIT
$\lambda_{SU}$	455 FIT
$\lambda_{DD}$	0 FIT
$\lambda_{DU}$	100 FIT
$\lambda_{Total}$	555 FIT
MTBF	185 Years
$PFD_{avg}$	$4.38 \times 10^{-4}$ (For T1 = 1 year)

**Safety characteristic data according to EN ISO 13849**

Category	1
Performance level	c
$MTTF_d$	1141.55 Years
CCF	Passed
Duration of use	240 Months
The specifications apply assuming the following calculation basis	
$d_{op}$	365 Days
$h_{op}$	24 h
$t_{Cycle}$	3600 s

## 5 Basic circuit diagram

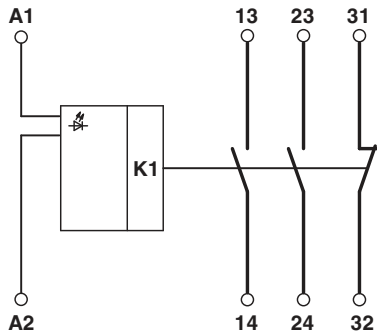

Figure 1 Block diagram

Designation	Explanation
A1/A2	Safety relay input voltage
13/14	Load current path
23/24	Load current path
31/32	Confirmation path

## 6 Derating

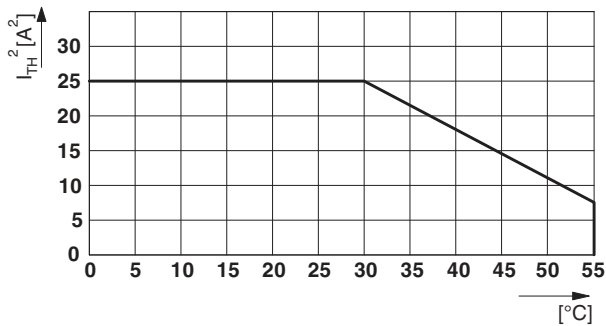

Figure 2 Derating curve

## 7 Load curve

### 7.1 Resistive load

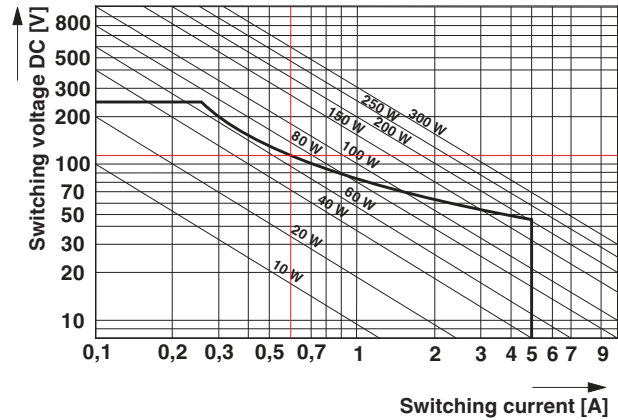

Figure 3 Resistive load

### 7.2 Inductive load

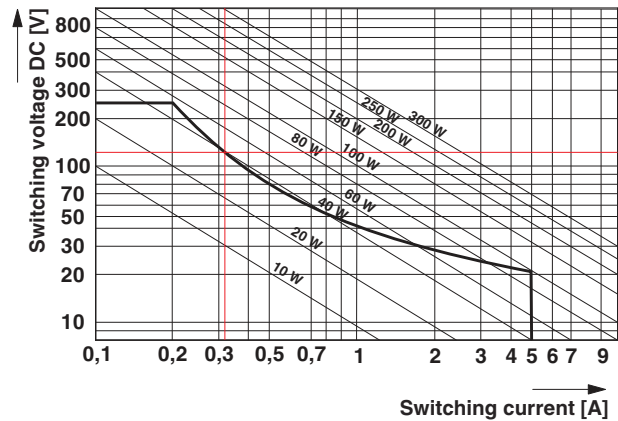

Figure 4 Inductive load

## 8 Safety notes



### **WARNING: Risk of electric shock**

During operation, parts of electrical switching devices carry hazardous voltages.

Before working on the switching device, disconnect the power.

Please observe the safety regulations of electrical engineering and industrial safety and liability associations!

Disregarding these safety regulations may result in death, serious personal injury or damage to equipment.

Startup, mounting, modifications, and upgrades should only be carried out by a skilled electrical engineer!



### **WARNING: Risk of automatic machine restart!**

For emergency stop applications, the machine must be prevented from restarting automatically by a higher-level control system.

Protective covers must not be removed when operating electrical switching devices.



### **WARNING: Danger due to faulty devices!**

The devices may be damaged following an error and correct operation can no longer be ensured.

In the event of an error, replace the device immediately.

Repairs to the device, especially if the housing must be opened, may only be carried out by the manufacturer or authorized persons. Otherwise the warranty is invalidated.



### **NOTE: Risk of damage to equipment due to incorrect installation**

For reliable operation, the safety relay must be installed in housing protected from dust and humidity (IP54).

Carry out wiring according to the application. Refer to the "Application examples" section for this.



### **NOTE: Risk of damage to equipment due to noise emissions**

When operating relay modules the operator must meet the requirements for noise emission for electrical and electronic equipment (EN 61000-6-4) on the contact side and, if required, take appropriate measures.



### **NOTE: Module damage due to polarity reversal**

Polarity reversal places a burden on the electronics and can damage the module.

With resistance monitoring, an error is indicated to the higher-level controller.

Always connect the supply voltage as follows:

A1 to + 24 V

A2 to GND

## 9 Pin assignment

### Operating and indication element

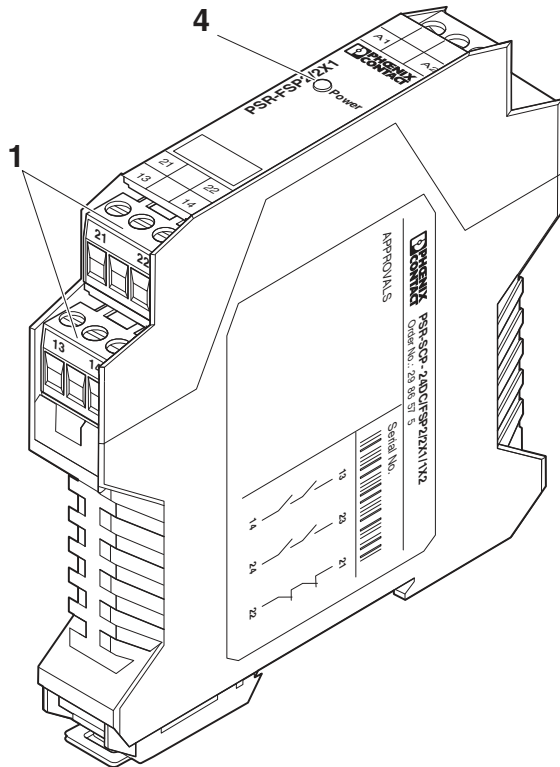

Figure 5 PSR-SCP- 24DC/FSP2/2X1/1X2

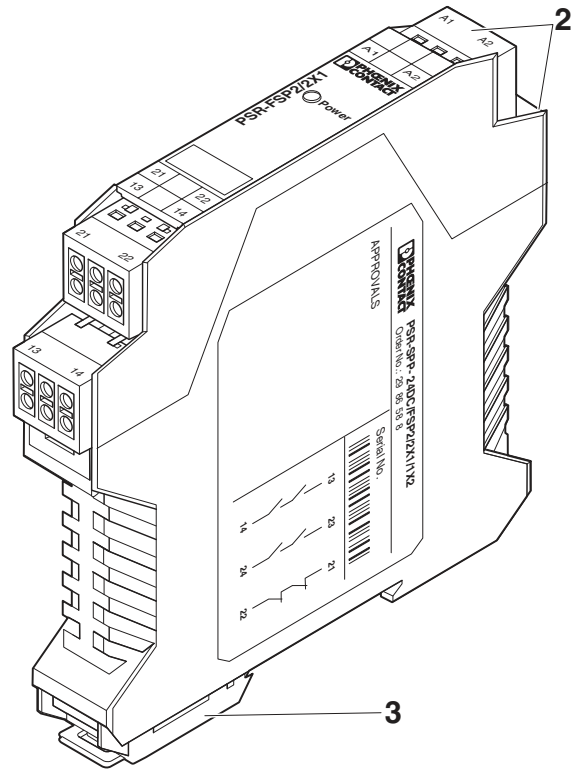

Figure 6 PSR-SPP- 24DC/FSP2/2X1/1X2

Designation	Explanation
1	COMBICON plug-in screw terminal blocks
2	COMBICON plug-in spring-cage terminal blocks
3	Metal lock for mounting on the DIN rail
4	LED status indicator, green - Power

## 10 Proof test

To verify that the emergency stop coupling relay function is operating correctly, reset it and perform a continuity test for confirmation current path (connection terminal blocks 31/32).



**NOTE: Malfunction**

In the event of a faulty continuity test, correct function of the emergency stop coupling relay is no longer possible.

The emergency stop coupling relay must be replaced immediately.