

REVISIONS			
REV.	DESCRIPTION	DATE	APPROVED
A	INITIAL RELEASE	05/05/06	D.N.
B	ECN #7967	07/22/10	D.N.

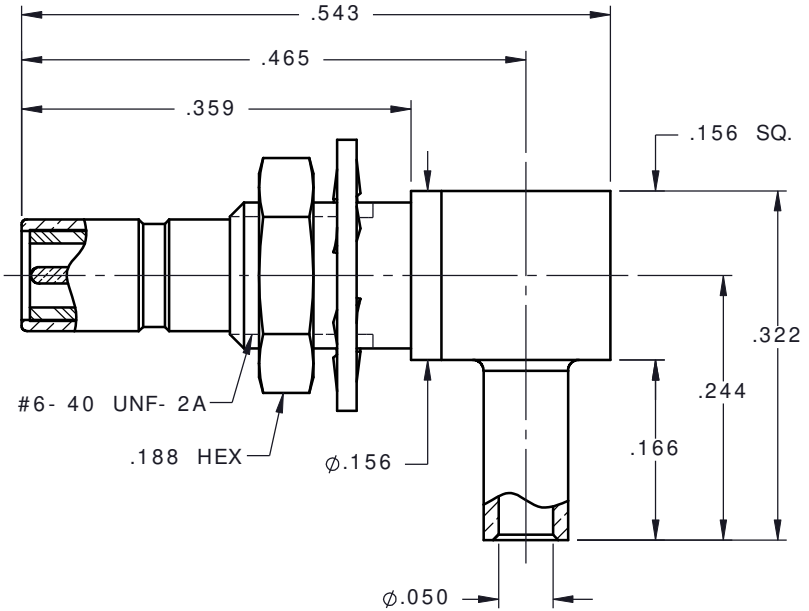
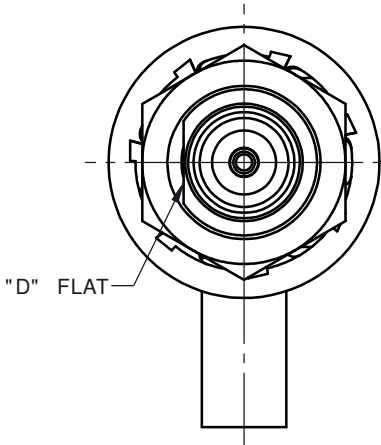

NOTES:

MATERIALS:

1. INTERFACE BODY & CONTACT = BERYLLIUM COPPER PER ASTM B196, ALLOY C17300, TEMPER TD04.
2. INSULATORS = VIRGIN WHITE TEFLON PER ASTM D1710, GRADE 1, TYPE I, CLASS "B".
3. LOCKWASHER = PHOSPHOR BRONZE PER ASTM B139, COPPER ALLOY C53400, TEMPER H04.
4. ALL OTHER METAL PARTS = BRASS PER ASTM B16, ALLOY C36000, TEMPER H02.

FINISHES:

1. CONTACT = GOLD PLATE PER MIL- G- 45204, TYPE II, CLASS 1, GRADE C, OVER .00010 TO .00020 STRESS FREE SULFAMATE NICKEL PER QQ- N- 290.
2. ALL OTHER METAL PARTS = GOLD PLATE PER MIL- G- 45204, TYPE II, CLASS 0, GRADE C, OVER .00010 TO .00020 COPPER STRIKE PER MIL- C- 14550.

UNLESS OTHERWISE SPECIFIED DIMENSIONS ARE IN INCHES TOLERANCES ON		DWN: DATE D.N. 05/05/06	 Property of Radiall This document cannot be reproduced or communicated to a third party without prior written permission of RADIALL.	
DECIMAL	ANGLE	CHKD: DATE M.J. 05/05/06		
		APVD: DATE J.M. 05/05/06	<b>SSMB RIGHT ANGLE JACK BULKHEAD MOUNT DIRECT SOLDER TYPE FOR .045 SEMI- RIGID &amp; SIMILAR CABLES</b>	
REFERENCE:		MATERIALS & FINISHES: SEE NOTES		
ORIGINATED: D.N. DATE: 05/05/06		SHEET 1 OF 1		

7406-1561-011