



30ACBEW_4 series

30W - Single Output AC-DC Converter - Universal Input - Isolated & Regulated

AC-DC Converter

30 Watt

- ⊕ Input voltage range: 85-305VAC and 100-430VDC
- ⊕ Operating ambient temp. range: -40°C to +85°C
- ⊕ Up to 90% efficiency
- ⊕ No-load power consumption <0.1W
- ⊕ 5000m altitude application
- ⊕ EMI performance meets CISPR32/EN55032 CLASS B, EN55014
- ⊕ Meets surge $\pm 2\text{kV}$ without additional circuits
- ⊕ Over-voltage class III (designed to meet EN61558)
- ⊕ Reinforced isolation

The 30ACBEW_4 series AC-DC converters is one of new generation compact size power converter. It features wide AC input and at the same time accepts DC input voltage, low power consumption, high efficiency, high reliability, reinforced isolation. It offers good EMC performance compliant to IEC/EN61000-4 and CISPR32/EN55032 and meets IEC/EN/UL62368/EN60335/EN61558 standards. The converters are widely used in industrial, power, home appliances, instrumentation, communication and civil applications. For extremely harsh EMC environment, we recommend using the application circuit show in design reference of this datasheet.



Common specifications			
Short Circuit Protection	Hiccup, continuous, self-recovery		
Operating temperature	-40°C ~ +85°C (with derating)		
Storage temperature	-40°C ~ +85°C		
Humidity (non-condensing)	95%RH MAX		
Sodlring temperature	Wave-soldering: 260 \pm 5°C; time: 5 - 10s Manual-welding: 360 \pm 10°C; time: 3 - 5s		
Power derating	• -40°C to -25°C (<115VAC) - 5V	2.67	%/°C
	• -40°C to -25°C (<115VAC) others	1.33	%/°C
	• +50°C to +70°C	2.5	%/°C
	• +70°C to +85°C	0.67	%/°C
	• 85VAC - 100VAC	1.33	%/VAC
	• 277VAC - 305VAC	0.72	%/VAC
	• 2000m - 5000m	6.7	%/Km
Isolation - Input-output	Electric Strength Test for 1min., leakage current <5mA	4200 (min.)	VAC
Insulation Resistance - Input-output	At 500VDC	100 (min.)	M Ω
Safety standards	leakage current <5mA		
Safety Certification	IEC/EN/UL62368/EN60335/EN61558		
Safety class	CLASS II		
Vibration	10 ~ 500Hz, 5G 10min./1cycle, period for 60min. Each along X, Y, Z axes		
MTBF	>500,000h @25°C		
Case material	Black plastic, flame-retardant and heat-resistant (UL94V-0)/Metal		
Cooling	Free air convection		
Dimension	DIP package	69.50 x 39.00 x 24.00 mm	
	Chassis mounting	96.10 x 54.00 x 32.50 mm	
	Din-Rail mounting	96.10 x 54.00 x 37.10 mm	
Weight	DIP package	100g (Typ.)	
	chassis mounting	147g (Typ.)	
	Din-Rail mounting	190g (Typ.)	

Input specifications					
Item	Test conditions	Min	Typ	Max	Units
Input Voltage Range	• AC input • DC input	85 100		305 430	VAC VDC
Input Frequency	Full load	47		63	Hz
Input Current	• 115VAC • 230VAC			0.75 0.5	A A
Inrush Current	• 115VAC • 230VAC		25 50	0.75 0.5	A A
Leakage Current	277VAC/50Hz	0.1mA RMS Max.			
Built In Fuse	2A/300V, slow-blow				
Hot Plug	Unavailable				

Output specifications					
Item	Test conditions	Min	Typ	Max	Units
Output voltage accuracy	• 3.3V • 5V/9V/12V/15V/24V/48V		± 3 ± 2		% %
Line regulation	Full load		± 0.5		%
Load regulation	0%-100% load • 3.3V • 5V • 9V/12V/15V/24V/48V		± 2 ± 1.5 ± 1		% % %
Ripple & noise	20MHz bandwidth (peak-to-peak value) • 3.3V/5V/9V/12V/15V • 24V/48V			100 150	mV mV
Stand-by power consumption	230VAC			0.1	W
Minimum load		0			%
Hold-up time (full load)	• 230VAC input • 115VAC input			50 10	ms ms

*The "Tip and barrel method" is used for ripple and noise test, output parallel 10uF electrolytic capacitor and 1uF ceramic capacitor, please refer to AC-DC Converter Application Notes for specific information.

Protection specifications		
Over-current protection	$\geq 110\%I_o$, self-recovery	
Over-voltage protection	3.3VDC Output	$\leq 6.3\text{VDC}$ (Output voltage hiccup)
	5VDC Output	$\leq 16\text{VDC}$ (Output voltage hiccup)
	9VDC Output	$\leq 16\text{VDC}$ (Output voltage hiccup)
	12VDC Output	$\leq 16\text{VDC}$ (Output voltage hiccup)
	15VDC Output	$\leq 25\text{VDC}$ (Output voltage hiccup)
	24VDC Output	$\leq 35\text{VDC}$ (Output voltage hiccup)
	48VDC Output	$\leq 60\text{VDC}$ (Output voltage hiccup)

Example:

30ACBEW_05S4

30 = 30Watt; AC = AC-DC; BE = series; W = Wide input range = 85 - 305VAC; 05 = 5Vout; S = Single Output; 4 = 4kVAC isolation

Note:

- If the product is not operated within the required load range, the product performance cannot be guaranteed to comply with all parameters in the datasheet;
- Unless otherwise specified, parameters in this datasheet were measured under the conditions of $T_a = 25^\circ\text{C}$, humidity <75% with nominal input voltage and rated output load;
- All index testing methods in this datasheet are based on our company corporate standards;
- We can provide product customization service, please contact our technicians directly for specific information;
- Products are related to laws and regulations: see „Features“ and „EMC“;
- Our products shall be classified according to ISO14001 and related environmental laws and regulations, and shall be handled by qualified units.

30ACBEW_4 series

30W - Single Output AC-DC Converter - Universal Input - Isolated & Regulated

Common specifications						
Emissions	CE		CISPR32/EN55032 EN55014-1	CLASS B		
Emissions	RE		CISPR32/EN55032 EN55014-1	CLASS B		
Immunity	ESD		IEC/EN 61000-4-2 IEC/EN55014-2	Contact ±8KV / Air ±15KV		Perf. Criteria A Perf. Criteria A
Immunity	RS		IEC/EN61000-4-3 IEC/EN55014-2	10V/m		perf. Criteria A Perf. Criteria A
Immunity	EFT		IEC/EN61000-4-4 IEC/EN61000-4-4 IEC/EN55014-2	±2KV ±4KV (See Fig.2 for recommended circuit)		perf. Criteria A perf. Criteria A perf. Criteria A
Immunity	Surge		IEC/EN61000-4-5 IEC/EN61000-4-5	line to line ±2KV line to line ±2KV/line to ground ±4KV (See Fig.2 for recommended circuit)		perf. Criteria A perf. Criteria A
Immunity	CS		IEC/EN61000-4-6 IEC/EN55014-2	10Vr.m.s		perf. Criteria A Perf. Criteria A
Immunity	Voltage dip, short interruption and voltage variation		IEC/EN61000-4-11 IEC/EN55014-2	0%, 70%		perf. Criteria B perf. Criteria B

Product Selection Guide

Approval	Model	Power [W]	Output voltage [V, Nominal]	Output current [mA, Nominal]	Capacitive Load [μF, max]	Efficiency [@230VAC, %, typ]
UL	30ACBEW_03S4	19.8	3.3V	6000mA	6600	85
UL	30ACBEW_05S4	30	5V	6000mA	6600	86
UL	30ACBEW_09S4	30.6	9V	3400mA	4400	88
UL	30ACBEW_12S4	30	12V	2500mA	4400	90
UL	30ACBEW_15S4	30	15V	2000mA	3300	90
UL	30ACBEW_24S4	31.2	24V	1300mA	1000	88
UL	30ACBEW_48S4	30.2	48V	630mA	470	90

Product Characteristic Curve

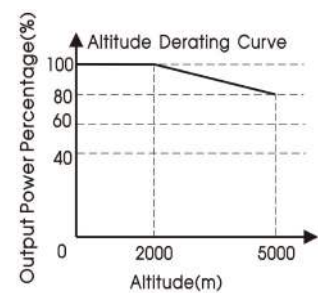
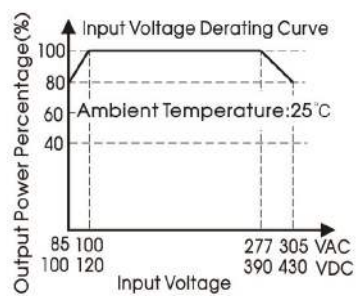
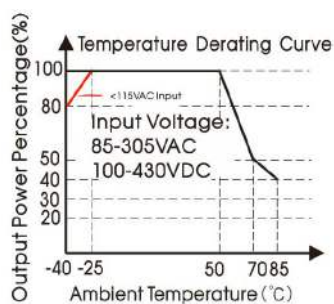

Note:

① With an AC input between 85-100V/277-305VAC and a DC input between 100-120V/390-430VDC, the output power must be derated as per temperature derating curves;

② This product is suitable for applications using natural air cooling; for applications in closed environment please consult factory or one of our FAE.

Efficiency

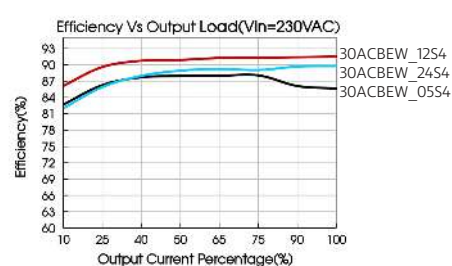
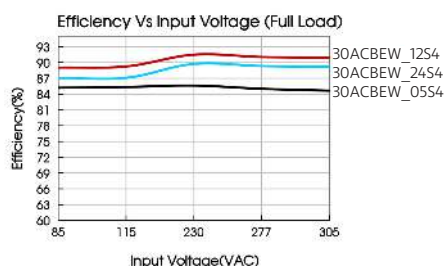

30ACBEW_4 series

30W - Single Output AC-DC Converter - Universal Input - Isolated & Regulated

Typical application

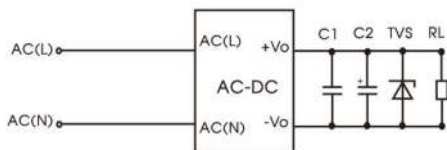

Fig. 1: Typical circuit diagram

Part No.	C1	C2	TVS
30ACBEW_03S4	1uF/100V	10uF/50V	SMBJ7.0A
30ACBEW_05S4	1uF/100V	10uF/50V	SMBJ7.0A
30ACBEW_09S4	1uF/100V	10uF/50V	SMBJ12A
30ACBEW_12S4	1uF/100V	10uF/50V	SMBJ20A
30ACBEW_15S4	1uF/100V	10uF/50V	SMBJ20A
30ACBEW_24S4	1uF/100V	10uF/50V	SMBJ30A
30ACBEW_48S4	1uF/100V	10uF/63V	SMBJ64A

Output Filter Components:

- ① C1 is a ceramic capacitor used for filtering high-frequency noise and TVS is a recommended suppressor diode to protect the application in case of a converter failure;
- ② This circuit is recommended for indoor use.

EMC compliance recommended circuit

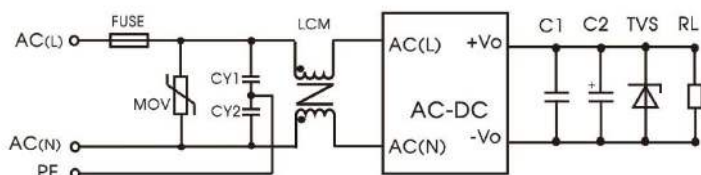

Fig 2: EMC application circuit with higher requirements

Component	Recommended value
FUSE	3.15A/300V, slow-blow, required
MOV	S14K350
CY1/CY2	1nF/400VAC
LCM	10mH

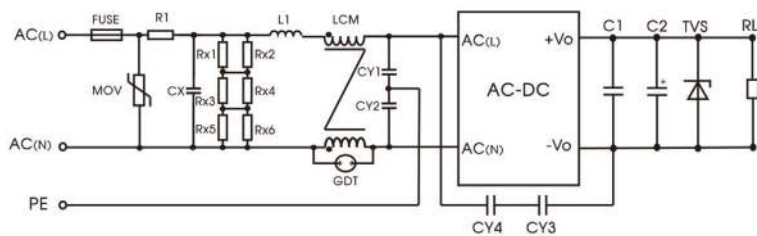
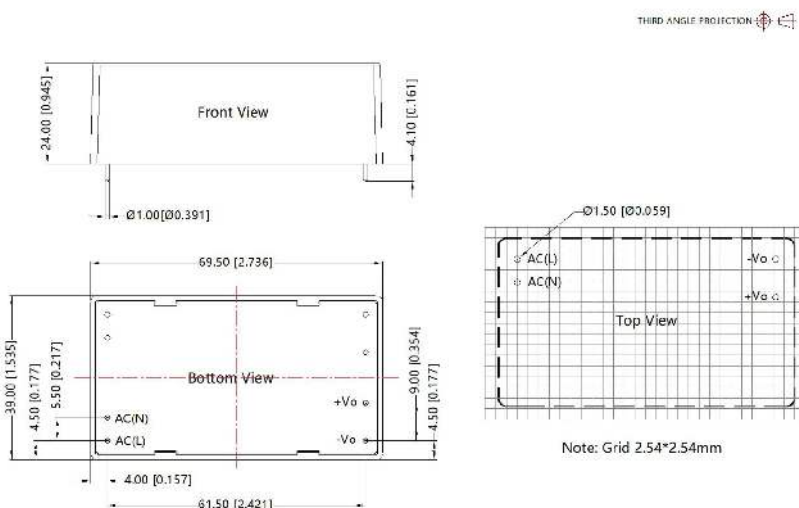

Fig. 3: Recommended circuit for class I equipment

Component	Recommended value
FUSE	3.15A/300V, slow-blow, required
MOV	S14K350
CX	334K/305VAC
R1	6.8Ω/5W (wire-wound resistor)
L1	1.2mH/0.5A
CY1/CY2	2.2nF/400VAC
CY3/CY4	1nF/400VAC
GDT	300V/1KA
LCM	20mH

Dimensions and Recommended Layout



Note:
Unit: mm[inch]
Pin diameter tolerances: ±0.10[±0.004]
General tolerances: ±0.50[±0.020]

30ACBEW_4 series

30W - Single Output AC-DC Converter - Universal Input - Isolated & Regulated

Dimensions and Recommended Layout Chassis mounting

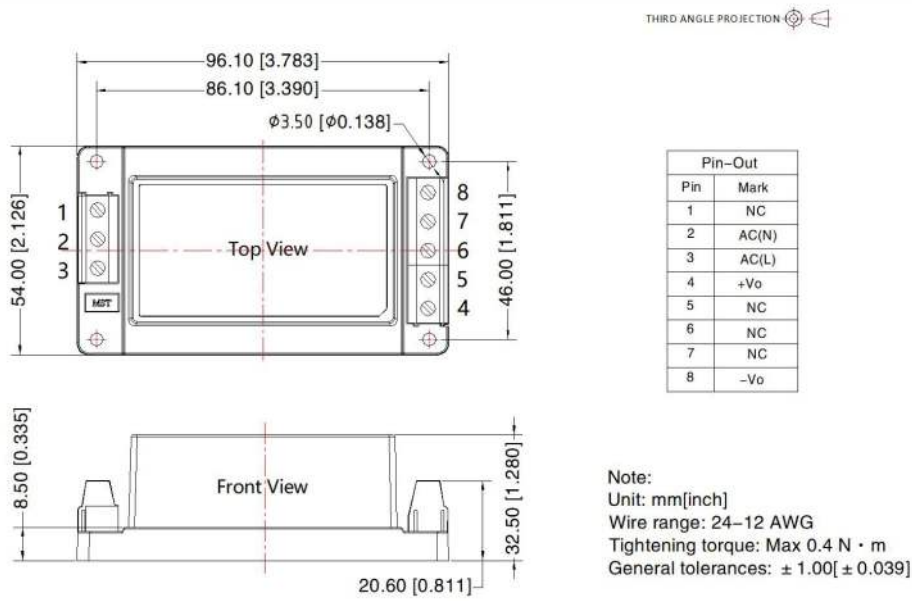

Dimensions and Recommended Layout Din-Rail mounting

