

PART NUMBER	REVISION	DESCRIPTION	FEED TYPE
2266505-1	B	FINE CRIMP HEIGHT ADJUST	MECHANICAL
2266505-2	B	FINE CRIMP HEIGHT ADJUST	PNEUMATIC
7-2266505-1	B	MECHANICAL AND CRIMP TOOLING KIT	MECHANICAL
7-2266505-2	B	PNEUMATIC AND CRIMP TOOLING KIT	PNEUMATIC
7-2266505-7	A	CRIMP TOOLING KIT	-

ATLANTIC VERSION TERMINATOR INTERFACE ADAPTER

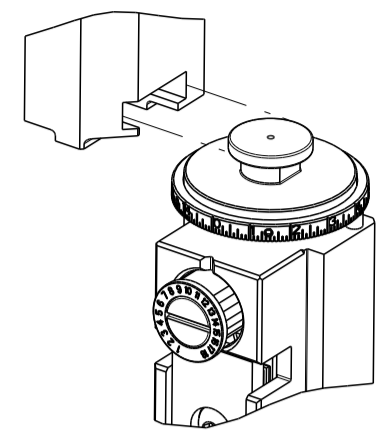

APPLICATOR DATA		
CRIMP	SIZE	TYPE
WIRE	1.27 mm [.050]	F
INSUL	1.60 mm [.063]	F

APPLICATOR INSTRUCTIONS 408-35042

TERMINAL DATA: ITT CANNON TERMINAL TE CRIMP SPECIFICATION			
TERMINAL NAME: TERMINAL			
WIRE STRIP LENGTH	INSULATION DIAMETER RANGE		
2.10-2.86 mm [.083-.113 IN]	Ø0.95-1.27 mm [.038-.050 IN]		
TERMINAL APPLICATION SPECIFICATION	NONE		
TERMINALS APPLIED			
TE TERMINAL	ITT CANNON TERMINAL	TE TERMINAL	ITT CANNON TERMINAL
2113587-1	980-2000-924	2113587-2	980-2000-945

WIRE SIZE	CRIMP HEIGHT mm [INCH]	CRIMP HEIGHT REFERENCE SETTING
20 AWG OR 0.50mm ²	0.90 +/- 0.05 [.035 +/- .002]	5.1
22 AWG OR 0.35mm ²	0.80 +/- 0.05 [.031 +/- .002]	6.1
24 AWG OR 0.20mm ²	0.71 +/- 0.05 [.028 +/- .002]	7.2

- 1. RECOMMENDED SPARE PARTS
- 2. REFER TO SUPPLIED INSTRUCTION SHEET FOR CLEANING, LUBRICATION AND STORAGE OF APPLICATOR.
- 3. APPLY PART NUMBER 2-23419-6 LOCTITE TO THREADS OF ITEM 242.
- 4. CRIMP HEIGHT REFERENCE SETTING WAS THE SETTING USED WHEN THE APPLICATOR WAS QUALIFIED AT THE FACTORY. ADJUSTMENT MAY BE NECESSARY WHEN RUNNING APPLICATOR IN THE FIELD.
- 5. TERMINAL LUBRICANT IS RECOMMENDED.
- 6. UNLESS SPECIFIED OTHERWISE TORQUE VALUES SHALL BE USED PER DOCUMENT, 101-35000.

***WARNING**
ON INSTALLATION, SET WIRE DISC TO CRIMP HEIGHT REFERENCE SETTING FOR LARGEST WIRE SIZE. CRIMP HEIGHT REFERENCE SETTINGS GREATER THAN THE VALUE SHOWN MAY CAUSE DAMAGE TO THE CRIMP TOOLING. REFER TO THE INSTRUCTION SHEET FOR PROPER SETUP AND ADJUSTMENTS.

ATLANTIC VERSION
Shown on sheets 1 of 4 & 2 of 4
(Pacific version shown on sheets 3 of 4 & 4 of 4)

LOC	DIST	REVISIONS					
		P	LTN	DESCRIPTION	DATE	OWN	APVD
A	66	1		DEVELOPMENT	12SEP2014	XZ	UG
		A		RELEASED	27OCT2014	BH	GB
		B		ECR-19-002533	17FEB2019	TB	CT

-	1	-	1	-	2119640-1	PUSH ROD, AIR FEED	250	
-	1	-	1	-	1803259-1	BUSHING, FLANGED	249	
-	1	-	1	-	2119641-1	FEED CAM, AIR FEED	248	
-	1	1	1	1	2119082-5	CAM, SNAIL, INSULATION ADJUSTMENT	244	
-	1	1	1	1	2079764-1	WASHER, WAVE SPRING, CREST-TO-CREST	243	
3	-	1	1	1	2119083-1	RETAINER, INSULATION DIAL	242	
-	1	1	1	1	7-18023-7	SCR, SKT HD CAP M3 X 4.0	241	
-	-	1	-	1	2119580-1	MECHANICAL FEED ASSEMBLY	239	
-	1	-	1	-	2063440-1	AIR FEED MODULE	238	
-	2	-	2	-	21045-3	RING, RETAIN, EXTERN, 3/16 CRESCENT	172	
-	REF	REF	REF	REF	994970-2	COUNTER, MAGNETIC	164	
-	1	-	1	-	240638-1	SPRING, FEED FINGER	163	
-	1	-	1	-	3-23627-7	PIN, RETAIN, GRVD, 3/16 X .854	137	
-	1	-	1	-	2119799-1	HOLDER, FEED FINGER, AF	136	
5	-	1	1	1	2119955-1	ASSY, LUBRICATOR, SIDE FEED	113	
-	1	1	1	1	2844908-1	SCREW, LOCKING	99	
-	1	1	1	1	2844907-1	POST, LOCKING	98	
-	1	1	1	1	455888-5	SPACER, CRIMPER	82	
-	1	1	1	1	1803607-1	DOCUMENTATION PACKAGE	71	
-	1	1	1	1	2119740-1	TAG, IDENTIFICATION	67	
-	2	2	2	2	2168078-1	SCREW, DRIVE, RH, RoHS, 2 x .188	66	
-	1	1	1	1	2168083-2	SCR, SKT HD CAP, RoHS, M4 X 8.0	60	
-	1	1	1	1	5-18022-5	SCR, HEX HD CAP, M4 X 6.0	59	
-	1	1	1	1	1338685-1	PAWL, FEED	56	
-	4	4	4	4	2168083-3	SCR, SKT HD CAP, RoHS, M4 X 12.0	54	
-	2	2	2	2	2168083-3	SCR, SKT HD CAP, RoHS, M4 X 12.0	53	
-	1	1	1	1	5018030-1	NUT, HEX, REG, RoHS, M3	52	
-	1	1	1	1	811242-5	BUMPER, HOLD DOWN	51	
-	1	1	1	1	690753-2	SPACER, TONKER	50	
-	1	2	1	2	18023-9	SCR, SKT HD CAP M4 X 6.0	49	
-	-	1	-	1	2119652-1	FEED CAM, PRE FEED	48	
-	-	1	-	1	2119653-1	FEED CAM, POST FEED	47	
-	1	1	1	1	1803583-9	APPLICATOR BASIC ASSEMBLY, SF	46	
-	1	1	1	1	1803515-1	RAM ASSEMBLY, SF ATLANTIC	44	
-	1	1	1	1	1803602-1	SCR, BHSC, RoHS (M8 X 25)	41	
-	1	1	1	1	1752356-1	SUPPORT, TERMINAL	34	
-	2	2	2	2	2079383-5	SCR, BHSC, RoHS (M4 X 20)	33	
-	2	2	2	2	2-2844962-6	SPACER, CYLINDRICAL, STRIP GUIDE	30	
-	1	1	1	1	2844992-1	ASSEMBLY, STRIP GUIDE	29	
-	1	1	1	1	455888-3	SPACER, CRIMPER	28	
-	1	1	1	1	1320928-2	STRIP GUIDE	24	
-	1	1	1	1	2168083-2	SCR, SKT HD CAP, RoHS, M4 X 8.0	21	
-	2	2	2	2	1-18028-2	WASHER, FLAT, REG M4	20	
-	1	1	1	1	2119533-4	STRIPPER, SIDE FEED	19	
1	-	1	1	1	2119806-1	INSERT, SHEAR	13	
-	1	1	1	1	3-22280-3	SPRING, COMPRESSION	12	
-	1	1	1	1	1-356885-4	STOP, SHEAR	11	
-	1	1	1	1	2119805-1	SHEAR HOLDER, FRONT	10	
1	-	1	1	1	1803095-1	FLOATING SHEAR, FRONT	9	
1	1	2	2	1	1-1803171-1	ANVIL, COMBINATION	8	
-	1	1	1	1	1-240641-3	SPACER	7	
-	-	-	-	-	-	-	6	
-	1	1	1	1	2119757-4	DEPRESSOR, SHEAR	5	
-	1	1	1	1	2-238011-5	BLOCK, CRIMPER SPACER	4	
1	1	2	2	1	1803016-6	CRIMPER, INSULATION F	3	
-	-	-	-	-	-	-	2	
1	1	2	2	1	2-568176-5	CRIMPER, WIRE	1	
-	77	-72	-71	-2	-1	PART NO	DESCRIPTION	ITEM NO

DIMENSIONS:		TOLERANCES UNLESS OTHERWISE SPECIFIED:		MATERIAL:		FINISH:		WEIGHT:		SCALE:		SHEET:		REV:	
mm	0 PLC ±	1 PLC ±	2 PLC ±	3 PLC ±	4 PLC ±	ANGLES	FINISH			A1	00779	1	of	4	B

LOC	DIST	REVISIONS					
A	66	P	LTN	DESCRIPTION	DATE	DWN	APVD
		-		SEE SHEET 1			

FEED TYPE MECHANICAL

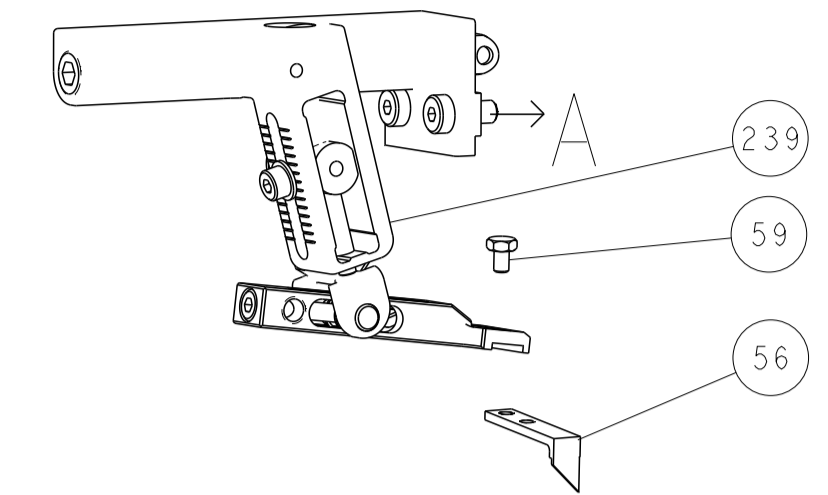

PNEUMATIC

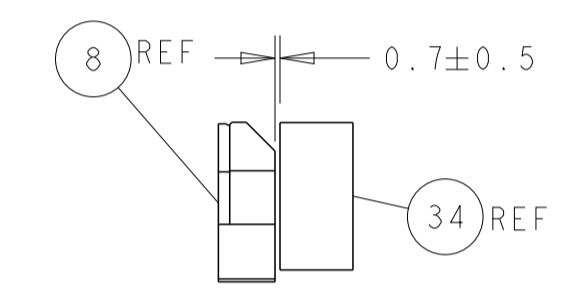
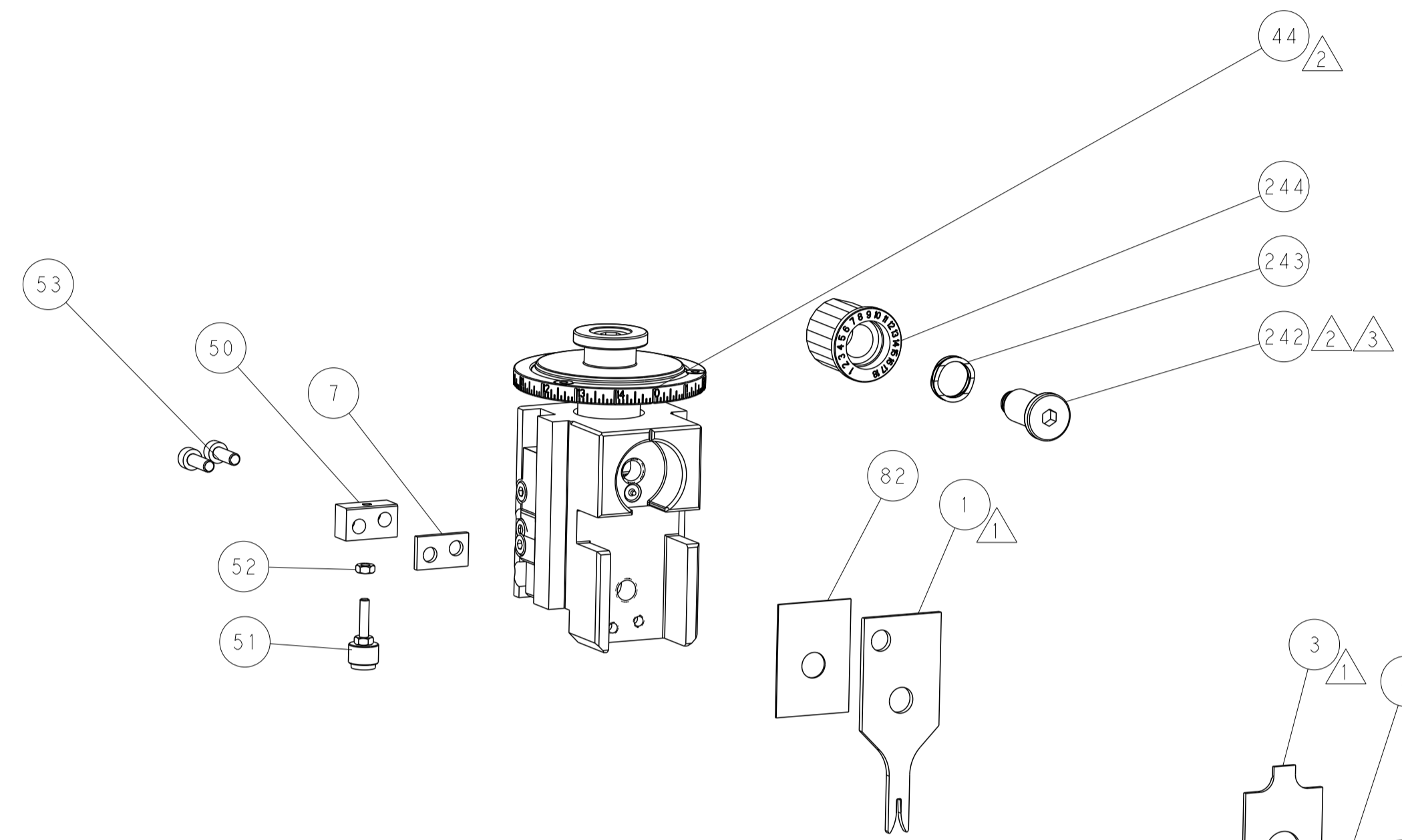
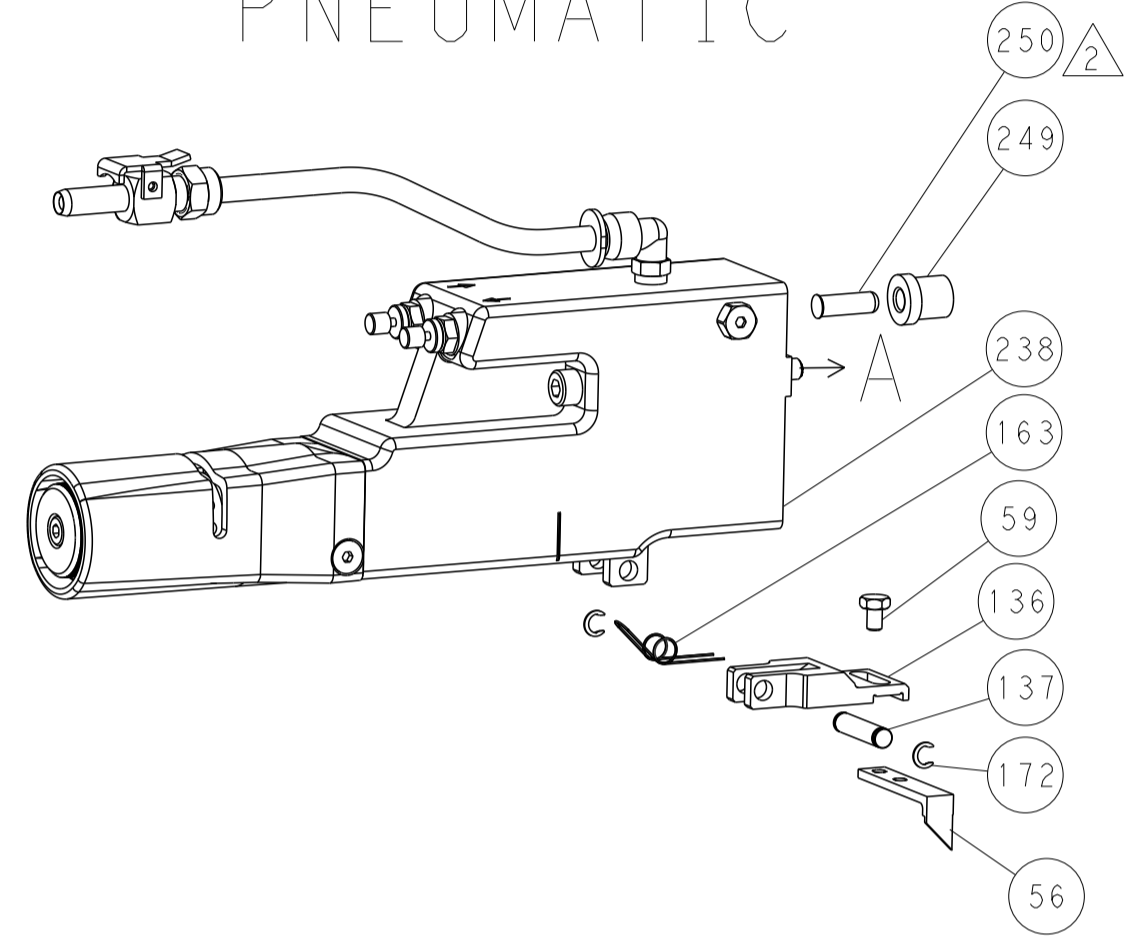

TERMINAL SUPPORT LOCATION

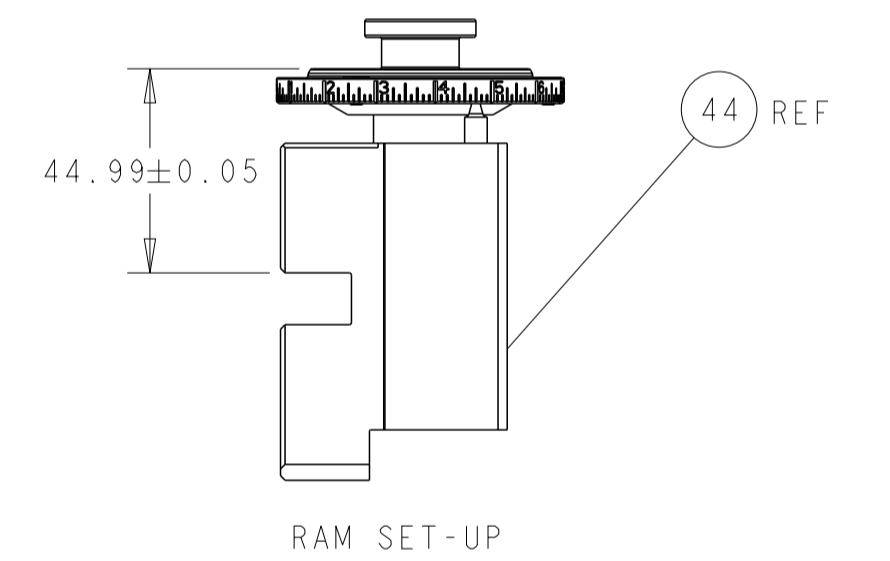

RAM SET-UP

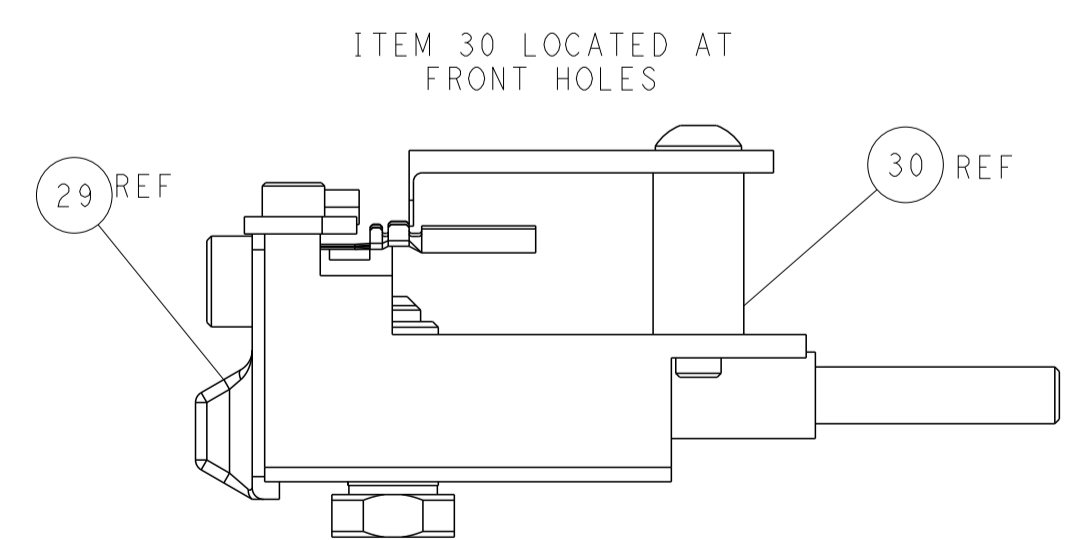
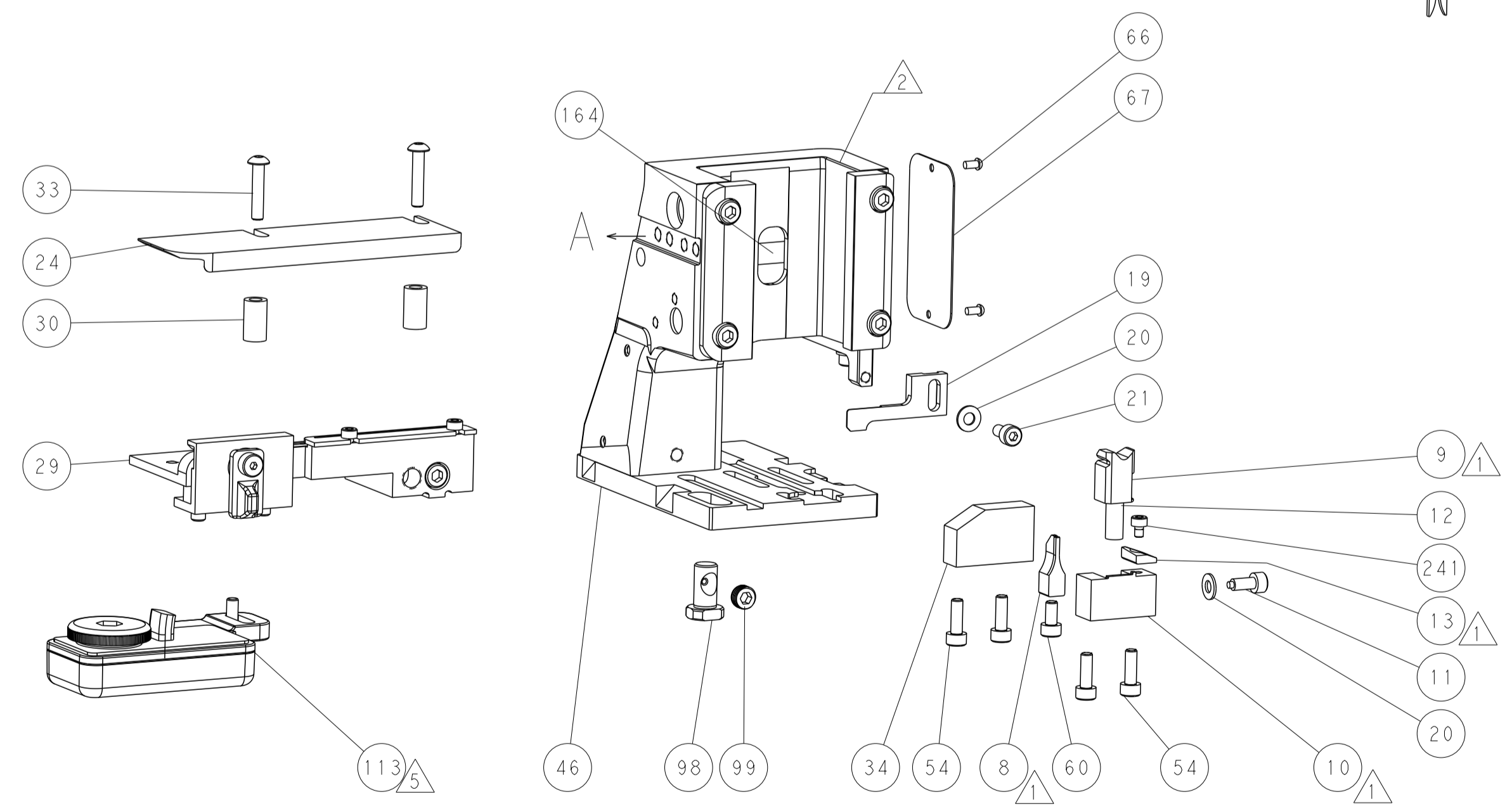

FEED TRACK POSITION GUIDE BY WIRE BARREL

CAM POSITIONS

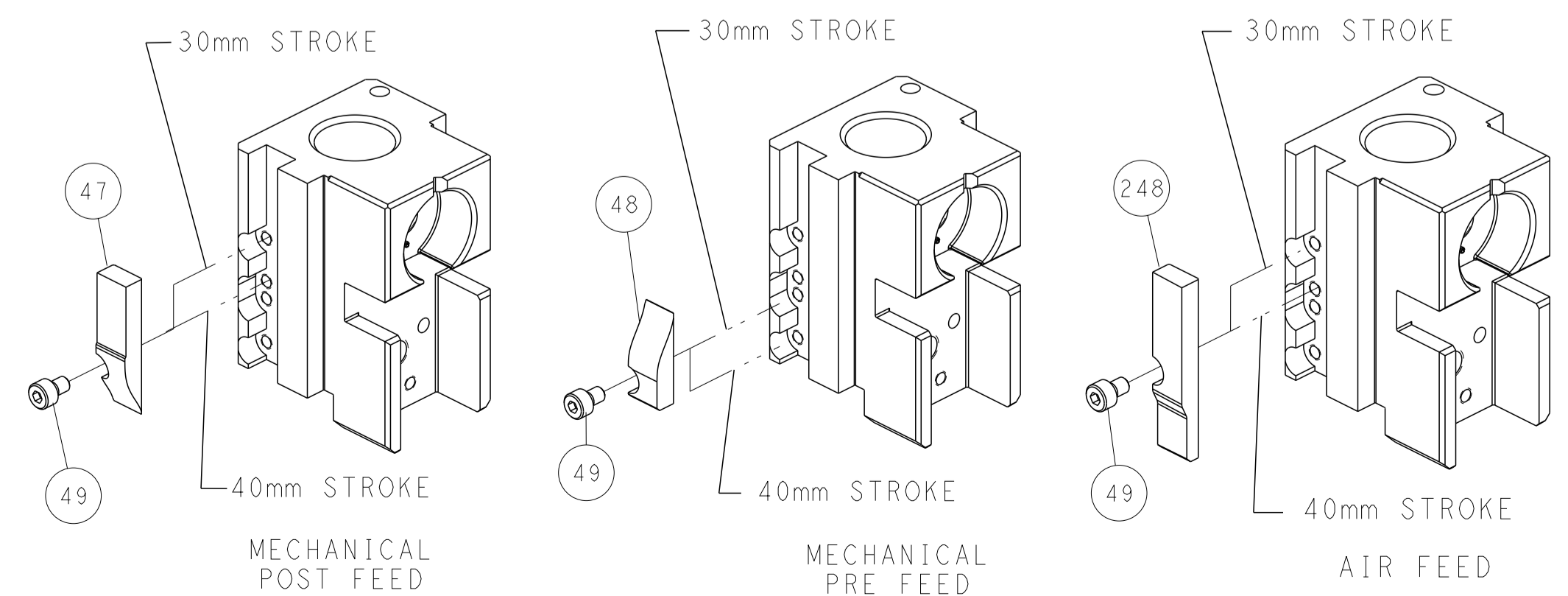

ATLANTIC VERSION
 Shown on sheets 1 of 4 & 2 of 4
 (Pacific version shown on sheets 3 of 4 & 4 of 4)

DIMENSIONS: mm 		TOLERANCES UNLESS OTHERWISE SPECIFIED: 0 PLC ± 1 PLC ± 2 PLC ± 3 PLC ± 4 PLC ± ANGLES ± FINISH		DWN X.ZHAO 12SEP2014 CHK T.ELBIN 12SEP2014 APVD H.GUO 12SEP2014 PRODUCT SPEC APPLICATION SPEC WEIGHT Customer Accessible Production Drawing		NAME Ocean Side Feed Applicator SIZE CAGE CODE DRAWING NO A1 00779 C=2266505 SCALE 1:2 SHEET 2 OF 4 REV B		RESTRICTED TO TE Connectivity Harrisburg, PA 17105-3608	
--------------------	--	---	--	---	--	--	--	---	--

PART NUMBER	REVISION	DESCRIPTION	FEED TYPE
2-2266505-1	B	FINE CRIMP HEIGHT ADJUST	MECHANICAL
2-2266505-2	B	FINE CRIMP HEIGHT ADJUST	PNEUMATIC
7-2266505-7	A	CRIMP TOOLING KIT	-

PACIFIC VERSION TERMINATOR
INTERFACE ADAPTER



APPLICATOR DATA		
CRIMP	SIZE	TYPE
WIRE	1.27 mm [.050]	F
INSUL	1.60 mm [.063]	F
APPLICATOR INSTRUCTIONS 408-35042		

TERMINAL DATA: ITT CANNON TERMINAL TE CRIMP SPECIFICATION			
TERMINAL NAME: TERMINAL			
WIRE STRIP LENGTH	INSULATION DIAMETER RANGE	TERMINAL APPLICATION SPECIFICATION	TERMINAL LUBRICANT
2.10-2.86 mm [.083-.113 IN]	Ø0.95-1.27 mm [.038-.050 IN]	NONE	-
TERMINALS APPLIED			
TE TERMINAL	ITT CANNON TERMINAL	TE TERMINAL	ITT CANNON TERMINAL
2113587-1	980-2000-924	2113587-2	980-2000-945

WIRE SIZE	CRIMP HEIGHT mm [INCH]	CRIMP HEIGHT REFERENCE SETTING
20 AWG OR 0.50mm ²	0.90+/-0.05 [.035+/-0.002]	5.1
22 AWG OR 0.35mm ²	0.80+/-0.05 [.031+/-0.002]	6.1
24 AWG OR 0.20mm ²	0.71+/-0.05 [.028+/-0.002]	7.2

- 1 RECOMMENDED SPARE PARTS
- 2 REFER TO SUPPLIED INSTRUCTION SHEET FOR CLEANING, LUBRICATION AND STORAGE OF APPLICATOR.
- 3 APPLY PART NUMBER 2-23419-6 LOCTITE TO THREADS OF ITEM 242.
- 4 CRIMP HEIGHT REFERENCE SETTING WAS THE SETTING USED WHEN THE APPLICATOR WAS QUALIFIED AT THE FACTORY. ADJUSTMENT MAY BE NECESSARY WHEN RUNNING APPLICATOR IN THE FIELD.
- 5 TERMINAL LUBRICANT IS RECOMMENDED.
- 6. UNLESS SPECIFIED OTHERWISE TORQUE VALUES SHALL BE USED PER DOCUMENT, 101-35000.

***WARNING**
ON INSTALLATION, SET WIRE DISC TO CRIMP HEIGHT REFERENCE SETTING FOR LARGEST WIRE SIZE. CRIMP HEIGHT REFERENCE SETTINGS GREATER THAN THE VALUE SHOWN MAY CAUSE DAMAGE TO THE CRIMP TOOLING. REFER TO THE INSTRUCTION SHEET FOR PROPER SETUP AND ADJUSTMENTS.

LOC	DIST	REVISIONS					
A	66	P	LTN	DESCRIPTION	DATE	OWN	APVD
-	-	-	-	SEE SHEET 1	-	-	-

-	1	-	2119640-1	PUSH ROD, AIR FEED	250
-	1	-	1803259-1	BUSHING, FLANGED	249
-	1	1	2119082-5	CAM, SNAIL, INSULATION ADJUSTMENT	244
-	1	1	2079764-1	WASHER, WAVE SPRING, CREST-TO-CREST	243
3	-	1	2119083-1	RETAINER, INSULATION DIAL	242
-	1	1	7-18023-7	SCR, SKT HD CAP M3 X 4.0	241
-	-	1	2119580-1	MECHANICAL FEED ASSEMBLY	239
-	1	-	2063440-1	AIR FEED MODULE	238
-	2	-	21045-3	RING, RETAIN, EXTERN, 3/16 CRESCENT	172
-	REF	REF	994970-2	COUNTER, MAGNETIC	164
-	1	-	240638-1	SPRING, FEED FINGER	163
-	1	-	2119641-2	FEED CAM, AIR FEED	151
-	1	1	2168083-8	SCR, SKT HD CAP, RoHS, M4 X 16	144
-	4	4	2168083-9	SCR, SKT HD CAP, RoHS, M4 X 20	143
-	-	1	2119653-2	FEED CAM, POST FEED	142
-	1	1	1-1803583-0	APPLICATOR BASIC ASSEMBLY, SF	141
-	1	1	1803516-1	RAM ASSEMBLY, SF PACIFIC	140
-	1	-	3-23627-7	PIN, RETAIN, GRVD, 3/16 X .854	137
-	1	-	2119799-1	HOLDER, FEED FINGER, AF	136
5	-	1	2119955-1	ASSY, LUBRICATOR, SIDE FEED	113
-	1	1	2844908-1	SCREW, LOCKING	99
-	1	1	2844907-1	POST, LOCKING	98
-	1	1	455888-5	SPACER, CRIMPER	82
-	1	1	1803607-1	DOCUMENTATION PACKAGE	71
-	1	1	2119740-1	TAG, IDENTIFICATION	67
-	2	2	2168078-1	SCREW, DRIVE, RH, RoHS, 2 x .188	66
-	1	1	5-18022-5	SCR, HEX HD CAP, M4 X 6.0	59
-	1	1	1338685-1	PAWL, FEED	56
-	2	2	2168083-3	SCR, SKT HD CAP, RoHS, M4 X 12.0	53
-	1	1	5018030-1	NUT, HEX, REG, RoHS, M3	52
-	1	1	811242-5	BUMPER, HOLD DOWN	51
-	1	1	690753-2	SPACER, TONKER	50
-	1	2	18023-9	SCR, SKT HD CAP M4 X 6.0	49
-	-	1	2119652-1	FEED CAM, PRE FEED	48
-	1	1	1803602-1	SCR, BHSC, RoHS (M8 X 25)	41
-	1	1	1752356-1	SUPPORT, TERMINAL	34
-	2	2	2079383-5	SCR, BHSC, RoHS (M4 X 20)	33
-	2	2	2-2844962-6	SPACER, CYLINDRICAL, STRIP GUIDE	30
-	1	1	2844992-1	ASSEMBLY, STRIP GUIDE	29
-	1	1	455888-3	SPACER, CRIMPER	28
-	1	1	1320928-2	STRIP GUIDE	24
-	1	1	2168083-2	SCR, SKT HD CAP, RoHS, M4 X 8.0	21
-	2	2	1-18028-2	WASHER, FLAT, REG M4	20
-	1	1	2119533-4	STRIPPER, SIDE FEED	19
7	-	1	2119806-1	INSERT, SHEAR	13
-	1	1	3-22280-3	SPRING, COMPRESSION	12
-	1	1	1-356885-4	STOP, SHEAR	11
8	-	1	2119805-1	SHEAR HOLDER, FRONT	10
9	-	1	1803095-1	FLOATING SHEAR, FRONT	9
10	1	1	1-1803171-1	ANVIL, COMBINATION	8
-	1	1	1-240641-3	SPACER	7
-	-	-	-	-	6
-	1	1	2119757-4	DEPRESSOR, SHEAR	5
-	1	1	2-238011-5	BLOCK, CRIMPER SPACER	4
11	1	1	1803016-6	CRIMPER, INSULATION F	3
-	-	-	-	-	2
12	1	1	2-568176-5	CRIMPER, WIRE	1
-77	-22	-21	PART NO	DESCRIPTION	ITEM NO

PACIFIC VERSION
Shown on sheets 3 of 4 & 4 of 4
(Atlantic version shown on sheets 1 of 4 & 2 of 4)

<small>THIS DRAWING IS UNPUBLISHED. IT IS THE PROPERTY OF STC CONNECTIVITY CORPORATION. IT IS TO BE USED ONLY FOR THE PROJECT AND FOR THE CUSTOMER'S USE. IT IS TO BE KEPT IN CONFIDENTIALITY AND NOT TO BE REPRODUCED OR TRANSMITTED IN ANY FORM OR BY ANY MEANS, ELECTRONIC OR MECHANICAL, INCLUDING PHOTOCOPYING, RECORDING, OR BY ANY INFORMATION STORAGE AND RETRIEVAL SYSTEM. PERMISSION TO REPRODUCE THIS DRAWING IN ANY FORM OR BY ANY MEANS, ELECTRONIC OR MECHANICAL, INCLUDING PHOTOCOPYING, RECORDING, OR BY ANY INFORMATION STORAGE AND RETRIEVAL SYSTEM, MUST BE OBTAINED FROM STC CONNECTIVITY CORPORATION.</small>		DWN X. ZHAO 12SEP2014 CHK T. ELBIN 12SEP2014 APVD J. GUO 12SEP2014	NAME Ocean Side Feed Applicator
DIMENSIONS: mm 	TOLERANCES UNLESS OTHERWISE SPECIFIED: 0 PLC ± 1 PLC ± 2 PLC ± 3 PLC ± 4 PLC ± ANGLES ± FINISH	SIZE A1 CAGE CODE 00779 DRAWING NO C=2266505	RESTRICTED TO - SCALE 1:2 SHEET 3 OF 4 REV B
MATERIAL -		WEIGHT -	Customer Accessible Production Drawing

LOC	DIST	REVISIONS					
A	66	P	LTN	DESCRIPTION	DATE	DMN	APVD
		-		SEE SHEET 1			

FEED TYPE MECHANICAL

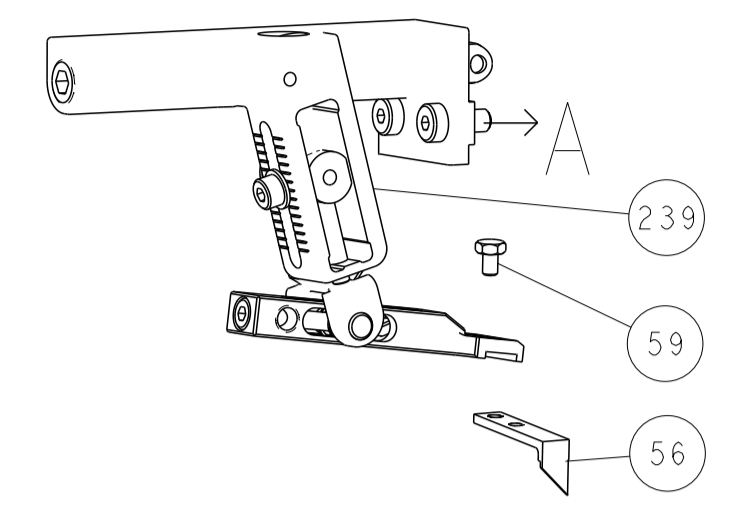

PNEUMATIC

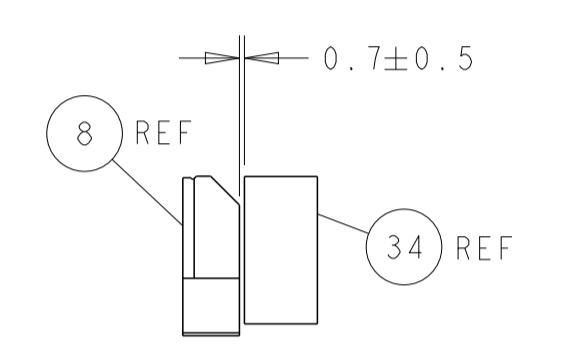
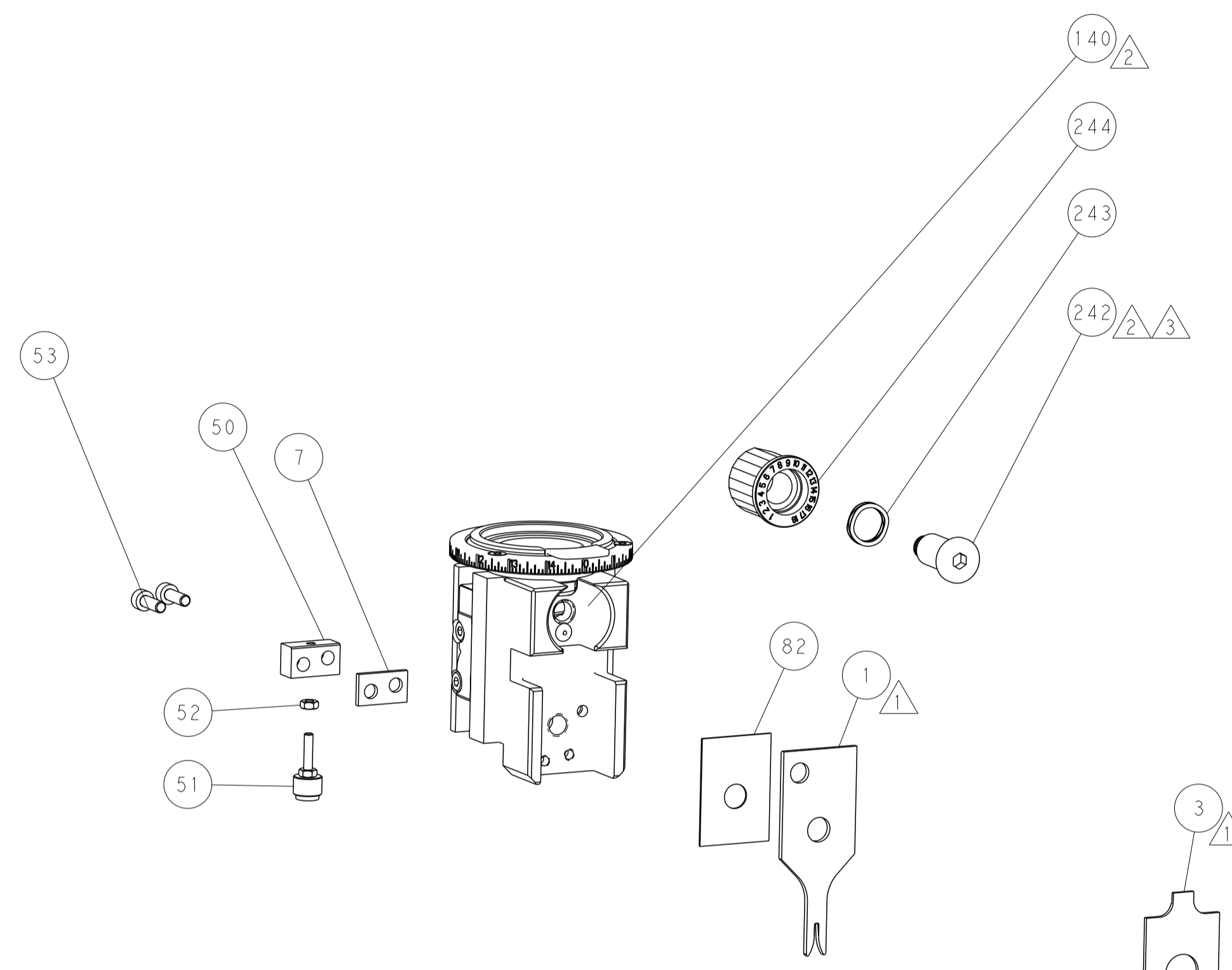
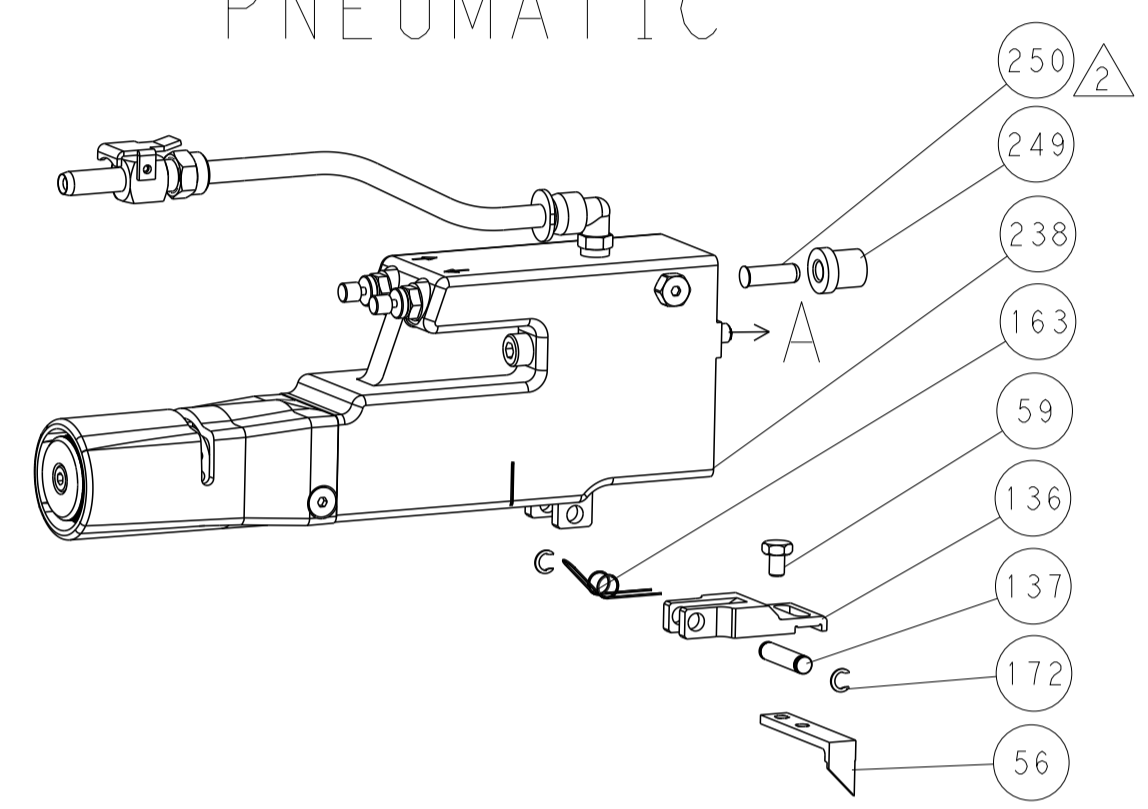

TERMINAL SUPPORT LOCATION

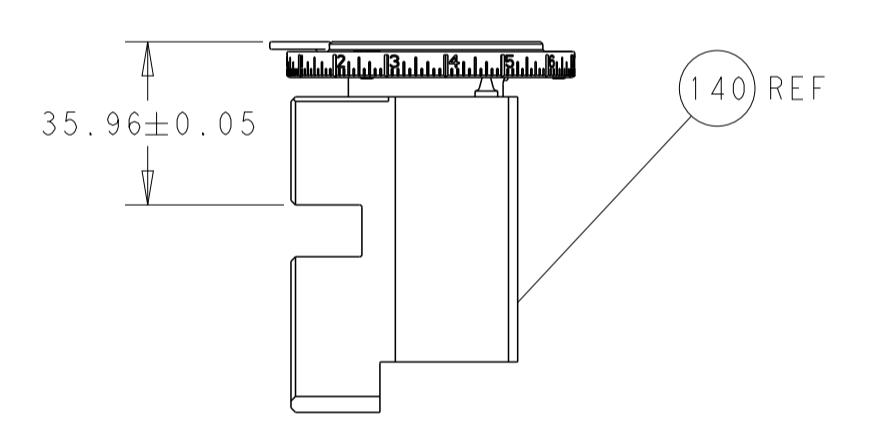
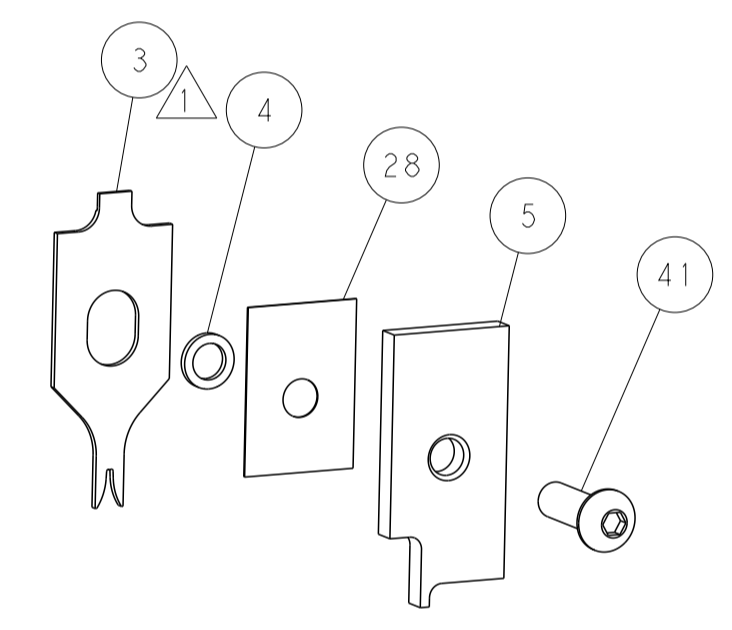

RAM SET-UP

CAM POSITIONS

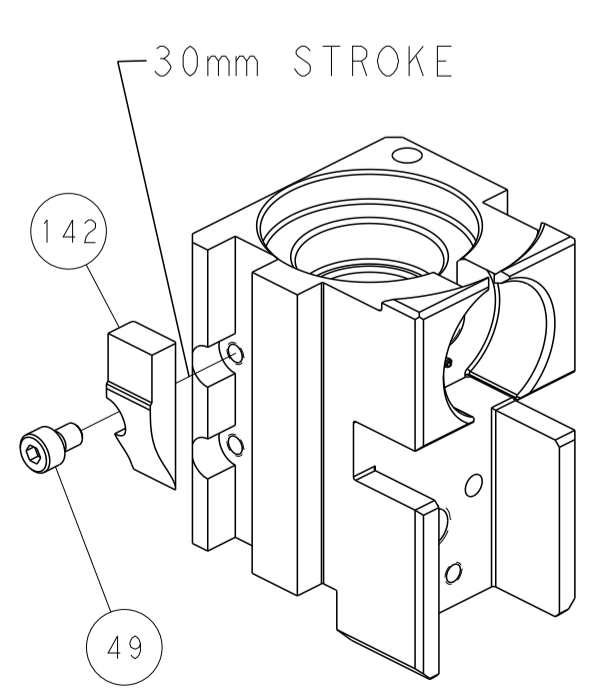

MECHANICAL
POST FEED

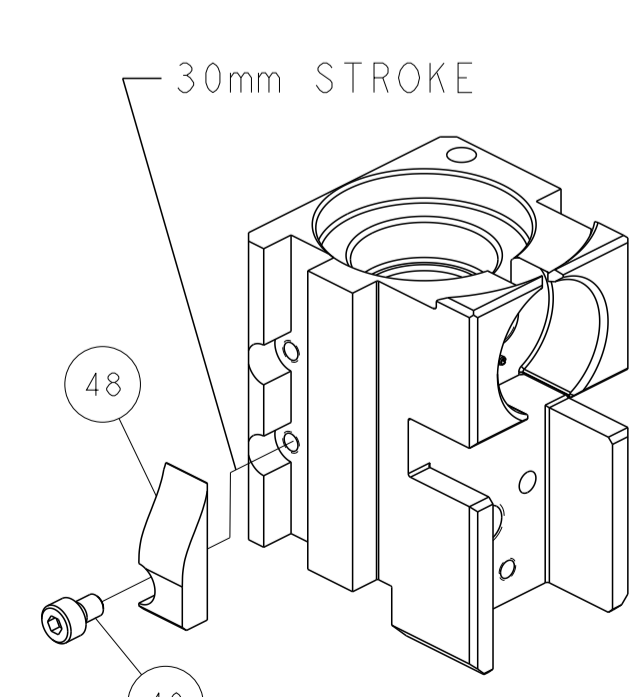

MECHANICAL
PRE FEED

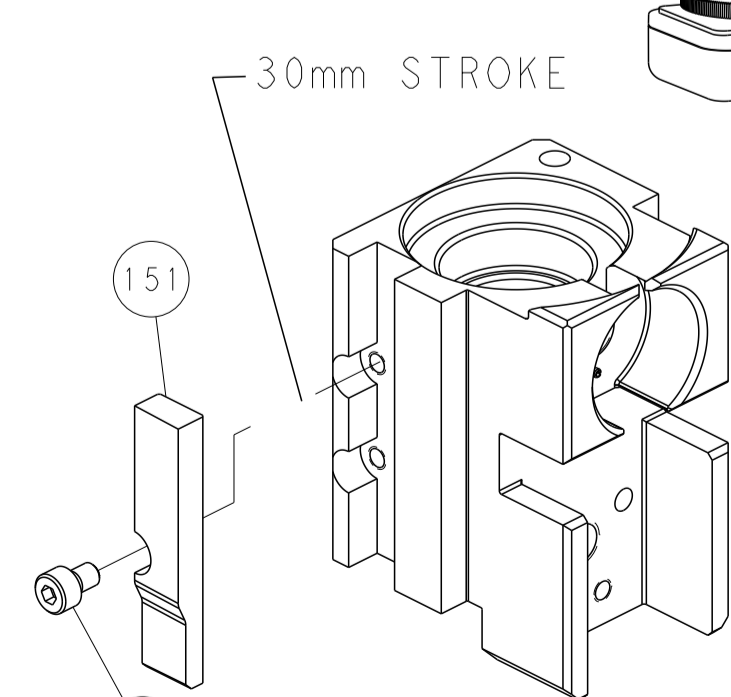

AIR FEED

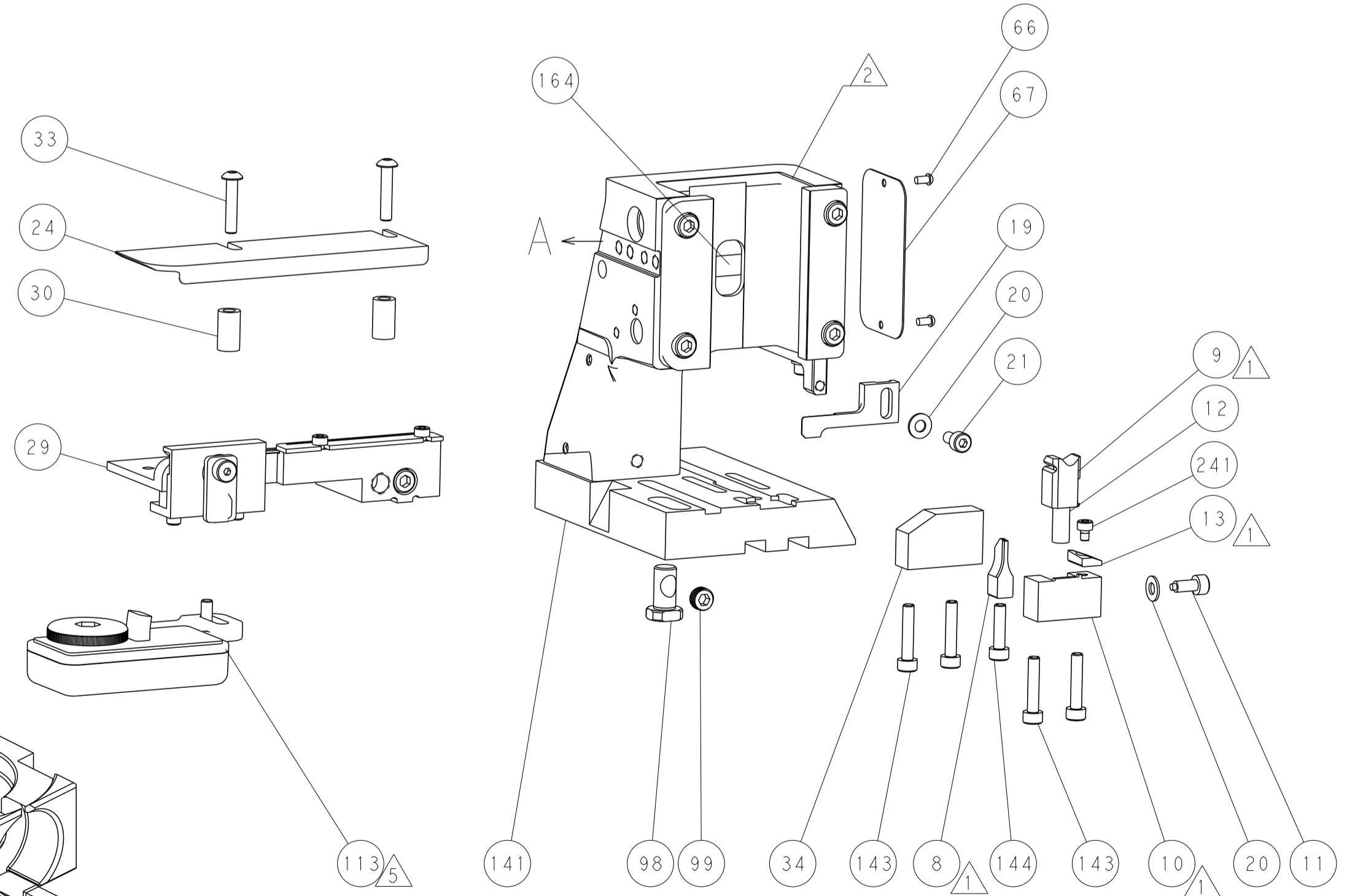

PACIFIC VERSION
 Shown on sheets 3 of 4 & 4 of 4
 (Atlantic version shown on sheets 1 of 4 & 2 of 4)

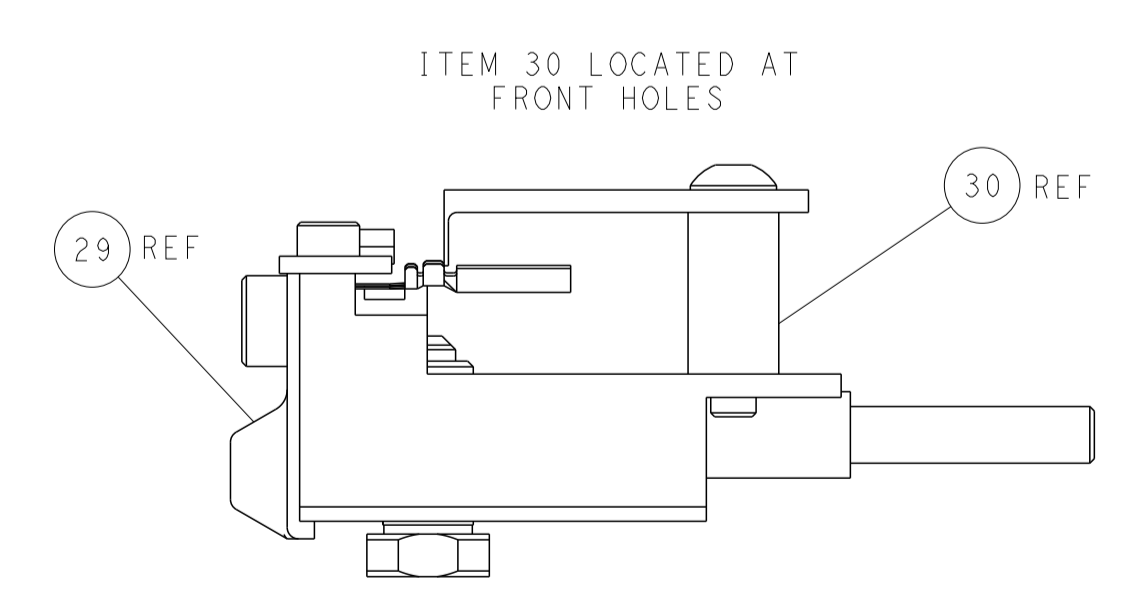

FEED TRACK POSITION
GUIDE BY WIRE BARREL

<small>THIS DRAWING IS UNPUBLISHED. RELEASED FOR PUBLICATION. ALL RIGHTS RESERVED. © 2000 BY TYCO ELECTRONICS CORPORATION. THIS DRAWING IS THE PROPERTY OF TYCO ELECTRONICS CORPORATION AND IS NOT TO BE REPRODUCED OR TRANSMITTED IN ANY FORM OR BY ANY MEANS, ELECTRONIC OR MECHANICAL, WITHOUT PERMISSION IN WRITING FROM TYCO ELECTRONICS CORPORATION.</small>		DWN X_ZHAO 12SEP2014 CHK T_ELFIN 12SEP2014 APVD JJ_GUO 12SEP2014	NAME Ocean Side Feed Applicator
DIMENSIONS: mm 	TOLERANCES UNLESS OTHERWISE SPECIFIED: 0 PLC ± 1 PLC ± 2 PLC ± 3 PLC ± 4 PLC ± ANGLES ± FINISH	PRODUCT SPEC APPLICATION SPEC WEIGHT SCALE 1:2	SIZE CAGE CODE DRAWING NO A1 00779 ©=2266505 SHEET 4 OF 4 REV B