

REVISIONS					
P	LTR	DESCRIPTION	DATE	DWN	APVD
L1		REVISED PER ECO-11-004820	11MAR11	RK	HMR
L2		REVISED PER ECO-18-017879	14NOV2018	RS	DR

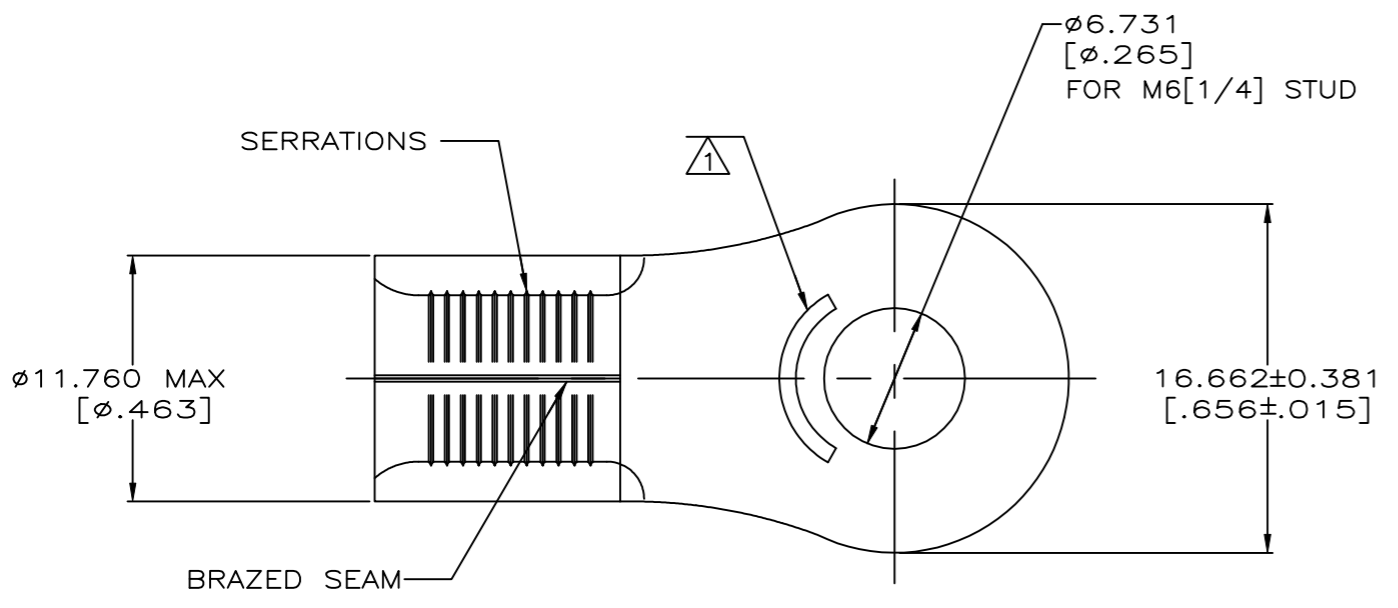

<b>AMP</b> WIRE RANGE	E13288 Listed
4 AWG SOLID OR STRANDED	4 AWG STRANDED
LR7189 Certified	MILITARY P/N AND CLASS
4 AWG SOLID OR STRANDED	NOT APPLICABLE

- ① STAMP AMP 4\* APPROX AS SHOWN
- ② TIN PLATE 0.00254[.000100] MIN EXT.  
THK TIN PER ASTM B545
- ③ UNPLATED/CLEANED.

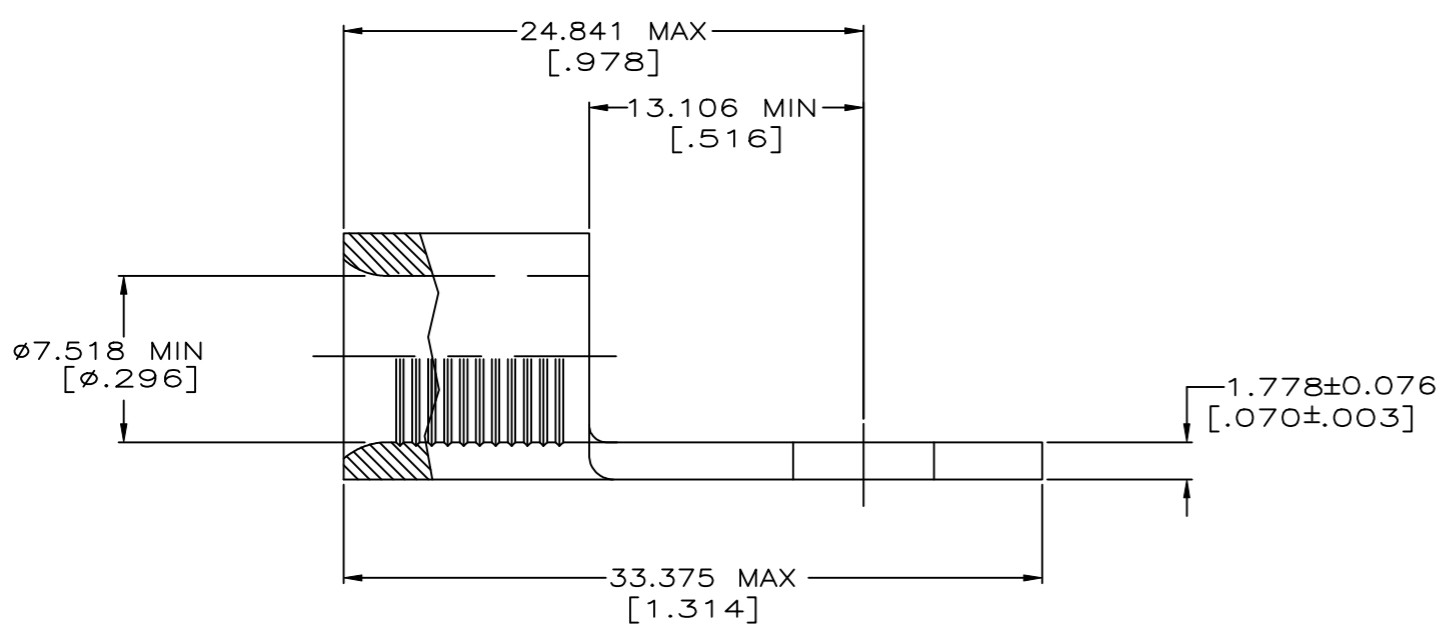

50	②	LOOSE PIECE, BOX	8-33469-2
500	②	ON TAPE, REEL	2-33469-4
100	③	LOOSE PIECE	33469-1
100	②	LOOSE PIECE	33469
QUANTITY	FINISH	PACKAGING TYPE	PART NO

<b>AMP INCORPORATED CUSTOMER SERVICE SYSTEMS</b>		MAX RECOMMENDED OPERATING TEMPERATURE: 170°C[338°F] MAX
FOR ADDITIONAL PRODUCT INFORMATION OR COPIES OF DRAWINGS AND TECHNICAL DOCUMENTS	PRODUCT INFORMATION CENTER 1-800-522-6752	VOLTAGE RATING: NOT APPLICABLE
FOR APPLICATION TOOLING INFORMATION	TOOLING ASSISTANCE CENTER 1-800-722-1111	WIRE CROSS SECTIONAL AREA RANGE: 16.8-26.7mm <sup>2</sup> [33,100-52,600] CIR MILS SOLID OR STRANDED
FOR ORDER ENTRY	1-800-526-5142	THIS DRAWING IS A CONTROLLED DOCUMENT FOR AMP INCORPORATED. IT IS SUBJECT TO CHANGE AND THE CONTROLLING ENGINEERING ORGANIZATION SHOULD BE CONTACTED FOR THE LATEST REVISION.

THIS DRAWING IS A CONTROLLED DOCUMENT.		DWN TA BRINKMAN 3-29-93	TE Connectivity	
DIMENSIONS: mm[INCHES]		CHK DA PATTERSON 3-29-93	NAME DE MILLER 3-29-93	
TOLERANCES UNLESS OTHERWISE SPECIFIED: 0 PLC ± - 1 PLC ± - 2 PLC ± - 3 PLC ± .127[0.005] 4 PLC ± - ANGLES ± -		APVD DE MILLER 3-29-93	PRODUCT SPEC UL 486 A-B	
MATERIAL COPPER PER ASTM B-152 ANNEALED		FINISH SEE TABLE	APPLICATION SPEC -	SIZE A2
		WEIGHT -	CAGE CODE 00779	DRAWING NO C-33469
		CUSTOMER DRAWING		RESTRICTED TO -
		SCALE 4:1	SHEET 1 of 1	REV L2