

T-960

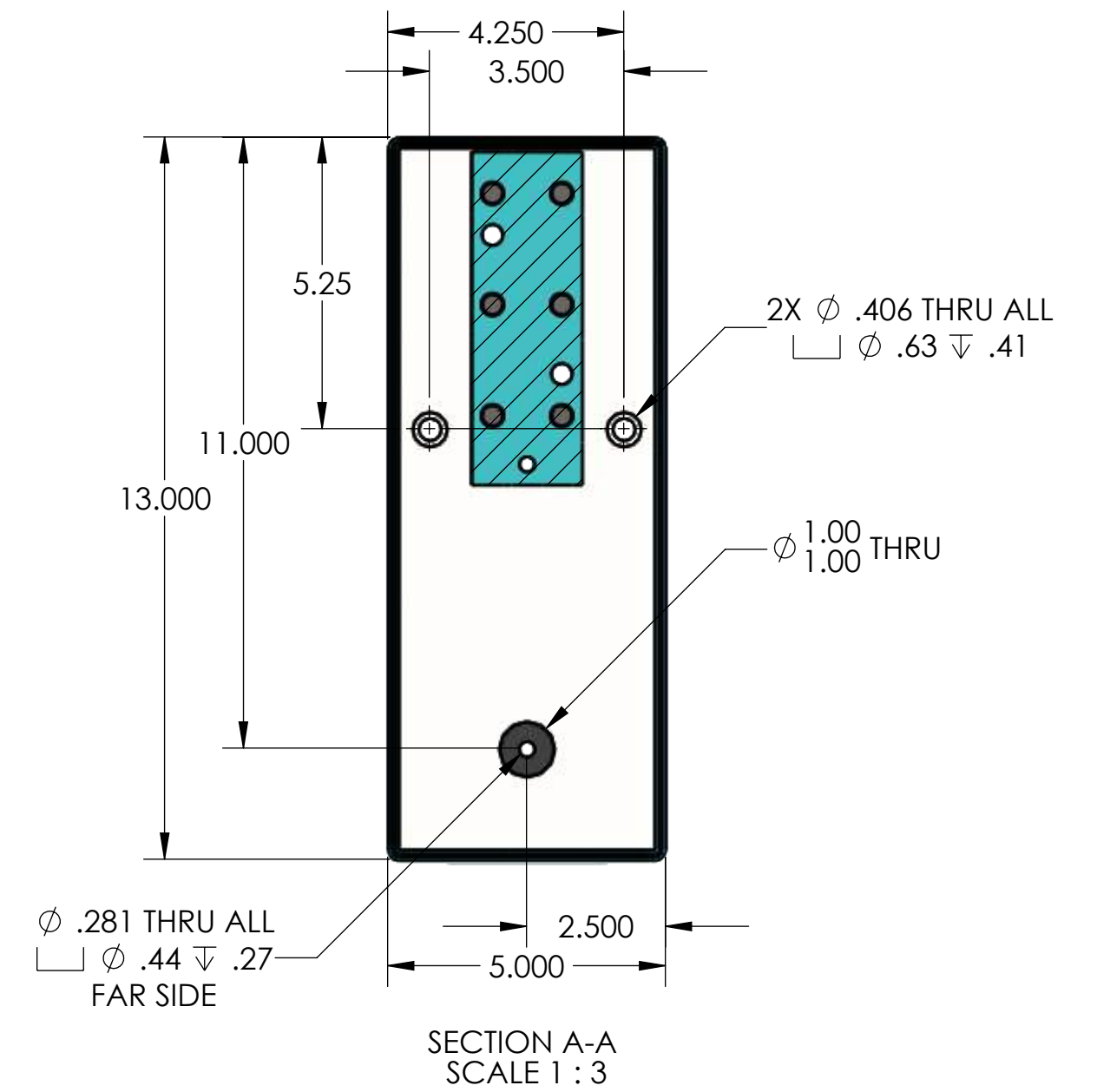
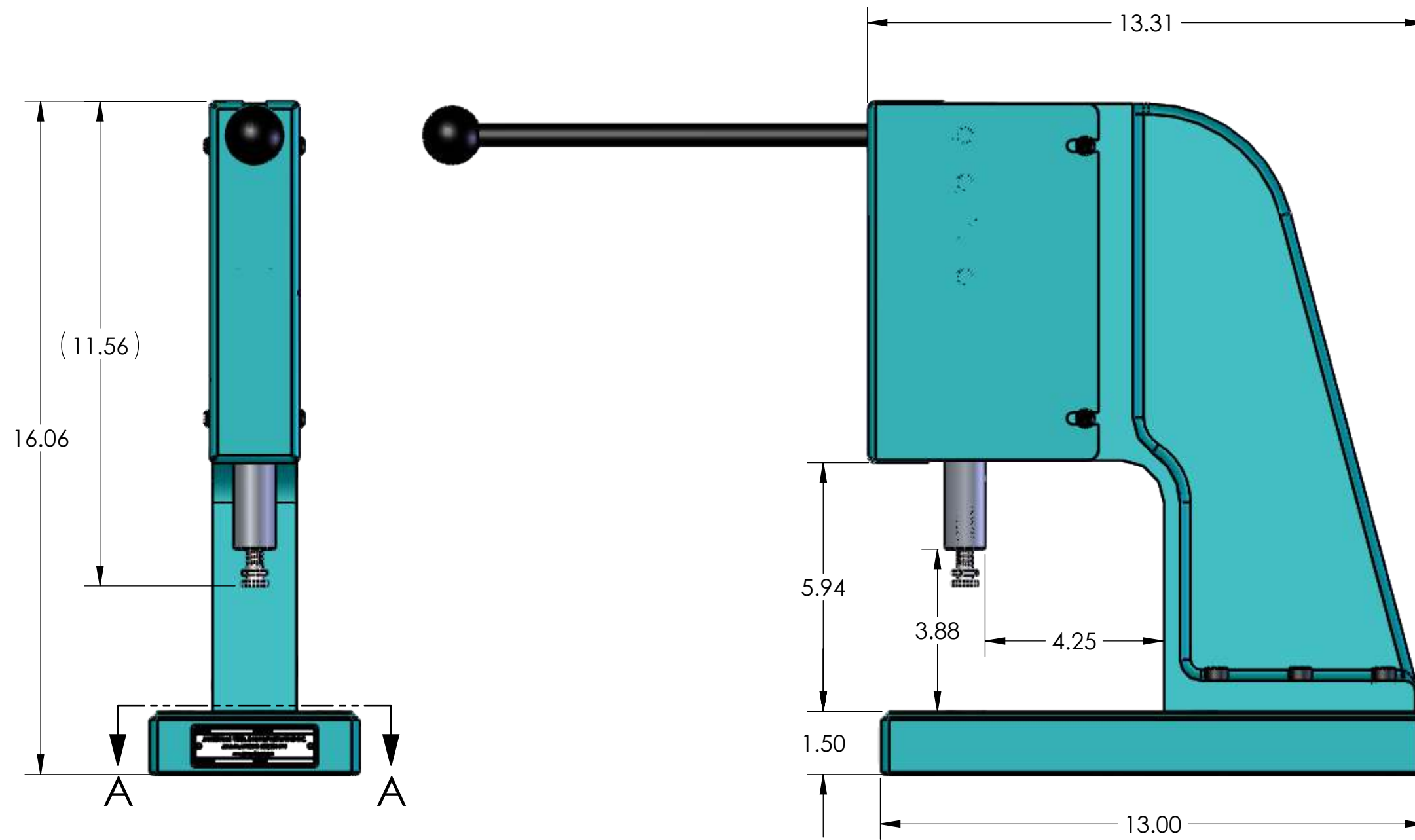

SECTION A-A  
SCALE 1 : 3

NOTE:

- 1. T-960 IS SHOWN WITH THE ATTACHMENT OPTION (-A)

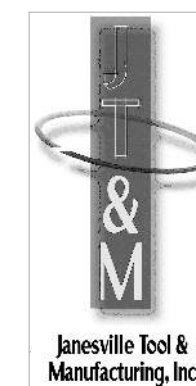

**Janesville Tool & Manufacturing Inc.**  
 3930 Enterprise Drive  
 Janesville, WI 53546  
 Phone: 608-314-1620, Fax 608-314-1625

TITLE: **TOGGLE SERIES**

SIZE	DWG. NO.	REV
<b>C</b>	T-960	
SCALE: 1:4		WEIGHT: 53.62
		SHEET 1 OF 1