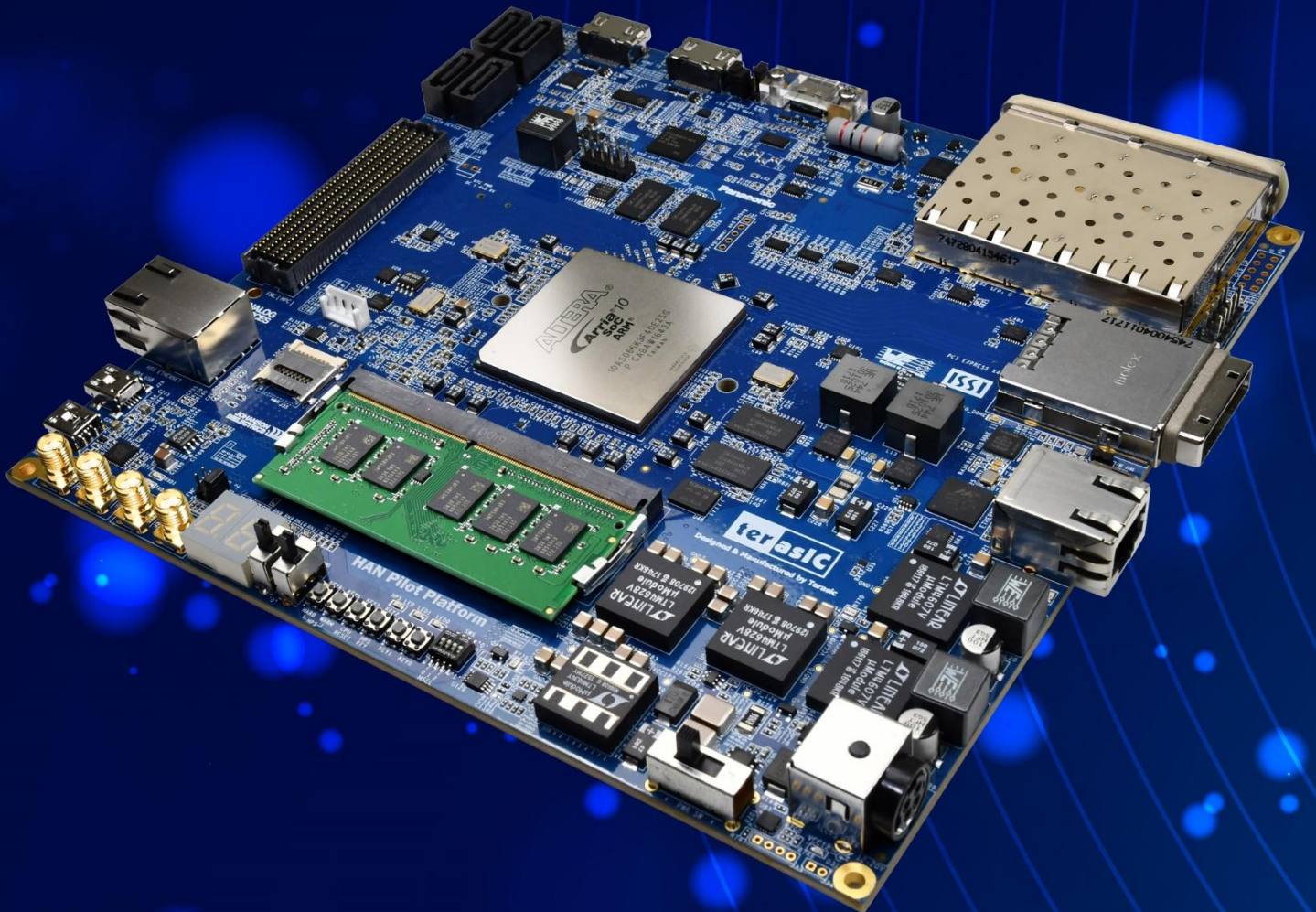


# ***HAN Pilot Platform***

## **HARDWARE MANUAL**



# TABLE OF CONTENTS

<b>Chapter 1</b>	<b>Overview</b> .....	<b>3</b>
1.1	The Package Contents .....	3
1.2	HAN Pilot Platform System CD.....	4
1.3	Getting Help .....	4
<b>Chapter 2</b>	<b>Board Components</b> .....	<b>5</b>
2.1	Components and Layout.....	5
2.2	Block Diagram.....	8
<b>Chapter 3</b>	<b>Board Settings and Status Component</b> .....	<b>10</b>
3.1	Board Setting Switches.....	10
3.2	Board Setting Headers .....	11
3.3	Status LED.....	14
3.4	JTAG Interface .....	16
<b>Chapter 4</b>	<b>FPGA Fabric Components</b> .....	<b>17</b>
4.1	User Interface (LED/7-SEG/Button/Switch).....	17
4.2	USB Type-C Port.....	19
4.3	SFP+ Connector.....	24
4.4	SATA .....	27
4.5	PCIe .....	30
4.6	DDR4.....	32
4.7	HDMI Transmitter and Receiver .....	41
4.8	Gigabit Ethernet.....	43
4.9	FMC Connector .....	44
4.10	Temperature Sensor, Fan Control and Power Monitor .....	53
4.11	Gyroscope, Accelerometer and Magnetometer.....	54
<b>Chapter 5</b>	<b>HPS Fabric Components</b> .....	<b>57</b>
5.1	User Push-buttons and LEDs.....	57

5.2 Gigabit Ethernet.....	57
5.3 UART to USB.....	59
5.4 Micro SD Card Socket.....	60
5.5 USB OTG .....	60
5.6 GPIO Header .....	61
5.7 DDR4 (HPS).....	62
<b>Chapter 6      System Clocks .....</b>	<b>67</b>
<b>Chapter 7      Power.....</b>	<b>70</b>
<b>Chapter 8      HAN Pilot Platform System Builder .....</b>	<b>71</b>
8.1 Introduction .....	71
8.2 General Design Flow .....	71
8.3 Using HAN Pilot Platform System Builder.....	72
<b>Chapter 9      Appendix.....</b>	<b>80</b>

# Chapter 1

## Overview

The HAN Pilot Platform provides users a combination of ARM software and FPGA hardware development platforms. It has a vast memory device and peripherals on the hardware. This kit also includes resourceful reference designs to help users to accomplish their design needs. The hardware offers in the HAN Pilot Platform has the maximum capacity with 660K LEs in Arria 10 SoC FPGA and featuring various types of high-speed image interface such as: HDMI, Display Port, and 12G-SDI and a large capacity of DDR4 memory. The board's high speed network interface, Gigabit Ethernet and SFP+10GbE, provides hardware resources for network communications related applications.

The HPS can be reboot with MicroSD Card. The FPGA on the main board can be connected to DDR4-SODIMM Socket in addition to the DDR4 memory module. The FPGA on the main board can also be connected to the Terasic QDR Memory Module as well. Beside the DDR4 memory module, you can also directly connect to the FPGA on the main board via the High Pin Count FMC expansion port to expand variety of functions.

The PCIe Gen3 x4 Connector interface comes with the Terasic PCA PCIe and PCIe Cable, which can be used to connect the Host PC to allow data between the FPGA and the Host PC. The USB Type-C interface on the motherboard allows the motherboard to obtain power for the host PC. The Host PC displays information and images through the high-speed transmission USB 3.0 or the Display Port.

### 1.1 The Package Contents

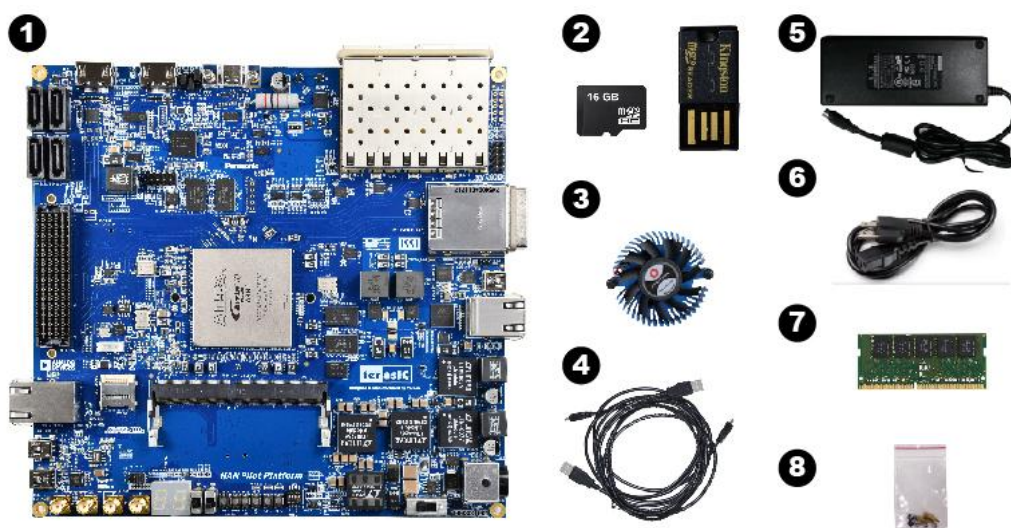


Figure 1-1 Package Contents



1. HAN Pilot Platform Kit
2. MicroSD Card (Installed) and Card Reader
3. Fan (Installed)
4. Two Type A to Mini-B USB Cables
5. 12V DC Power Supply (Installed)
6. AC Power Cord (USA)
7. One 4GB DDR4 ECC SO-DIMM Module (Installed)
8. Screws, Copper Stands, and Silicon Footstands

## **1.2 HAN Pilot Platform System CD**

The HAN Pilot Platform System CD contains all the documents and supporting materials associated with HAN Pilot Platform, including the user manual, system builder, reference designs and device datasheets.

Users can download this system CD from the link: <http://HAN Pilot Platform.terasic.com/cd>.

## **1.3 Getting Help**

Here are the addresses where you can get help if you encounter any problems:

- Terasic Technologies
- 9F., No.176, Sec.2, Gongdao 5th Rd, East Dist, Hsinchu City, 30070. Taiwan
- Email: [support@terasic.com](mailto:support@terasic.com)
- Tel.: +886-3-575-0880
- Website: [HAN Pilot Platform.terasic.com](http://HAN Pilot Platform.terasic.com)

## Board Components

This chapter provides an introduction to the features and design characteristics of the board.

### 2.1 Components and Layout

Figure 2-1 and Figure 2-2 shows a photograph of the board. It depicts the layout of the board and indicates the location of the connectors and key components.

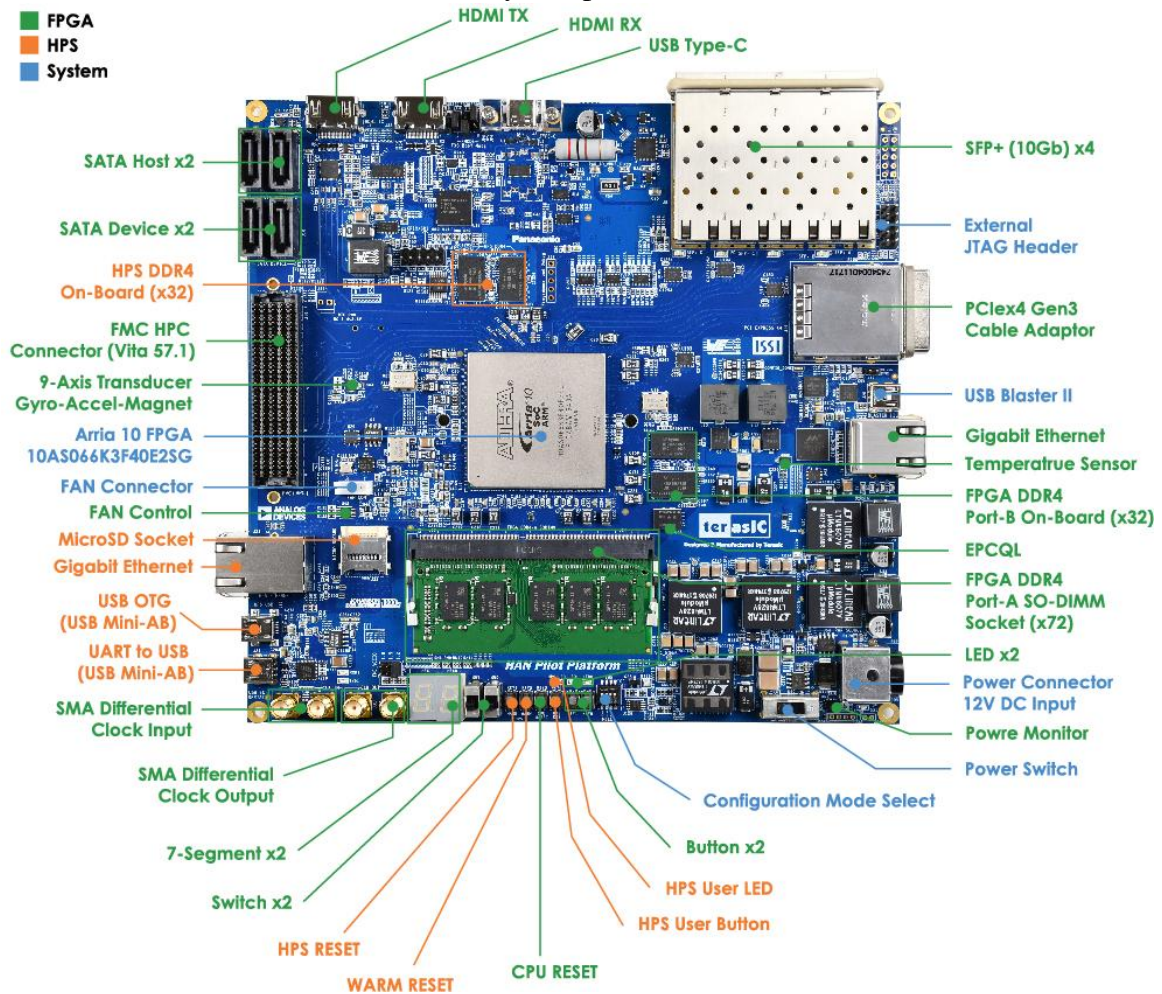
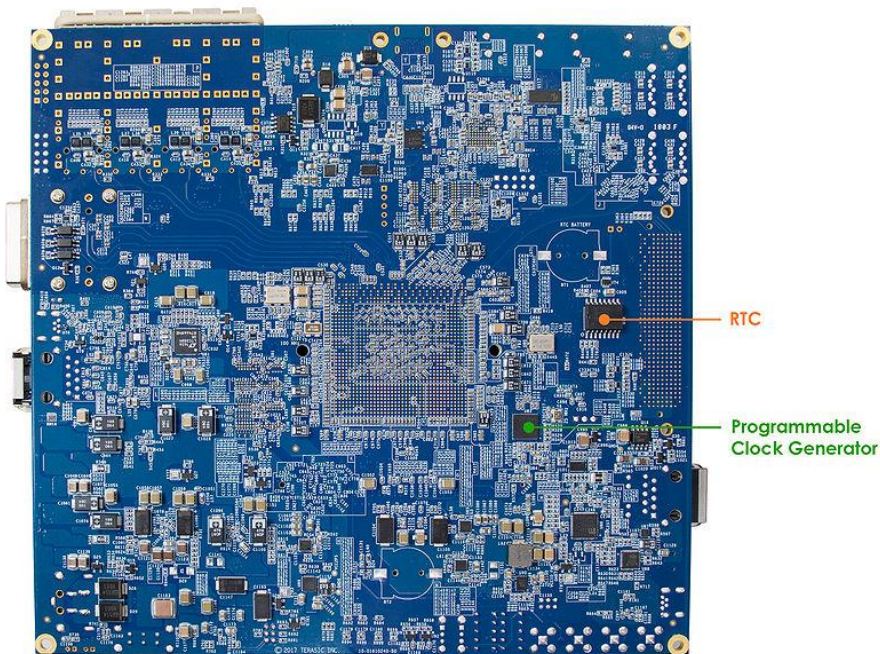


Figure 2-1 HAN Pilot Platform (top view)



**Figure 2-2 HAN Pilot Platform (bottom view)**

The HAN Pilot Platform has many features that allow users to implement a wide range of designed circuits, from simple circuits to various multimedia projects.

The following hardware are provided on the board:

- FPGA Device
  - Intel ® Arria10® SoC 10AS066K3F40E2SG device (660K LEs)
  - USB-Blaster II onboard for programming; JTAG Mode
  - Serial configuration device – EPCQL1024
  - One DDR4 SO-DIMM Socket, support ECC
  - On-board 1GB DDR4-2400, 32-bit data width
  - USB Type-C Interface
    - Power Delivery
    - DisplayPort TX/RX with 4 lanes
    - USB 3.0/2.0
  - HDMI TX/RX 2.0 for 4K2K@60- FPGA Transceiver

- PCIe Cabling Socket at Gen3 x4
- SFP+ Socket x4, 40Gbps
- SATA 3.0 Host and SATA Device x2 (SATA Connector x4)
- One Gigabit Ethernet Port
- SMA Clock-In and Clock-Out
- High Pin Count FMC Connector. Partial pin levels are adjustable (Support VADJ 1.2V/1.5V/1.8V)
- Accelerometer, Gyroscope and Magnetometer
- Temperature Sensor
- Fan Control
- LED x2, KEY x2, Switch x2, 7-Segment x2
- HPS (Hard Processor System)
  - 1.5GHz Dual-core ARM Cortex-A9 processor
  - MicroSD Card Socket
  - On-board 1GB DDR4-2400, 32-bit data width
  - 1 Gigabit Ethernet PHY with RJ45 connector
  - USB OTG Port, USB mini-AB connector
  - UART to USB, USB Mini-B connector
  - RTC
  - One user button and one user LED
  - Warm reset button and cold reset button



## 2.2 Block Diagram

**Figure 2-3** is the block diagram of the board. All the connections are established through the Arria 10 SoC FPGA device to provide maximum flexibility for users. Users can configure the FPGA to implement any system design.

Detailed information about **Figure 2-3** are listed below.

- Arria 10 SoC 10AS066K3F40E2SG/10AS057K3F40E2SG FPGA
  - Dual-core ARM Cortex-A9 (HPS)
  - 660K programmable logic elements
  - 42,660 Kbits embedded memory
  - Hard memory controllers x5
  - Transceivers x48(17.4 Gbps)
  - 18-bit x 19-bit multipliers x3,356
  - Accelerometer & Gyroscope Device MPU9250
- Configuration
  - EPCQ1024L Serial Configuration Device
  - Onboard USB-Blaster II (Mini-B USB connector)
- Memory Device
  - On-board 1GB DDR4-2400, 32-bit data width
  - Two DDR4 SO-DIMM SDRAM socket
  - Micro SD card socket
- Communication
  - USB OTG (Mini-AB USB connector)
  - UART-to-USB (Mini-B USB Connector)
  - Giga Ethernet x2
  - PCIe Gen3 x4 Cabling Socket
- Expansion Ports
  - FMC connector
    - one HPC (high-pin count) FMC connector with xcvr
    - Partial pin levels are adjustable, VADJ:1.2V/1.5V/1.8V
- Multimedia Interface
  - HDMI TX and RX ports
- Clock
  - Two SMA connectors for SMA Clock-In and Clock-Out
  - On-board PLLs
- General user input/output
  - Buttons x3 (FPGA x2, HPS x1)
  - Switches x2 on FPGA
  - LEDs x3 (FPGA x2, HPS x1)
  - 7-segment displays x2
- System Monitor and Control
  - Temperature Sensor on FPGA
  - 12V Power Monitor
  - Power Controller

- I2C Fan Control
- Power
  - 12V DC input

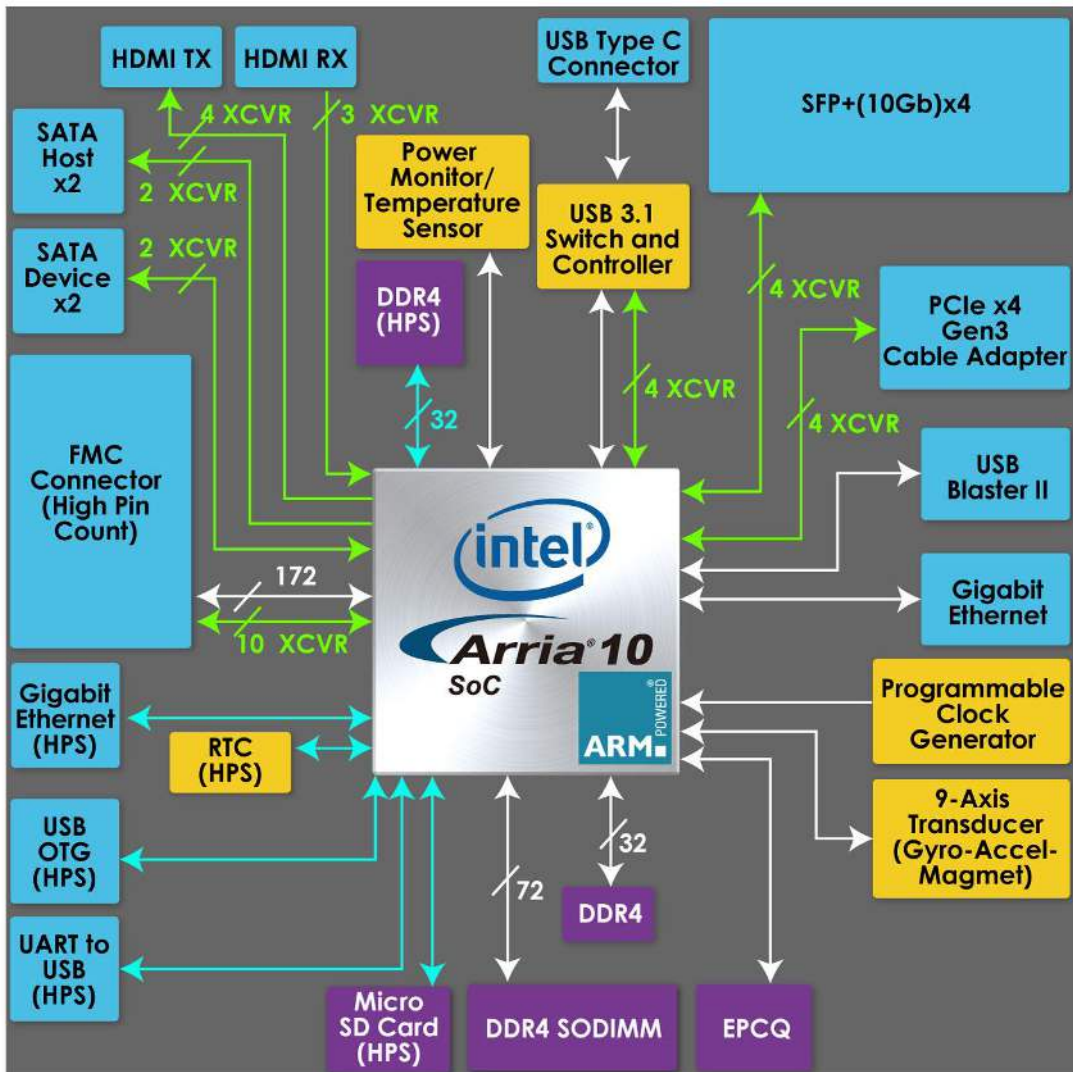


Figure 2-3 Block diagram of HAN Pilot Platform

# *Board Settings and Status*

## *Component*

---

This chapter describes all the setting devices on HAN Pilot Platform board and their functions, such as Switches and Headers. We also will describe the function of some status LEDs. The JTAG interface will be described at the end of this chapter.

### 3.1 Board Setting Switches

#### ■ Mode Select Switches

Mode Select Switch (SW5) is used to set the HAN Pilot Platform FPGA MSEL pin value. These MSEL pins determined the Configuration Mode of the FPGA.

**Table 3-1** list the MSEL setting for configuration scheme of FPGA, when MSEL is set to AS mode (Factory default setting), FPGA will be booted from EPCQ device (See **Figure 3-1**). When MSEL is set to FPP mode (See **Figure 3-2**), FPGA can be configured by HPS Fabric (From Micro SD Card).

**Table 3-1 MSEL setting for configuration scheme of FPGA**

Configuration Scheme	SW5 MSEL[2..0] Setting	Description
AS Mode (Factory Default)	010	FPGA boot from EPCQ
FPP Mode	000	FPGA boot from Micro SD Card

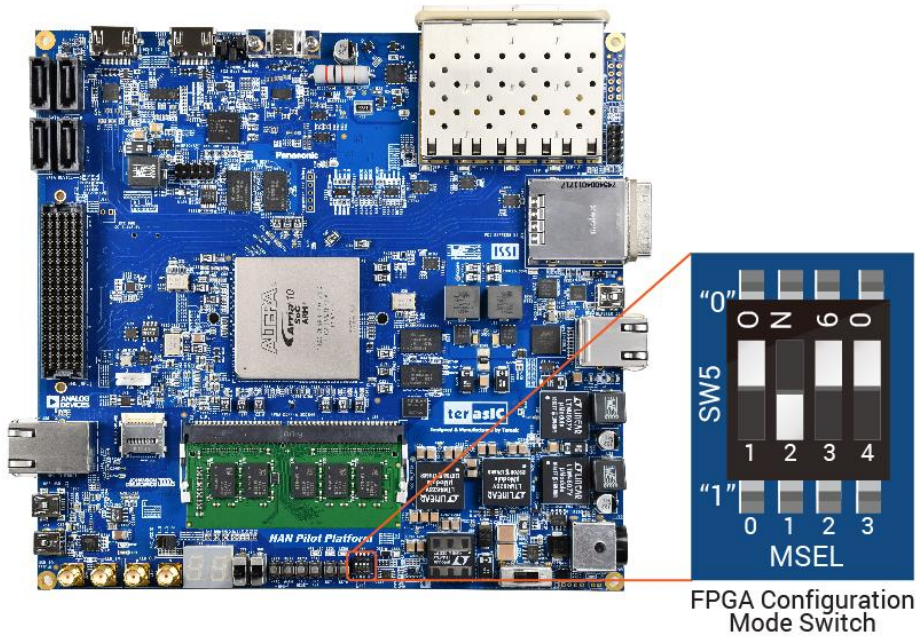


Figure 3-1 The AS mode setting of SW5

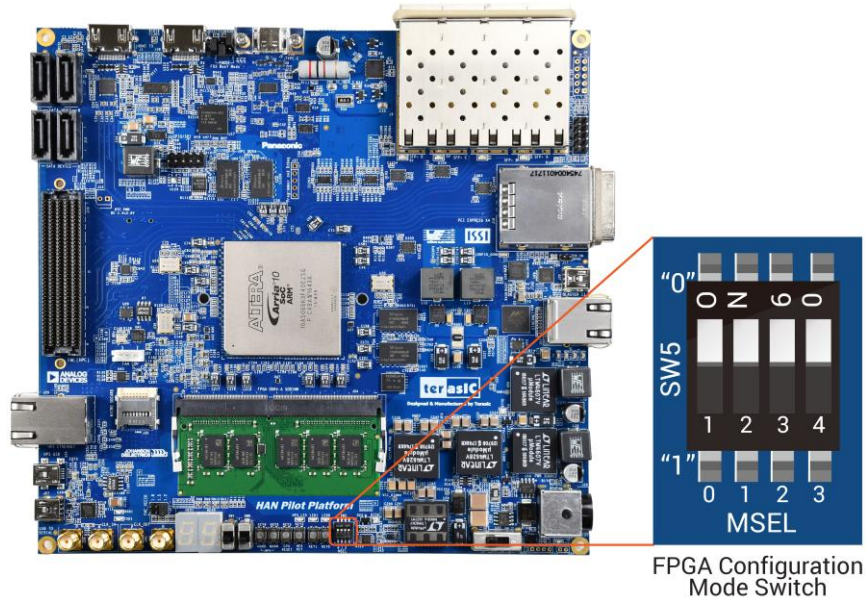


Figure 3-2 The FPP mode setting of SW5

## 3.2 Board Setting Headers

### ■ JTAG Interface Header

J17 is the header used to set the JTAG bus of FMC connector connect to JTAG interface of HAN Pilot Platform system. The FMC connector will not be included in the JTAG chain if the headers are set to open (See Figure 3-3). Table 3-2 list the setting of the J17 header.

Table 3-2 JTAG Interface Headers Setting

Header	Setting	Descriptions
--------	---------	--------------



J17	Open (Default Setting)	Disable the JTAG interface of the FMC connector into the JTAG chain
	Connected	Enable the JTAG interface of the FMC connector into the JTAG chain, user need set a Jtag loop circuit on FMC daughter card

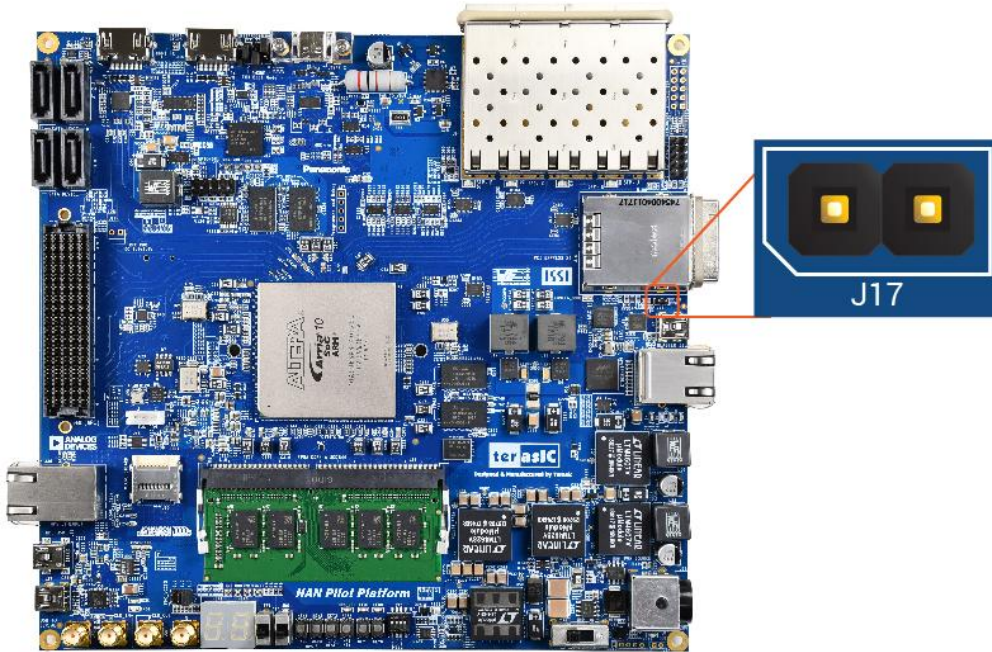


Figure 3-3 The FMC JTAG Header

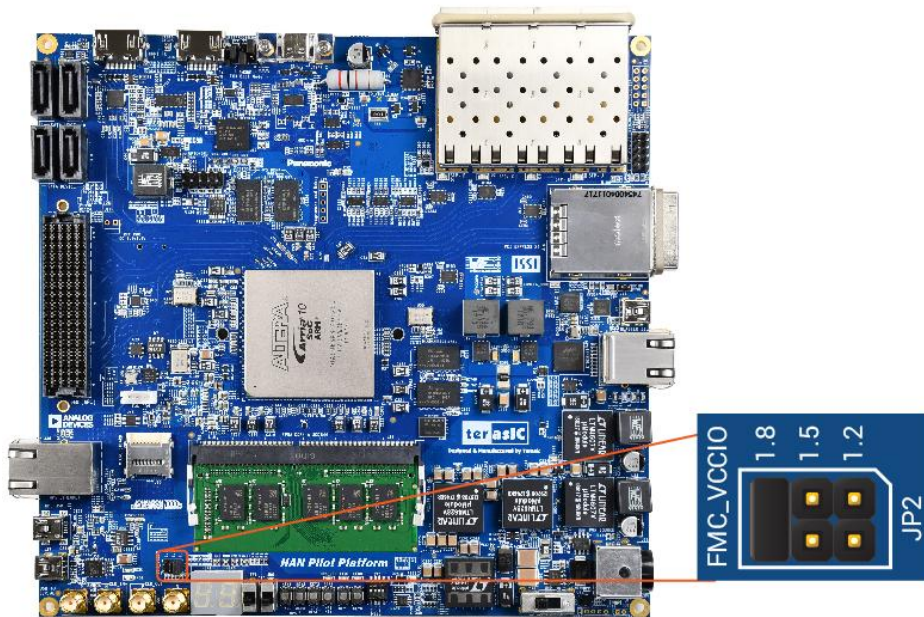
■ **FMC\_VCCIO Select Header**

JP2 is used to set the VCCIO voltage of FPGA I/O on FMC connector, as FMC partial pin levels are adjustable ( 1.2V/1.5V/1.8V ), the FMC connector can support various I/O standard FMC daughtercards. **Table 3-3** list the FMC\_VCCIO Headers Setting.

Table 3-3 FMC\_VCCIO Headers Setting

JP2 Setting	FMC VCCIO Voltage
	1.2V

	1.5V
	1.8V (Default Setting)



**Figure 3-4 The FMC VCCIO select header**

■ **PMODE Select Header**

The USB 3.0 Controller (Cypress FX3) on the HAN Pilot Platform can be booted from the different sources, selected by the configuration of the PMODE header (JP4/JP5/JP6) on HAN Pilot Platform. **Table 3-4** shows the boot options and associated settings. The default boot device is the from a serial flash via SPI interface.

**Table 3-4 PMODE Headers Setting**

PMODE [2:0] (JP6/JP5/JP4) Setting	Boot Source
F00	Sync ADMux (16-bit)
F01	Async ADMux (16-bit)
F11	USB boot
F0F	Async SRAM (16-bit)
F1F	I2C, On Failure, USB Boot is Enabled

1FF	I2C only
0F1(Default)	SPI, On Failure, USB Boot is Enabled

Note: F indicates Floating

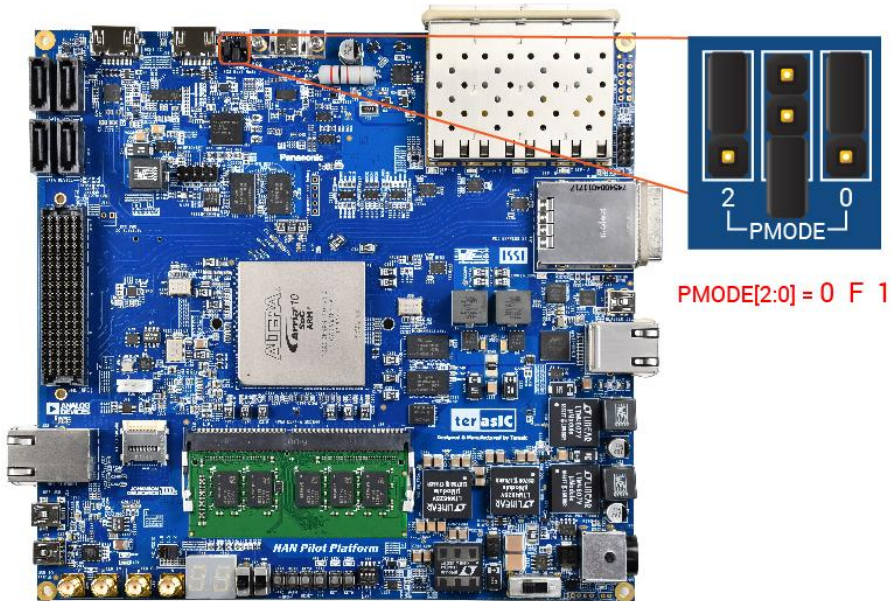


Figure 3-5 The PMODE select header

### 3.3 Status LED

This section describes the all status LED for the interfaces on HAN Pilot Platform board. **Figure 3-6** shows all the status LED on the HAN Pilot Platform. Following are the detailed descriptions of these interface LED.

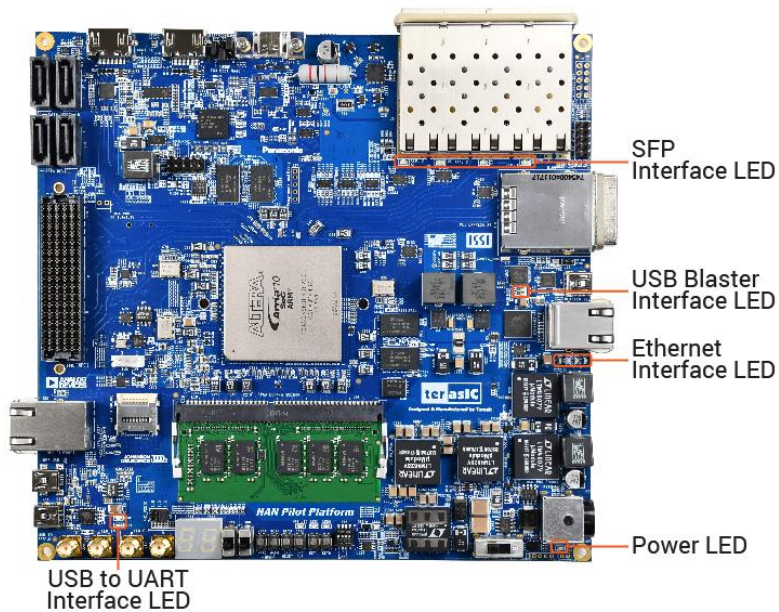


Figure 3-6 The status LED on the HAN Pilot Platform board



## ■ UART Interface

Table 3-5 list the two status LEDs for UART interface.

**Table 3-5 Status LED for UART Interface**

Component	Reference	Status	Descriptions
TXD1	UART_TXD	ON	Transmitting
RXD1	UART_RXD	ON	Receiving

## ■ SFP Interface

Table 3-6 list the four status LEDs for SFP interface.

**Table 3-6 Indicator LED for SFP Interface**

Component	Reference	Status	Descriptions
D4	SFPA_MOD0_PRSENT_n	ON	Indicate that the SFP module is present on the SFPA
D3	SFPB_MOD0_PRSENT_n	ON	Indicate that the SFP module is present on the SFPB
D2	SFPC_MOD0_PRSENT_n	ON	Indicate that the SFP module is present on the SFPC
D1	SFPD_MOD0_PRSENT_n	ON	Indicate that the SFP module is present on the SFPD

## ■ Ethernet Interface

Table 3-7 list the four status LEDs for Ethernet interface.

**Table 3-7 Status LED for Ethernet Interface**

Component	Reference	Status	Descriptions
D8	ETH_LED_TX	ON	Transmitting
D9	ETH_LED_RX	ON	Receiving
D10	ETH_LINK1000	ON	1000Mbps Link UP
D11	ETH_LINK100	ON	100Mbps Link UP

## ■ Power

Table 3-8 list the two status LEDs for power.

**Table 3-8 Status LED for Power**

Component	Reference	Status	Descriptions
D31	12V~20V Power Indicator	ON	Illuminates when 12V~20V Power Supply is active



## ■ USB Blaster

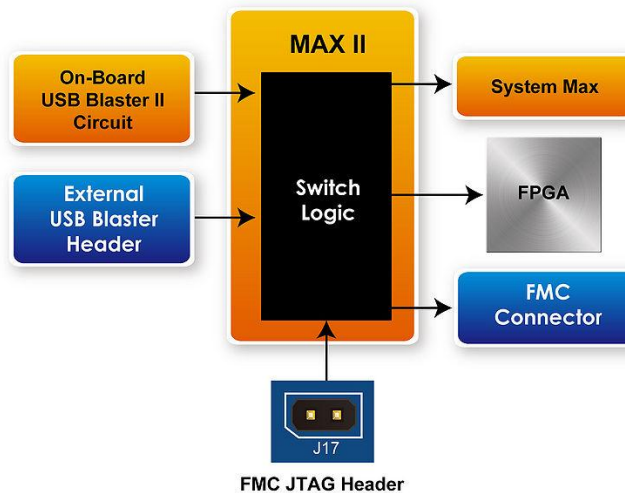
Table 3-9 list the two status LEDs for USB Blaster interface.

**Table 3-9 Status LED for USB Blaster Interface**

Component	Reference	Status	Descriptions
D5	JTAG_TX	ON	Illuminates when JTAG interface is transmitting data
D6	JTAG_RX	ON	Illuminates when JTAG interface is receiving data

## 3.4 JTAG Interface

Figure 3-7 shows the JTAG interface of HAN Pilot Platform. Users can access to the JTAG interface through the USB Blaster II circuit or connect external blaster to external blaster header. All the devices which implement JTAG are connect to MAX II device, and switch via MAX II internal switch logic. By using headers J17, users can include FMC connector JTAG interface in the HAN Pilot Platform JTAG Chain, or exclude them from the JTAG Chain. The default JTAG path for HAN Pilot Platform is: USB Blaster II ==> HPS ==> FPGA ==> (Bypass FMC connector) ==> USB Blaster II. When the External JTAG connector is connected to the external blaster, the On board's USB blaster II function will be replaced by the external blaster.

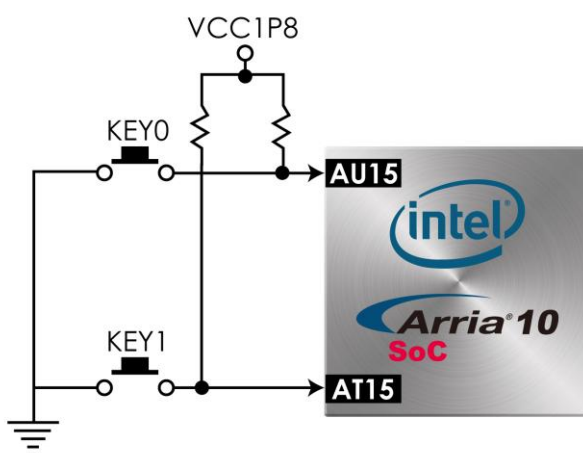


**Figure 3-7 JTAG interface of HAN Pilot Platform**

# FPGA Fabric Components

## 4.1 User Interface (LED/7-SEG/Button/Switch)

The board has two push-buttons connected to the FPGA, as shown in **Figure 4-1**. The two push-buttons named KEY0 and KEY1 are connected directly to the Arria 10 SoC FPGA. **Table 4-1** list the pin assignment of user push-buttons.

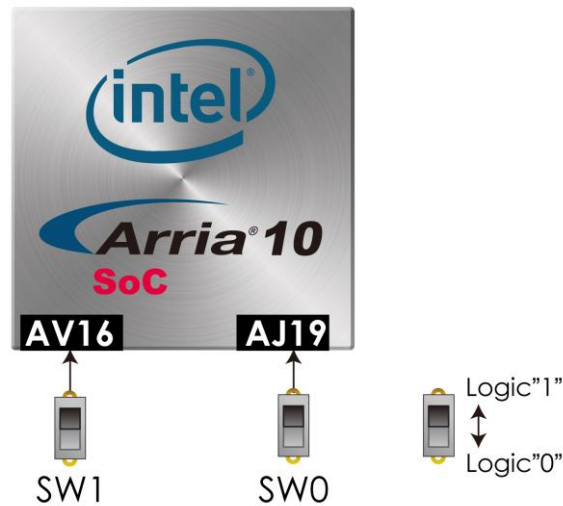


**Figure 4-1** Connections between the push-buttons and the Arria 10 SoC FPGA

**Table 4-1** Pin Assignment of Push-buttons

Signal Name	FPGA Pin Number	Description	I/O Standard
KEY[0]	PIN_AU15	Push-button[0]	1.8V
KEY[1]	PIN_AT15	Push-button[1]	1.8V
CPU_RESET_n	PIN_AN18	CPU_RESET button	1.8V

There are two slide switches connected to the FPGA, as shown in **Figure 4-2**. These switches are not debounced and to be used as level-sensitive data inputs to a circuit. Each switch is connected directly and individually to the FPGA. When the switch is set to the DOWN position (towards the edge of the board), it generates a low logic level to the FPGA. When the switch is set to the UP position, a high logic level is generated to the FPGA. **Table 4-2** list the pin assignment of switches.

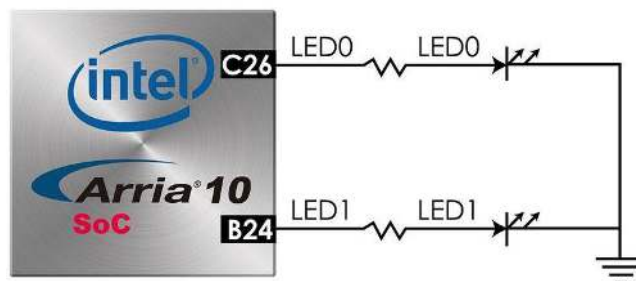


**Figure 4-2 Connections between the switches and the Arria 10 SoC FPGA**

**Table 4-2 Pin Assignment of Switches**

Signal Name	FPGA Pin Number	Description	I/O Standard
SW[0]	PIN_AJ19	Slide Switch[0]	1.8 V
SW[1]	PIN_AV16	Slide Switch[1]	1.8 V

There are also two user-controllable LEDs connected to the FPGA. Each LED is driven directly and individually by the Arria 10 SoC FPGA; driving its associated pin to a high logic level or low level to turn the LED on or off, respectively. **Figure 4-3** shows the connections between LEDs and Arria 10 SoC FPGA. **Table 4-3** list the pin assignment of LEDs.



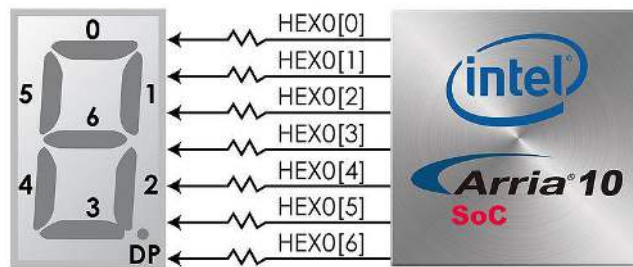
**Figure 4-3 Connections between the LEDs and the Arria 10 SoC FPGA**

**Table 4-3 Pin Assignment of LEDs**

Signal Name	FPGA Pin Number	Description	I/O Standard
LEDG[0]	PIN_C26	LED [0]	1.8 V
LEDG[1]	PIN_B24	LED [1]	1.8 V

The DE10-Advanced board has two 7-segment displays. These displays are paired to display numbers in various sizes. **Figure 4-4** shows the connection of seven segments (common anode) to pins on Arria 10 SoC FPGA. The segment can be turned on or off by applying a low logic level or high logic level from the FPGA, respectively. Each segment in a display is indexed from 0 to 6,

with corresponding positions given in **Figure 4-4**. **Table 4-4** shows the pin assignment of FPGA to the 7-segment displays.



**Figure 4-4** Connections between the 7-segment and the Arria 10 SoC FPGA

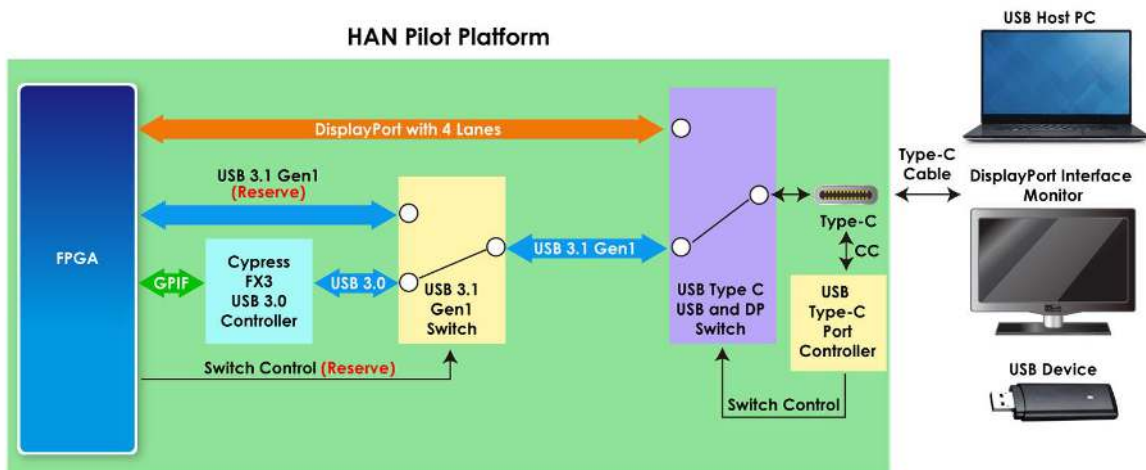
**Table 4-4** Pin Assignment of 7-segment

Signal Name	FPGA Pin Number	Description	I/O Standard
HEX0[0]	PIN_AT32	Seven Segment Digit 0[0]	1.8V
HEX0[1]	PIN_AR32	Seven Segment Digit 0[1]	1.8V
HEX0[2]	PIN_AU32	Seven Segment Digit 0[2]	1.8V
HEX0[3]	PIN_AU30	Seven Segment Digit 0[3]	1.8V
HEX0[4]	PIN_AT30	Seven Segment Digit 0[4]	1.8V
HEX0[5]	PIN_AU29	Seven Segment Digit 0[5]	1.8V
HEX0[6]	PIN_AV29	Seven Segment Digit 0[6]	1.8V
HEX0_DP	PIN_AU31	Seven Segment Digit 0_DP	1.8V
HEX1[0]	PIN_AT28	Seven Segment Digit 1[0]	1.8V
HEX1[1]	PIN_AT29	Seven Segment Digit 1[1]	1.8V
HEX1[2]	PIN_AR30	Seven Segment Digit 1[2]	1.8V
HEX1[3]	PIN_AM27	Seven Segment Digit 1[3]	1.8V
HEX1[4]	PIN_AL27	Seven Segment Digit 1[4]	1.8V
HEX1[5]	PIN_AK27	Seven Segment Digit 1[5]	1.8V
HEX1[6]	PIN_AM26	Seven Segment Digit 1[6]	1.8V
HEX1_DP	PIN_AR31	Seven Segment Digit 1_DP	1.8V

## 4.2 USB Type-C Port

The HAN Pilot Platform board features one USB Type-C connector. It is designed for high-speed data transmission with computers and image output applications. **Figure 4-5** shows the block diagram of the connection between USB Type-C port and FPGA.





**Figure 4-5 Block diagram of the connection between USB Type-C port and FPGA**

As shown in **Figure 4-5**, it connects to FPGA through several switch circuits and USB controllers, users can switch USB Type-C connector to a variety of applications as below:

- USB 3.0 Device to USB Host PC
- USB 2.0 OTG
- DisplayPort Source Application (Need DP Source IP)

The USB Type-C Port Controller will detect the type of USB device connected to the Type-C connector, automatically switches the "USB and DP" switch (U11), and connects the USB Type-C connector to the appropriate application in the HAN Pilot kit. If user connects a Display port monitor to the USB type-C connector of the Han Pilot kit, the "USB and DP" switch will be switched to the transceiver path of the FPGA by the USB type-C Port Controller, which is useful for the Display port output application. Similarly, when a USB 3.0 host device is connected to the USB Type-C connector, the "USB and DP" switch will be switched to the path of the cypress FX3.0 USB controller for USB 3.0 applications.

We will describe the circuits diagram and these functions in detail below.

## ■ Display Port

As shown in **Figure 4-6**, USB Type-C port can connect to FPGA transceiver. Users can implement a Display port source mode IP in the FPGA, the HAN Pilot Platform board will implement the features of display port source. Through the USB Type-C cable, users can connect HAN Pilot Platform board to the monitor which supports Display port interface. Then the image processed by FPGA can be displayed on the monitor. The display port provides data rate up to 5.4Gbps per lane and 4 lanes in total, it supports DisplayPort 1.2a Spec. **Table 4-5** list the pin assignment of DisplayPorts.

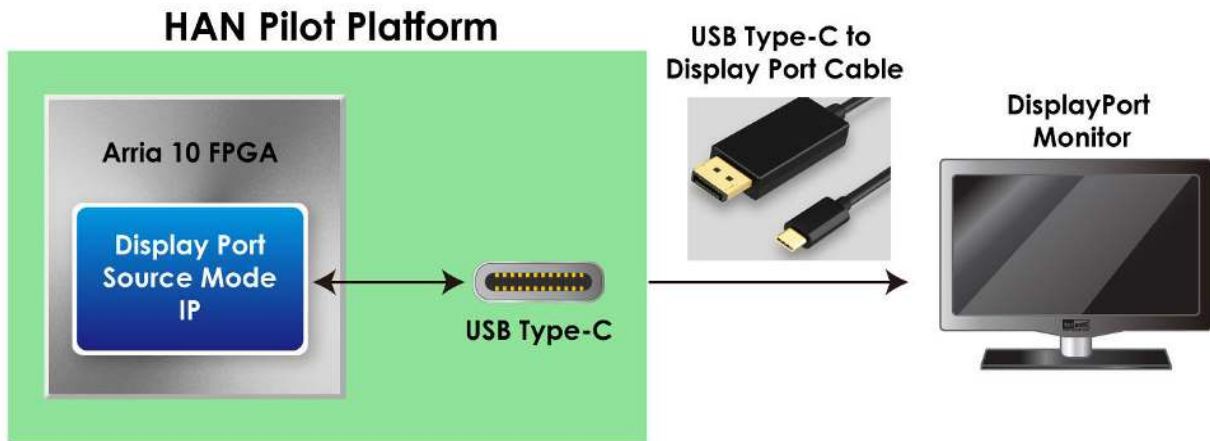


Figure 4-6 USB Type-C Application: DisplayPort TX Source

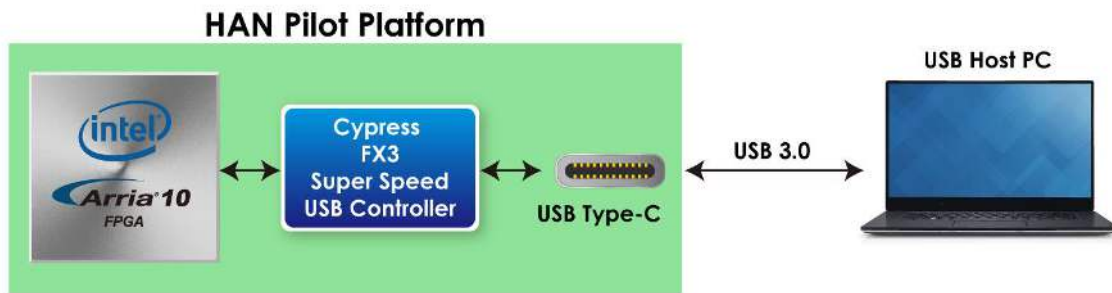
Table 4-5 DisplayPort Signal Names and Functions

Signal Name	FPGA Pin Number	Description	I/O Standard
DP_REFCLK_p	AM31	Display reference clock form PLL	LVDS
DP_TX_p[0]	AW37	TX Lane 1	HSSI Differential I/O
DP_TX_p[1]	AV39	TX Lane 2	HSSI Differential I/O
DP_TX_p[2]	AU37	TX Lane 3	HSSI Differential I/O
DP_TX_p[3]	AT39	TX Lane 4	HSSI Differential I/O
DP_AUX_p	AM22	Display port AUX port	DIFFERENTIAL 1.8-V SSTL CLASS I
DP_DX_SEL	AB27	Display Port channel TX or RX(Reserve) select. DP_DX_SEL = 0 : USB TypeC in Display TX mode . DP_DX_SEL = 1(Reserve): USB TypeC in Display RX mode	1.8 V
DP_AUX_SEL	AC28	AUX/DDC Selection Control Pin in Conjunction with Dx_SEL Pin	1.8 V
USBDP_SW_CNF0	AA27	Display port Switch Configure 0	1.8 V
USBDP_SW_CNF1	AB26	Display port Switch Configure 1	1.8 V
USBDP_SW_CNF2	AB25	Display port Switch	1.8 V

### ■ USB 3.0 Device

The HAN Pilot Platform board has one Cypress FX3 USB Controller (CYUSB3014). The USB controller is connected to FPGA through the programmable GPIF II interface, and connect to the external USB Type-C connector, it provides USB 3.0 Device application for HAN Pilot Platform board.

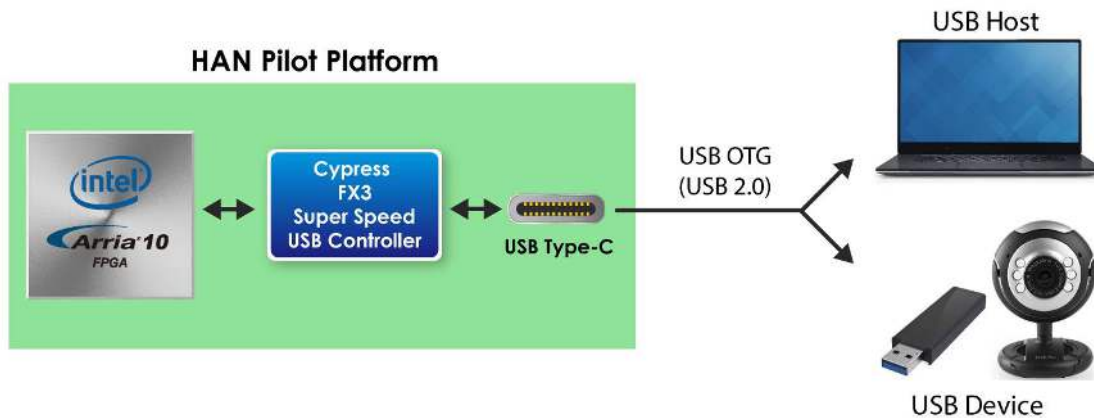
As shown in **Figure 4-7**, users can connect FX3 USB Controller to PC through USB Type-C cable, and transfer USB 3.0 data between FPGA and USB Host PC with transfer rate 320MByte/s (Using the demonstration provided by Cypress). **Table 4-6** list the pin assignment of FX3 USB 3.0 Controller.



**Figure 4-7 FX3 USB 3.0 Controller application**

### ■ USB 2.0 OTG

The Cypress FX3 USB controller also has a USB 2.0 OTG controller. It allows the HAN Pilot Platform board function as an OTG Host to MSC as well as HID-class devices, as shown in **Figure 4-8**.



**Figure 4-8 USB 2.0 OTG Controller application**

**Table 4-6 FX3 USB 3.0 Controller Signal Names and Functions**

Signal Name	FPGA Pin Number	Description	I/O Standard
USBFX3_DQ[0]	AU21	GPIF II Data Bus 0	1.8 V

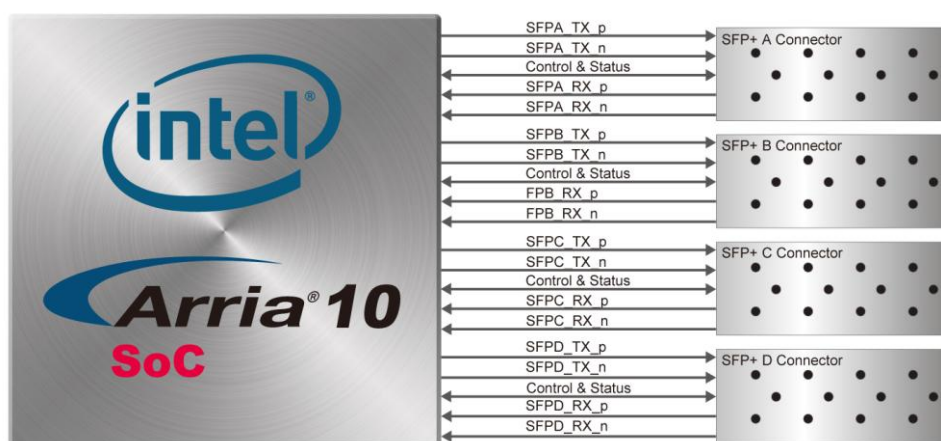
USBFX3_DQ[1]	AW23	GPIF II Data Bus 1	1.8 V
USBFX3_DQ[2]	AW24	GPIF II Data Bus 2	1.8 V
USBFX3_DQ[3]	AW25	GPIF II Data Bus 3	1.8 V
USBFX3_DQ[4]	AW26	GPIF II Data Bus 4	1.8 V
USBFX3_DQ[5]	AV24	GPIF II Data Bus 5	1.8 V
USBFX3_DQ[6]	AW28	GPIF II Data Bus 6	1.8 V
USBFX3_DQ[7]	AW30	GPIF II Data Bus 7	1.8 V
USBFX3_DQ[8]	AW29	GPIF II Data Bus 8	1.8 V
USBFX3_DQ[9]	AV27	GPIF II Data Bus 9	1.8 V
USBFX3_DQ[10]	AV28	GPIF II Data Bus 10	1.8 V
USBFX3_DQ[11]	AU26	GPIF II Data Bus 11	1.8 V
USBFX3_DQ[12]	AV23	GPIF II Data Bus 12	1.8 V
USBFX3_DQ[13]	AU25	GPIF II Data Bus 13	1.8 V
USBFX3_DQ[14]	AR25	GPIF II Data Bus 14	1.8 V
USBFX3_DQ[15]	AP24	GPIF II Data Bus 15	1.8 V
USBFX3_DQ[16]	AL23	GPIF II Data Bus 16	1.8 V
USBFX3_DQ[17]	AM24	GPIF II Data Bus 17	1.8 V
USBFX3_DQ[18]	AK25	GPIF II Data Bus 18	1.8 V
USBFX3_DQ[19]	AM25	GPIF II Data Bus 19	1.8 V
USBFX3_DQ[20]	AT24	GPIF II Data Bus 20	1.8 V
USBFX3_DQ[21]	AR26	GPIF II Data Bus 21	1.8 V
USBFX3_DQ[22]	AP26	GPIF II Data Bus 22	1.8 V
USBFX3_DQ[23]	AP25	GPIF II Data Bus 23	1.8 V
USBFX3_DQ[24]	AN24	GPIF II Data Bus 24	1.8 V
USBFX3_DQ[25]	AN26	GPIF II Data Bus 25	1.8 V
USBFX3_DQ[26]	AK23	GPIF II Data Bus 26	1.8 V
USBFX3_DQ[27]	AJ25	GPIF II Data Bus 27	1.8 V
USBFX3_DQ[28]	AJ23	GPIF II Data Bus 28	1.8 V
USBFX3_DQ[29]	AH23	GPIF II Data Bus 29	1.8 V
USBFX3_DQ[30]	AR20	GPIF II Data Bus 30	1.8 V
USBFX3_DQ[31]	AP20	GPIF II Data Bus 31	1.8 V
USBFX3_CTL0_SLCS_n	AV26	GPIF II Control Bus 0	1.8 V
USBFX3_CTL1_SLWR_n	AT22	GPIF II Control Bus 1	1.8 V



USBFX3_CTL2_SLOE_n	AT25	GPIF II Control Bus 2	1.8 V
USBFX3_CTL3_SLRD_n	AR27	GPIF II Control Bus 3	1.8 V
USBFX3_CTL4_FLAGA	AN22	GPIF II Control Bus 4	1.8 V
USBFX3_CTL5_FLAGB	AN23	GPIF II Control Bus 5	1.8 V
USBFX3_CTL6	AL24	GPIF II Control Bus 6	1.8 V
USBFX3_CTL7_PKTEND_n	AL25	GPIF II Control Bus 7	1.8 V
USBFX3_CTL8	AV21	GPIF II Control Bus 8	1.8 V
USBFX3_CTL9	AV22	GPIF II Control Bus 9	1.8 V
USBFX3_CTL10	AU24	GPIF II Control Bus 10	1.8 V
USBFX3_CTL11_A1	AU22	GPIF II Control Bus 11	1.8 V
USBFX3_CTL12_A0	AT23	GPIF II Control Bus 12	1.8 V
USBFX3_CTL15_INT_n	AW21	GPIF II Control Bus 15	1.8 V
USBFX3_RESET_n	AJ24	FX3 reset	1.8 V
USBFX3_PCLK	AT27	FX3 clock	1.8 V
USBFX3_UART_TX	AP23	USB to UART transmitter	1.8 V
USBFX3_UART_RX	AU27	USB to UART receiver	1.8 V
USBFX3_OTG_ID	AG26	OTG ID pin	1.8 V

### 4.3 SFP+ Connector

The development board has four independent 10G SFP+ connectors that use one transceiver channel each from the Arria 10 SoC FPGA device. These modules take in serial data from the Arria 10 SoC FPGA device and transform them to optical signals. The board includes cage assemblies for the SFP+ connectors. **Figure 4-9** shows the connections between the SFP+ and Arria 10 SoC FPGA.



**Figure 4-9 Connection between the SFP+ and Arria 10 SoC FPGA**

Table 4-7, Table 4-8, Table 4-9 and Table 4-10 list the four QSF+ connectors assignments and signal names relative to the Arria 10 SoC FPGA.

**Table 4-7 SFP+ A Pin Assignments, Signal Names and Functions**

Signal Name	FPGA Number	Pin	Description	I/O Standard
SFPA_TXDISABLE	PIN_AV6		Turns off and disables the transmitter output	1.2V
SFPA_TXFAULT	PIN_AP3		Transmitter fault	1.2V
SFPA_TX_p	PIN_AG37		Transmitter data	HSSI DIFFERENTIAL I/O
SFPA_RX_p	PIN_AD35		Receiver data	HSSI DIFFERENTIAL I/O
SFPA_LOS	PIN_AN6		Signal loss indicator	1.2V
SFPA_MOD0_PRSENT_n	PIN_AU4		Module present	1.2V
SFPA_RATESEL0	PIN_AM19		Rate select 0	1.8V
SFPA_RATESEL1	PIN_AN17		Rate select 1	1.8V
SFPA_MOD1_SCL	PIN_AW6		Transmitter data	1.2V
SFPA_MOD2_SDA	PIN_AW5		Receiver data	1.2V

**Table 4-8 SFP+ B Pin Assignments, Signal Names and Functions**

Signal Name	FPGA Number	Pin	Description	I/O Standard
SFPB_TXDISABLE	PIN_AU5		Turns off and disables the transmitter output	1.2V
SFPB_TXFAULT	PIN_AE10		Transmitter fault	1.2V

SFPB_TX_p	PIN_AF39	Transmitter data	HSSI DIFFERENTIAL I/O
SFPB_RX_p	PIN_AC37	Receiver data	HSSI DIFFERENTIAL I/O
SFPB_LOS	PIN_AN12	Signal loss indicator	1.2V
SFPB_MOD0_PRSENT_n	PIN_AT5	Module present	1.2V
SFPB_RATESEL0	PIN_AR18	Rate select 0	1.8V
SFPB_RATESEL1	PIN_AP18	Rate select 1	1.8V
SFPB_MOD1_SCL	PIN_AW4	Transmitter data	1.2V
SFPB_MOD2_SDA	PIN_AV4	Receiver data	1.2V

**Table 4-9 SFP+ C Pin Assignments, Signal Names and Functions**

Signal Name	FPGA Number	Pin	Description	I/O Standard
SFPC_TXDISABLE	PIN_AP30		Turns off and disables the transmitter output	1.2V
SFPC_TXFAULT	PIN_AP28		Transmitter fault	1.2V
SFPC_TX_p	PIN_AE37		Transmitter data	HSSI DIFFERENTIAL I/O
SFPC_RX_p	PIN_AC33		Receiver data	HSSI DIFFERENTIAL I/O
SFPC_LOS	PIN_AN28		Signal loss indicator	1.2V
SFPC_MOD0_PRSENT_n	PIN_B27		Module present	1.2V
SFPC_RATESEL0	PIN_AK18		Rate select 0	1.8V
SFPC_RATESEL1	PIN_AR17		Rate select 1	1.8V
SFPC_MOD1_SCL	PIN_AV3		Transmitter data	1.2V
SFPC_MOD2_SDA	PIN_AW3		Receiver data	1.2V

**Table 4-10 SFP+ D Pin Assignments, Signal Names and Functions**

Signal Name	FPGA Number	Pin	Description	I/O Standard
SFPD_TXDISABLE	PIN_AR28		Turns off and disables the transmitter output	1.2V
SFPD_TXFAULT	PIN_AP21		Transmitter fault	1.2V
SFPD_TX_p	PIN_AD39		Transmitter data	HSSI DIFFERENTIAL I/O

SFPD_RX_p	PIN_AB35	Receiver data	HSSI DIFFERENTIAL I/O
SFPD_LOS	PIN_D26	Signal loss indicator	1.2V
SFPD_MOD0_PRSENT_n	PIN_AL28	Module present	1.2V
SFPD_RATESEL0	PIN_AH18	Rate select 0	1.8V
SFPD_RATESEL1	PIN_AW19	Rate select 1	1.8V
SFPD_MOD1_SCL	PIN_AV2	Transmitter data	1.2V
SFPD_MOD2_SDA	PIN_AV1	Receiver data	1.2V
SFP_REFCLK_p	PIN_AD31	SFP Reference clock	LVDS

## 4.4 SATA

Four Serial ATA (SATA) ports are available on the FPGA development board which are computer bus standard with a primary function of transferring data between the motherboard and mass storage devices (such as hard drives, optical drives, and solid-state disks). Supporting a storage interface is just one of many different applications an FPGA can be used in storage appliances. The Arria 10 SoC device can bridge different protocols such as bridging simple bus I/Os like PCI Express (PCIe) to SATA or network interfaces such as Gigabit Ethernet (GbE) to SATA. The SATA interface supports SATA 3.0 standard with connection speed of 6 Gbps based on Arria 10 SoC device with integrated transceivers compliant to SATA electrical standards.

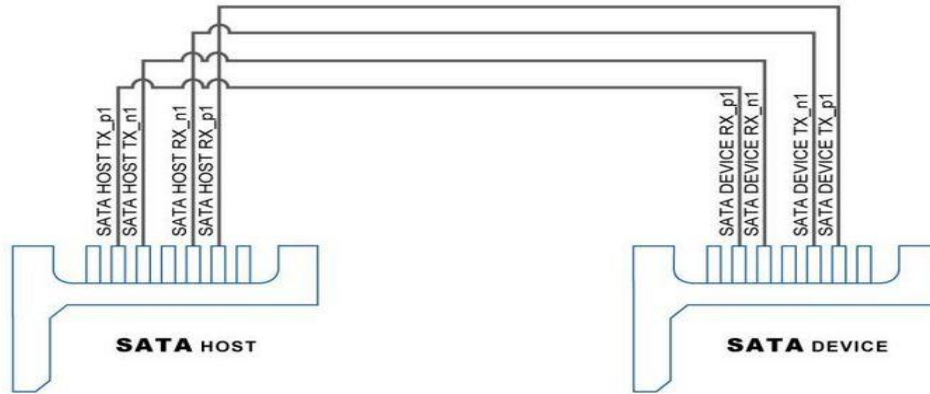
The four Serial ATA (SATA) ports include two available ports for device and two available ports for host capable of implementing SATA solution with a design that consists of both host and target (device side) functions. **Figure 4-10** depicts the host and device design examples.



**Figure 4-10 PC and storage device connection to the Arria 10 SoC FPGA**



The transmitter and receiver signals of the SATA ports are connected directly to the Arria 10 SoC transceiver channels to provide SATA IO connectivity to both host and target devices. To verify the functionality of the SATA host/device ports, a connection can be established between the two ports by using a SATA cable as **Figure 4-11** depicts the associated signals connected. **Table 4-11** lists the SATA pin assignments, signal names and functions.



**Figure 4-11 Pin connection between SATA connectors**

**Table 4-11 SATA Pin Assignments, Signal Names and Functions**

Signal Name	FPGA Pin Number	Description	I/O Standard
Device			
SATA_DEVICE_REFCLK_p	PIN_M31	SATA Device reference clock	LVDS
SATA_DEVICE_REFCLK_n	PIN_M30	SATA Device reference clock	LVDS
SATA_DEVICE_RX_n0	PIN_D34	Differential receive data input after DC blocking capacitor	HSSI DIFFERENTIAL I/O
SATA_DEVICE_RX_n1	PIN_B34	Differential receive data input after DC blocking capacitor	HSSI DIFFERENTIAL I/O
SATA_DEVICE_TX_n0	PIN_B38	Differential transmit data output before DC blocking capacitor	HSSI DIFFERENTIAL I/O
SATA_DEVICE_TX_n1	PIN_A36	Differential transmit data output before DC blocking capacitor	HSSI DIFFERENTIAL I/O
SATA_DEVICE_TX_p0	PIN_B39	Differential transmit data output before DC	HSSI DIFFERENTIAL

		blocking capacitor	I/O
SATA_DEVICE_TX_p1	PIN_A37	Differential transmit data output before DC blocking capacitor	HSSI DIFFERENTIAL I/O
SATA_DEVICE_RX_p0	PIN_D35	Differential receive data input after DC blocking capacitor	HSSI DIFFERENTIAL I/O
SATA_DEVICE_RX_p1	PIN_B35	Differential receive data input after DC blocking capacitor	HSSI DIFFERENTIAL I/O
Host			
SATA_HOST_REFCLK_p	PIN_AF31	SATA Host reference clock	LVDS
SATA_HOST_REFCLK_n	PIN_AF30	SATA Host reference clock	LVDS
SATA_HOST_TX_p0	PIN_AJ37	Differential transmit data output before DC blocking capacitor	HSSI DIFFERENTIAL I/O
SATA_HOST_TX_p1	PIN_AH39	Differential transmit data output before DC blocking capacitor	HSSI DIFFERENTIAL I/O
SATA_HOST_RX_p0	PIN_AE33	Differential receive data input after DC blocking capacitor	HSSI DIFFERENTIAL I/O
SATA_HOST_RX_p1	PIN_AF35	Differential receive data input after DC blocking capacitor	HSSI DIFFERENTIAL I/O
SATA_HOST_TX_n0	PIN_AJ36	Differential transmit data output before DC blocking capacitor	HSSI DIFFERENTIAL I/O
SATA_HOST_TX_n1	PIN_AH38	Differential transmit data output before DC blocking capacitor	HSSI DIFFERENTIAL I/O
SATA_HOST_RX_n0	PIN_AE32	Differential receive data input after DC blocking capacitor	HSSI DIFFERENTIAL I/O
SATA_HOST_RX_n1	PIN_AF34	Differential receive data input after DC blocking capacitor	HSSI DIFFERENTIAL I/O

## 4.5 PCIe

The HAN Pilot Platform board features one PCIe Express **downstream** interfaces (x4 lane) which are designed to interface with a PC motherboard x4 slot via PCIe cable and PCIe adapter card. Utilizing built-in transceivers on an Arria 10 SoC device, it is able to provide a fully integrated PCI Express-compliant solution for multi-lane (x4) applications. With the PCI Express hard IP block incorporated in the Arria 10 SoC device, it will allow users to implement simple and fast protocols, as well as saving logic resources for logic applications.

The PCI Express interface supports complete PCI Express Gen1 at 2.5Gbps/lane, Gen2 at 5.0Gbps/lane, and Gen3 at 8.0Gbps/lane protocol stack solution compliant to PCI Express base specification 3.0 that includes PHY-MAC, Data Link, and transaction layer circuitry embedded in PCI Express hard IP blocks.

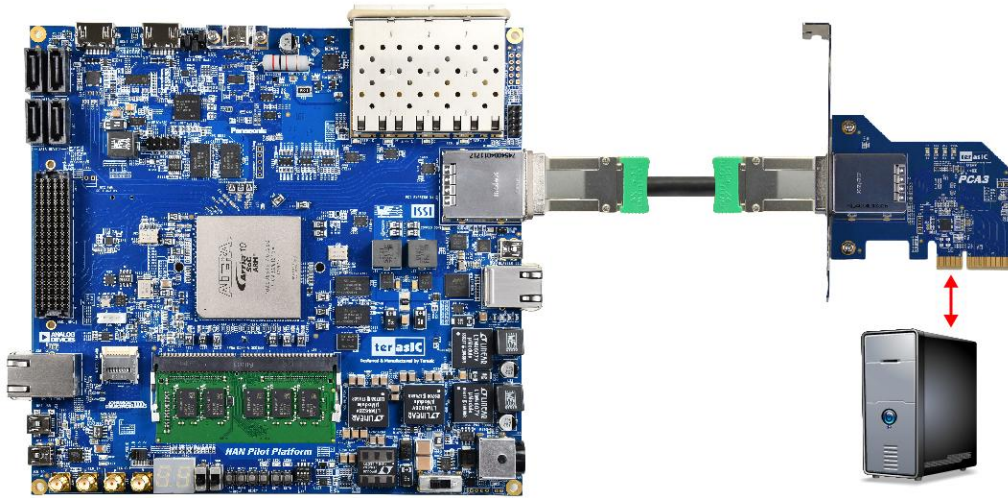
To use PCIe interface, two external associated devices will be needed to establish a link with PC. First, a PCIe half-height add-in host card with a PCIe x4 cable connector called PCA (PCIe Cabling Adapter Card and See **Figure 4-12**) will be used to plug into the PCIe slot on a mother board. Then, a PCIe x4 cable (See **Figure 4-13**) will be used to connect HAN Pilot Platform board and PCIe add-in card as shown in **Figure 4-14**, the longest length is up to 3 meters. These two associated devices are not included in HAN Pilot Platform kit. To purchase the PCA card as well as the external cable, please refer to Terasic website [pca.terasic.com](http://pca.terasic.com) and [PCIe.Cable.terasic.com](http://PCIe.Cable.terasic.com).



**Figure 4-12 PCIe Cabling Adaptor(PCA) card**



**Figure 4-13 PCIe External Cable**



**Figure 4-14 PCIe Link Setup between HAN Pilot Platform and PC**

**Table 4-12** summarizes the PCI Express pin assignments of the signal names relative to the Arria 10 FPGA.

**Table 4-12 PCI Express pin assignments of the signal names**

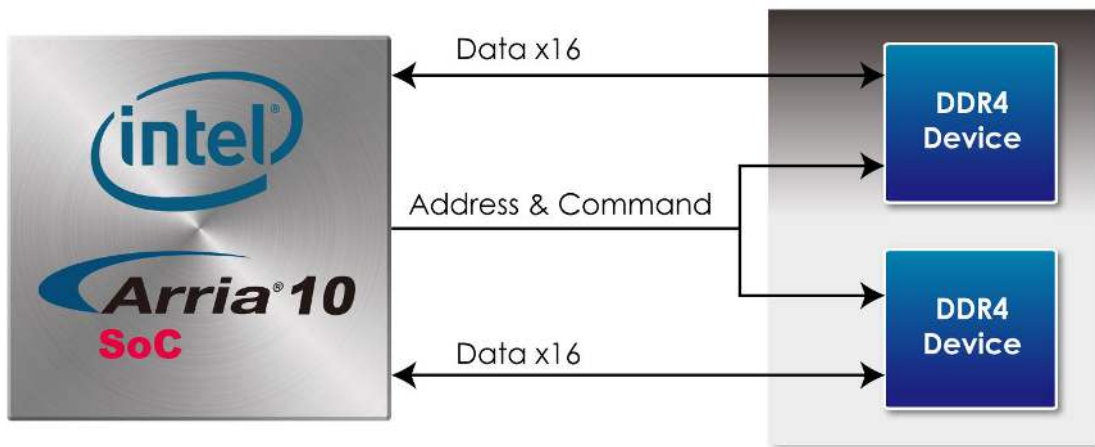
<b>Schematic Signal Name</b>	<b>Description</b>	<b>I/O Standard</b>	<b>Arria 10 Pin Number</b>
PCIE_REFCLK_p	PCIe reference clock	LVDS	PIN_AH31
PCIE_PREST_n	PCIe present, active low	1.8-V	PIN_AW20
PCIE_WAKE_n	PCIe wake	1.8-V	PIN_AL19
PCIE_TX_p[0]	PCIe Transmitter data p0	HSSI DIFFERENTIAL I/O	PIN_AR37
PCIE_RX_p[0]	PCIe Receiver data p0	HSSI DIFFERENTIAL I/O	PIN_AL33
PCIE_TX_p[1]	PCIe Transmitter data p1	HSSI DIFFERENTIAL I/O	PIN_AP39
PCIE_RX_p[1]	PCIe Receiver data p1	HSSI DIFFERENTIAL I/O	PIN_AM35
PCIE_TX_p[2]	PCIe Transmitter data p2	HSSI DIFFERENTIAL I/O	PIN_AN37
PCIE_RX_p[2]	PCIe Receiver data p2	HSSI DIFFERENTIAL I/O	PIN_AJ33



		I/O	
PCIE_TX_p[3]	PCIe Transmitter data p3	HSSI DIFFERENTIAL I/O	PIN_AM39
PCIE_RX_p[3]	PCIe Receiver data p3	HSSI DIFFERENTIAL I/O	PIN_AK35

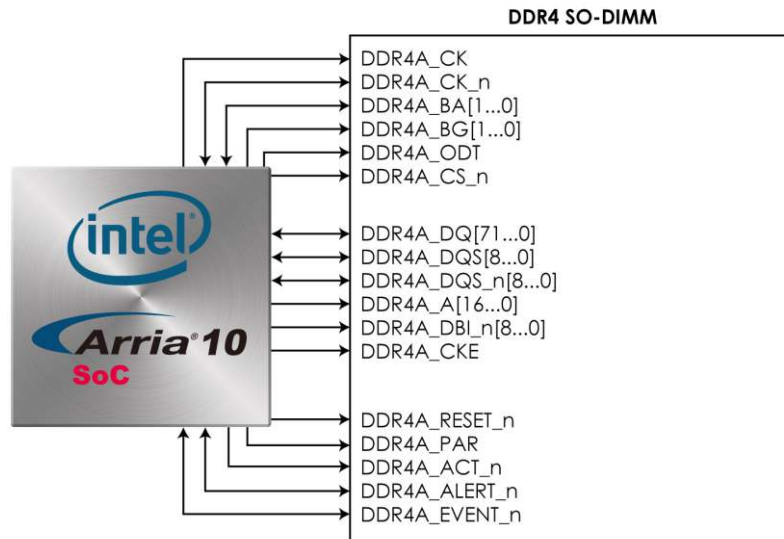
## 4.6 DDR4

The board supports 1GB on-board DDR4 SDRAM and one DDR4 SDRAM SO-DIMM socket on FPGA side. The on board DDR4 devices are running at 1067 MHz, for a total theoretical bandwidth of over 66Gbps. **Figure 4-15** shows the connections between the on board DDR4 and Arria 10 SoC FPGA. **Table 4-13** lists the pin assignments of the on board DDR4 and its description with I/O standard.



**Figure 4-15 The connection between DDR4 and Arria 10 SoC FPGA**

The DDR4 SDRAM SO-DIMM is wired to support a maximum capacity of 8GB with a 72-bit data bus. Using differential DQS signaling for the DDR4 SDRAM interfaces, it is capable of running at up to 1067MHz memory clock for a maximum theoretical bandwidth up to 132Gbps. **Figure 4-16** shows the connections between the DDR4 SDRAM SO-DIMM and Arria 10 SoC FPGA. The pin assignments for DDR4 SDRAM SO-DIMM are listed in **Table 4-14**.



**Figure 4-16 The connection between the DDR4 SDRAM SO-DIMM and Arria 10 SoC FPGA**

**Table 4-13 The pin assignments of DDR4 component and its description with I/O standard**

FPGA Pin Number	Signal Name	Description	I/O Standard
PIN_AU7	DDR4B_REFCLK_p	DDR4 A port Reference Clock	LVDS
PIN_AJ11	DDR4B_A[0]	Address [0]	SSTL-12
PIN_AH12	DDR4B_A[1]	Address [1]	SSTL-12
PIN_AP11	DDR4B_A[2]	Address [2]	SSTL-12
PIN_AN11	DDR4B_A[3]	Address [3]	SSTL-12
PIN_AM10	DDR4B_A[4]	Address [4]	SSTL-12
PIN_AM11	DDR4B_A[5]	Address [5]	SSTL-12
PIN_AP9	DDR4B_A[6]	Address [6]	SSTL-12
PIN_AN9	DDR4B_A[7]	Address [7]	SSTL-12
PIN_AR10	DDR4B_A[8]	Address [8]	SSTL-12
PIN_AP10	DDR4B_A[9]	Address [9]	SSTL-12
PIN_AM9	DDR4B_A[10]	Address [10]	SSTL-12
PIN_AL10	DDR4B_A[11]	Address [11]	SSTL-12
PIN_AV8	DDR4B_A[12]	Address [12]	SSTL-12
PIN_AT8	DDR4B_A[13]	Address [13]	SSTL-12
PIN_AT9	DDR4B_A[14]	Address [14]/WE_n	SSTL-12
PIN_AR7	DDR4B_A[15]	Address [15]/CAS_n	SSTL-12
PIN_AR8	DDR4B_A[16]	Address [16]/RAS_n	SSTL-12

PIN_AU6	DDR4B_BA[0]	Bank Select [0]	SSTL-12
PIN_AP8	DDR4B_BA[1]	Bank Select [1]	SSTL-12
PIN_AN8	DDR4B_BG[0]	Bank Group Select[0]	SSTL-12
PIN_AJ14	DDR4B_BG[1]	Bank Group Select[1]	SSTL-12
PIN_AL13	DDR4B_CK	Clock p0	DIFFERENTIAL 1.2-V SSTL
PIN_AK13	DDR4B_CK_n	Clock n0	DIFFERENTIAL 1.2-V SSTL
PIN_AK10	DDR4B_CKE	Clock Enable pin	SSTL-12
PIN_AE12	DDR4B_DQS[0]	Data Strobe p[0]	DIFFERENTIAL 1.2-V POD
PIN_AL7	DDR4B_DQS[1]	Data Strobe p[1]	DIFFERENTIAL 1.2-V POD
PIN_AR6	DDR4B_DQS[2]	Data Strobe p[2]	DIFFERENTIAL 1.2-V POD
PIN_AT2	DDR4B_DQS[3]	Data Strobe p[3]	DIFFERENTIAL 1.2-V POD
PIN_AF13	DDR4B_DQS_n[0]	Data Strobe n[0]	DIFFERENTIAL 1.2-V POD
PIN_AK8	DDR4B_DQS_n[1]	Data Strobe n[1]	DIFFERENTIAL 1.2-V POD
PIN_AP6	DDR4B_DQS_n[2]	Data Strobe n[2]	DIFFERENTIAL 1.2-V POD
PIN_AT3	DDR4B_DQS_n[3]	Data Strobe n[3]	DIFFERENTIAL 1.2-V POD
PIN_AF10	DDR4B_DBI_n[0]	Data Bus Inversion [0]	1.2-V POD
PIN_AL8	DDR4B_DBI_n[1]	Data Bus Inversion [1]	1.2-V POD
PIN_AN7	DDR4B_DBI_n[2]	Data Bus Inversion [2]	1.2-V POD
PIN_AN4	DDR4B_DBI_n[3]	Data Bus Inversion [3]	1.2-V POD
PIN_AF10	DDR4B_DBI_n[0]	Data Bus Inversion [0]	1.2-V POD
PIN_AJ9	DDR4B_DQ[0]	Data [0]	1.2-V POD
PIN_AG11	DDR4B_DQ[1]	Data [1]	1.2-V POD
PIN_AF9	DDR4B_DQ[2]	Data [2]	1.2-V POD
PIN_AG12	DDR4B_DQ[3]	Data [3]	1.2-V POD
PIN_AG9	DDR4B_DQ[4]	Data [4]	1.2-V POD

PIN_AF12	DDR4B_DQ[5]	Data [5]	1.2-V POD
PIN_AJ10	DDR4B_DQ[6]	Data [6]	1.2-V POD
PIN_AG10	DDR4B_DQ[7]	Data [7]	1.2-V POD
PIN_AL9	DDR4B_DQ[8]	Data [8]	1.2-V POD
PIN_AH9	DDR4B_DQ[9]	Data [9]	1.2-V POD
PIN_AK6	DDR4B_DQ[10]	Data [10]	1.2-V POD
PIN_AK7	DDR4B_DQ[11]	Data [11]	1.2-V POD
PIN_AH8	DDR4B_DQ[12]	Data [12]	1.2-V POD
PIN_AH7	DDR4B_DQ[13]	Data [13]	1.2-V POD
PIN_AJ8	DDR4B_DQ[14]	Data [14]	1.2-V POD
PIN_AE11	DDR4B_DQ[15]	Data [15]	1.2-V POD
PIN_AT4	DDR4B_DQ[16]	Data [16]	1.2-V POD
PIN_AM7	DDR4B_DQ[17]	Data [17]	1.2-V POD
PIN_AP5	DDR4B_DQ[18]	Data [18]	1.2-V POD
PIN_AL5	DDR4B_DQ[19]	Data [19]	1.2-V POD
PIN_AM5	DDR4B_DQ[20]	Data [20]	1.2-V POD
PIN_AM6	DDR4B_DQ[21]	Data [21]	1.2-V POD
PIN_AM4	DDR4B_DQ[22]	Data [22]	1.2-V POD
PIN_AR5	DDR4B_DQ[23]	Data [23]	1.2-V POD
PIN_AP1	DDR4B_DQ[24]	Data [24]	1.2-V POD
PIN_AR3	DDR4B_DQ[25]	Data [25]	1.2-V POD
PIN_AN3	DDR4B_DQ[26]	Data [26]	1.2-V POD
PIN_AR1	DDR4B_DQ[27]	Data [27]	1.2-V POD
PIN_AU2	DDR4B_DQ[28]	Data [28]	1.2-V POD
PIN_AP4	DDR4B_DQ[29]	Data [29]	1.2-V POD
PIN_AR2	DDR4B_DQ[30]	Data [30]	1.2-V POD
PIN_AU1	DDR4B_DQ[31]	Data [31]	1.2-V POD
PIN_AF10	DDR4B_DM[0]	DDR3 Data Mask[0]	1.2-V POD
PIN_AL8	DDR4B_DM[1]	DDR3 Data Mask[1]	1.2-V POD
PIN_AN7	DDR4B_DM[2]	DDR3 Data Mask[2]	1.2-V POD
PIN_AN4	DDR4B_DM[3]	DDR3 Data Mask[3]	1.2-V POD
PIN_AJ13	DDR4B_CS_n[0]	Chip Select	SSTL-12
PIN_AH14	DDR4B_RESET_n	Chip Reset	1.2 V



PIN_AL12	DDR4B_ODT	On Die Termination	SSTL-12
PIN_AM12	DDR4B_PAR	Command and Address Parity Input	SSTL-12
PIN_AH11	DDR4B_ALERT_n	Register ALERT_n output	SSTL-12
PIN_AH13	DDR4B_ACT_n	Activation Command Input	SSTL-12
PIN_AW8	DDR4B_RZQ	External reference ball for output drive calibration	1.2 V

**Table 4-14 The pin assignments for DDR4 SDRAM SO-DIMM**

FPGA Pin Number	Signal Name	Description	I/O Standard
PIN_AB12	DDR4A_REFCLK_p	DDR4 A port Reference Clock p	LVDS
PIN_AC1	DDR4A_A[0]	Address [0]	SSTL-12
PIN_AB1	DDR4A_A[1]	Address [1]	SSTL-12
PIN_AB4	DDR4A_A[2]	Address [2]	SSTL-12
PIN_AA5	DDR4A_A[3]	Address [3]	SSTL-12
PIN_AA3	DDR4A_A[4]	Address [4]	SSTL-12
PIN_AA4	DDR4A_A[5]	Address [5]	SSTL-12
PIN_Y2	DDR4A_A[6]	Address [6]	SSTL-12
PIN_AA2	DDR4A_A[7]	Address [7]	SSTL-12
PIN_AB5	DDR4A_A[8]	Address [8]	SSTL-12
PIN_AB6	DDR4A_A[9]	Address [9]	SSTL-12
PIN_W5	DDR4A_A[10]	Address [10]	SSTL-12
PIN_Y5	DDR4A_A[11]	Address [11]	SSTL-12
PIN_AA9	DDR4A_A[12]	Address [12]	SSTL-12
PIN_AB7	DDR4A_A[13]	Address [13]	SSTL-12
PIN_AA7	DDR4A_A[14]	Address [14]/WE_n	SSTL-12
PIN_AB10	DDR4A_A[15]	Address [15]/CAS_n	SSTL-12
PIN_AB11	DDR4A_A[16]	Address [16]/RAS_n	SSTL-12
PIN_Y7	DDR4A_BA[0]	Bank Select [0]	SSTL-12
PIN_AB9	DDR4A_BA[1]	Bank Select [1]	SSTL-12
PIN_AA10	DDR4A_BG[0]	Bank Group Select[0]	SSTL-12
PIN_AE2	DDR4A_BG[1]	Bank Group Select[1]	SSTL-12
PIN_AD3	DDR4A_CK	Clock p0	DIFFERENTIAL

			1.2-V SSTL
PIN_AD4	DDR4A_CK_n	Clock n0	DIFFERENTIAL 1.2-V SSTL
PIN_AC2	DDR4A_CKE	Clock Enable pin	SSTL-12
PIN_AE8	DDR4A_DQS[0]	Data Strobe p[0]	DIFFERENTIAL 1.2-V POD
PIN_AF7	DDR4A_DQS[1]	Data Strobe p[1]	DIFFERENTIAL 1.2-V POD
PIN_AN1	DDR4A_DQS[2]	Data Strobe p[2]	DIFFERENTIAL 1.2-V POD
PIN_AH2	DDR4A_DQS[3]	Data Strobe p[3]	DIFFERENTIAL 1.2-V POD
PIN_P1	DDR4A_DQS[4]	Data Strobe p[4]	DIFFERENTIAL 1.2-V POD
PIN_J3	DDR4A_DQS[5]	Data Strobe p[5]	DIFFERENTIAL 1.2-V POD
PIN_R5	DDR4A_DQS[6]	Data Strobe p[6]	DIFFERENTIAL 1.2-V POD
PIN_V9	DDR4A_DQS[7]	Data Strobe p[7]	DIFFERENTIAL 1.2-V POD
PIN_V2	DDR4A_DQS[8]	Data Strobe p[8]	DIFFERENTIAL 1.2-V POD
PIN_AD8	DDR4A_DQS_n[0]	Data Strobe n[0]	DIFFERENTIAL 1.2-V POD
PIN_AE7	DDR4A_DQS_n[1]	Data Strobe n[1]	DIFFERENTIAL 1.2-V POD
PIN_AN2	DDR4A_DQS_n[2]	Data Strobe n[2]	DIFFERENTIAL 1.2-V POD
PIN_AH3	DDR4A_DQS_n[3]	Data Strobe n[3]	DIFFERENTIAL 1.2-V POD
PIN_R1	DDR4A_DQS_n[4]	Data Strobe n[4]	DIFFERENTIAL 1.2-V POD
PIN_K3	DDR4A_DQS_n[5]	Data Strobe n[5]	DIFFERENTIAL 1.2-V POD
PIN_R6	DDR4A_DQS_n[6]	Data Strobe n[6]	DIFFERENTIAL 1.2-V POD
PIN_W9	DDR4A_DQS_n[7]	Data Strobe n[7]	DIFFERENTIAL

			1.2-V POD
PIN_V3	DDR4A_DQS_n[8]	Data Strobe n[8]	DIFFERENTIAL 1.2-V POD
PIN_AC11	DDR4A_DQ[0]	Data [0]	1.2-V POD
PIN_AD10	DDR4A_DQ[1]	Data [1]	1.2-V POD
PIN_AC9	DDR4A_DQ[2]	Data [2]	1.2-V POD
PIN_AG7	DDR4A_DQ[3]	Data [3]	1.2-V POD
PIN_AD13	DDR4A_DQ[4]	Data [4]	1.2-V POD
PIN_AD11	DDR4A_DQ[5]	Data [5]	1.2-V POD
PIN_AC8	DDR4A_DQ[6]	Data [6]	1.2-V POD
PIN_AF8	DDR4A_DQ[7]	Data [7]	1.2-V POD
PIN_AE6	DDR4A_DQ[8]	Data [8]	1.2-V POD
PIN_AJ6	DDR4A_DQ[9]	Data [9]	1.2-V POD
PIN_AG6	DDR4A_DQ[10]	Data [10]	1.2-V POD
PIN_AD6	DDR4A_DQ[11]	Data [11]	1.2-V POD
PIN_AG5	DDR4A_DQ[12]	Data [12]	1.2-V POD
PIN_AK5	DDR4A_DQ[13]	Data [13]	1.2-V POD
PIN_AC7	DDR4A_DQ[14]	Data [14]	1.2-V POD
PIN_AH6	DDR4A_DQ[15]	Data [15]	1.2-V POD
PIN_AK1	DDR4A_DQ[16]	Data [16]	1.2-V POD
PIN_AL4	DDR4A_DQ[17]	Data [17]	1.2-V POD
PIN_AJ4	DDR4A_DQ[18]	Data [18]	1.2-V POD
PIN_AM1	DDR4A_DQ[19]	Data [19]	1.2-V POD
PIN_AK3	DDR4A_DQ[20]	Data [20]	1.2-V POD
PIN_AL2	DDR4A_DQ[21]	Data [21]	1.2-V POD
PIN_AJ3	DDR4A_DQ[22]	Data [22]	1.2-V POD
PIN_AM2	DDR4A_DQ[23]	Data [23]	1.2-V POD
PIN_AF2	DDR4A_DQ[24]	Data [24]	1.2-V POD
PIN_AH1	DDR4A_DQ[25]	Data [25]	1.2-V POD
PIN_AG4	DDR4A_DQ[26]	Data [26]	1.2-V POD
PIN_AE5	DDR4A_DQ[27]	Data [27]	1.2-V POD
PIN_AF3	DDR4A_DQ[28]	Data [28]	1.2-V POD
PIN_AH4	DDR4A_DQ[29]	Data [29]	1.2-V POD

PIN_AG1	DDR4A_DQ[30]	Data [30]	1.2-V POD
PIN_AF4	DDR4A_DQ[31]	Data [31]	1.2-V POD
PIN_K1	DDR4A_DQ[32]	Data [32]	1.2-V POD
PIN_P4	DDR4A_DQ[33]	Data [33]	1.2-V POD
PIN_N2	DDR4A_DQ[34]	Data [34]	1.2-V POD
PIN_K2	DDR4A_DQ[35]	Data [35]	1.2-V POD
PIN_M2	DDR4A_DQ[36]	Data [36]	1.2-V POD
PIN_P3	DDR4A_DQ[37]	Data [37]	1.2-V POD
PIN_N1	DDR4A_DQ[38]	Data [38]	1.2-V POD
PIN_J1	DDR4A_DQ[39]	Data [39]	1.2-V POD
PIN_N3	DDR4A_DQ[40]	Data [40]	1.2-V POD
PIN_P5	DDR4A_DQ[41]	Data [41]	1.2-V POD
PIN_M5	DDR4A_DQ[42]	Data [42]	1.2-V POD
PIN_R2	DDR4A_DQ[43]	Data [43]	1.2-V POD
PIN_N4	DDR4A_DQ[44]	Data [44]	1.2-V POD
PIN_P6	DDR4A_DQ[45]	Data [45]	1.2-V POD
PIN_L4	DDR4A_DQ[46]	Data [46]	1.2-V POD
PIN_R3	DDR4A_DQ[47]	Data [47]	1.2-V POD
PIN_V6	DDR4A_DQ[48]	Data [48]	1.2-V POD
PIN_T7	DDR4A_DQ[49]	Data [49]	1.2-V POD
PIN_U5	DDR4A_DQ[50]	Data [50]	1.2-V POD
PIN_U7	DDR4A_DQ[51]	Data [51]	1.2-V POD
PIN_T4	DDR4A_DQ[52]	Data [52]	1.2-V POD
PIN_W6	DDR4A_DQ[53]	Data [53]	1.2-V POD
PIN_T3	DDR4A_DQ[54]	Data [54]	1.2-V POD
PIN_U6	DDR4A_DQ[55]	Data [55]	1.2-V POD
PIN_W8	DDR4A_DQ[56]	Data [56]	1.2-V POD
PIN_Y12	DDR4A_DQ[57]	Data [57]	1.2-V POD
PIN_Y11	DDR4A_DQ[58]	Data [58]	1.2-V POD
PIN_W10	DDR4A_DQ[59]	Data [59]	1.2-V POD
PIN_Y13	DDR4A_DQ[60]	Data [60]	1.2-V POD
PIN_Y8	DDR4A_DQ[61]	Data [61]	1.2-V POD
PIN_Y10	DDR4A_DQ[62]	Data [62]	1.2-V POD

PIN_W11	DDR4A_DQ[63]	Data [63]	1.2-V POD
PIN_V1	DDR4A_DQ[64]	Data [64]	1.2-V POD
PIN_Y1	DDR4A_DQ[65]	Data [65]	1.2-V POD
PIN_W3	DDR4A_DQ[66]	Data [66]	1.2-V POD
PIN_W1	DDR4A_DQ[67]	Data [67]	1.2-V POD
PIN_Y3	DDR4A_DQ[68]	Data [68]	1.2-V POD
PIN_W4	DDR4A_DQ[69]	Data [69]	1.2-V POD
PIN_U1	DDR4A_DQ[70]	Data [70]	1.2-V POD
PIN_U2	DDR4A_DQ[71]	Data [71]	1.2-V POD
PIN_AD9	DDR4A_DBI_n[0]	Data Bus Inversion [0]	1.2-V POD
PIN_AJ5	DDR4A_DBI_n[1]	Data Bus Inversion [1]	1.2-V POD
PIN_AK2	DDR4A_DBI_n[2]	Data Bus Inversion [2]	1.2-V POD
PIN_AG2	DDR4A_DBI_n[3]	Data Bus Inversion [3]	1.2-V POD
PIN_L2	DDR4A_DBI_n[4]	Data Bus Inversion [4]	1.2-V POD
PIN_L3	DDR4A_DBI_n[5]	Data Bus Inversion [5]	1.2-V POD
PIN_U4	DDR4A_DBI_n[6]	Data Bus Inversion [6]	1.2-V POD
PIN_V8	DDR4A_DBI_n[7]	Data Bus Inversion [7]	1.2-V POD
PIN_V4	DDR4A_DBI_n[8]	Data Bus Inversion [8]	1.2-V POD
PIN_AE1	DDR4A_CS_n	Chip Select	SSTL-12
PIN_AE3	DDR4A_RESET_n	Chip Reset	1.2 V
PIN_AC3	DDR4A_ODT	On Die Termination	SSTL-12
PIN_AC6	DDR4A_PAR	Command and Address Parity Input	SSTL-12
PIN_AC12	DDR4A_ALERT_n	Register ALERT_n output	SSTL-12
PIN_AD1	DDR4A_ACT_n	Activation Command Input	SSTL-12
PIN_T5	DDR4A_EVENT_n	Chip Temperature Event	1.2 V
PIN_AD5	DDR4A_AC_R[0]	Reserved QDRII+/RLDRAM3	for SSTL-12
PIN_Y6	DDR4A_AC_R[1]	Reserved QDRII+/RLDRAM3	for SSTL-12
PIN_AC4	DDR4A_C[0]	Reserved QDRII+/RLDRAM3	for SSTL-12
PIN_AB2	DDR4A_C[1]	Reserved QDRII+/RLDRAM3	for SSTL-12



PIN_AA8	DDR4A_RZQ	External reference ball for output drive calibration	1.2 V
---------	-----------	--	-------

The DDR4 SDRAM SO-DIMM socket can support many kinds of memory devices, such as standard DDR4 SO-DIMM with ECC up to 8GB at 1067MHz, Terasic QDRII+ module, as shown in **Figure 4-17**, **Figure 4-18**.



**Figure 4-17 Standard DDR4 SO-DIMM with ECC**



**Figure 4-18 Terasic QDRII+ module with DDR4 SO-DIMM interface**

## 4.7 HDMI Transmitter and Receiver

The HAN Pilot Platform board features HDMI transmitter and receiver.

For HDMI transmitter, as shown in **Figure 4-19**. The board features a Transition Minimized Differential Signal (TMDS) retimer IC (TI:SN75DP159). Users can implement Intel or third-party IP in FPGA; HDMI video or audio data is encoded to TMDS signal and output from FPGA transceiver. The signals transmit to the retimer IC and display on HDMI monitor through HDMI connector.

For HDMI Receiver, it features a Redriver IC (DIDOES: PI3HDX1204B1). It transmits the input TMDS signal into FPGA, and decoded to image video data by Intel or third-party IP, then will be processed next step. **Table 4-15** lists the HDMI Transmitter and Receiver pin assignments, signal names and functions.

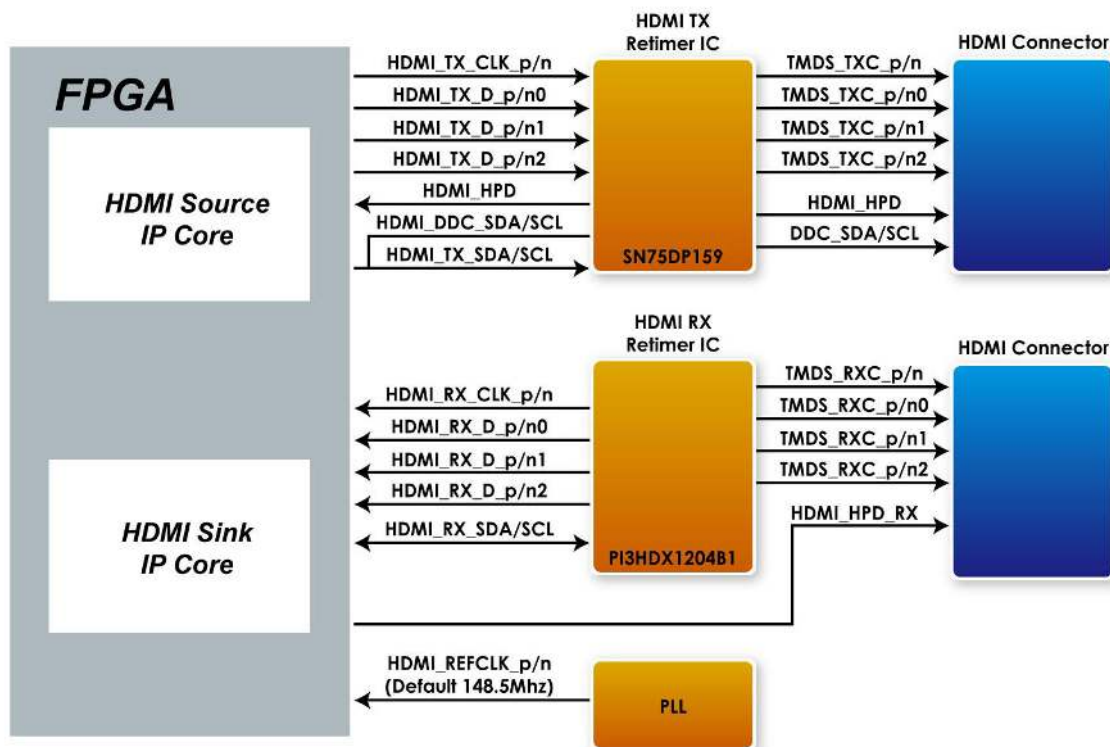


Figure 4-19 The HDMI transceiver interface of the HAN Pilot Platform

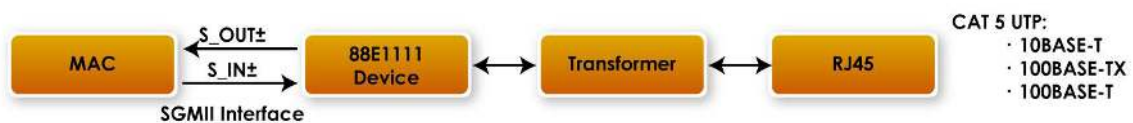
Table 4-15 HDMI TX and RX port Pin Assignments, Signal Names and Functions

Signal Name	FPGA Pin Number	Description	I/O Standard
HDMI_REFCLK_p	V31	HDMI reference clock from external PLL	LVDS
HDMI_TX_CLK_p	V39	TX TMDS clock channel	HSSI Differential I/O
HDMI_TX_D_p[0]	U37	TX TMDS data channel 0	HSSI Differential I/O
HDMI_TX_D_p[1]	T39	TX TMDS data channel 1	HSSI Differential I/O
HDMI_TX_D_p[2]	R37	TX TMDS data channel 2	HSSI Differential I/O
HDMI_TX_SCL	A25	I2C clock of the TX re-timer IC and DCC	1.8V
HDMI_TX_SDA	AB25	I2C data of the TX re-timer IC and DCC	1.8V
HDMI_HPD	AF28	TX Hot Plug Detect	1.8V
HDMI_TX_CEC	AK26	HDMI TX Consumer Electronics Control	1.8V
HDMI_RX_CLK_p	Y31	RX TMDS clock channel	HSSI Differential I/O
HDMI_RX_D_p[0]	Y35	RX TMDS data channel 0	HSSI Differential I/O

HDMI_RX_D_p[1]	W37	RX TMDS data channel 1	HSSI Differential I/O
HDMI_RX_D_p[2]	W33	RX TMDS data channel 2	HSSI Differential I/O
HDMI_RX_SCL	V7	I2C clock of the RX re-driver IC	1.2 V
HDMI_RX_SDA	T2	I2C clock of the RX re-driver IC	1.2 V
HDMI_HP_D_RX	AG27	RX Hot Plug Detect	1.8V
HDMI_RX_5V_N	B26	Detect if the TX terminal has 5V output	1.8V
HDMI_RX_CEC	AP29	HDMI RX Consumer Electronics Control	1.8V
DDCSCL_RX	AN27	HDMI DDC(Display Data Channel) I2C clock	1.8V
DDCSDA_RX	AJ26	HDMI DDC(Display Data Channel) I2C data	1.8V

## 4.8 Gigabit Ethernet

The development board supports one RJ45 10/100/1000 base-T Ethernet using Marvell 88E1111. SGMII AC coupling interface is used between PHY and FPGA transceiver. The device is an auto-negotiating Ethernet PHY with an SGMII interface to the FPGA. The Arria 10 SoC FPGA can communicate with the LVDS interfaces at up to 1.6 Gbps, which is faster than 1.25 Gbps for SGMII. The MAC function must be provided in the FPGA for typical networking applications. The Marvell 88E1111 PHY uses 2.5-V and 1.1-V power rails and requires a 25MHz reference clock driven from a dedicated oscillator. It interfaces to an RJ-45 with internal magnetics for driving copper lines with Ethernet traffic. **Figure 4-20** shows the SGMII interface between the FPGA and Marvell 88E1111 PHY. **Table 4-16** lists the Ethernet PHY interface pin assignments.



**Figure 4-20 SGMII Interface between FPGA and Marvell 88E1111 PHY**

**Table 4-16 Ethernet PHY Pin Assignments, Signal Names and Functions**

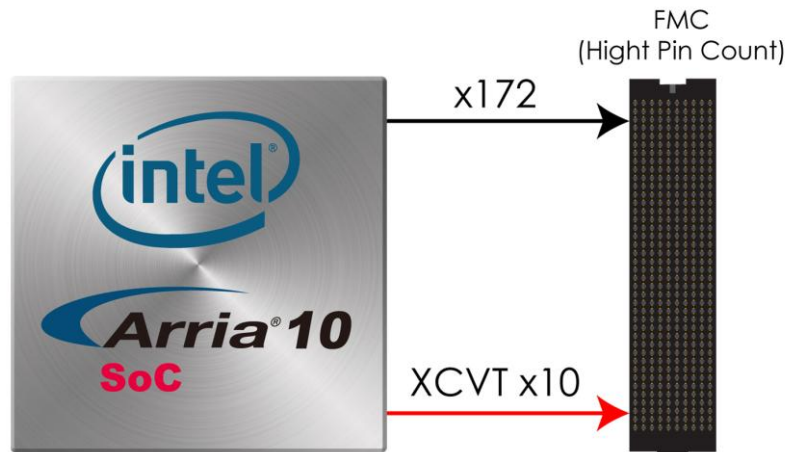
Signal Name	FPGA Pin Number	Description	I/O Standard
ETH_TX_p	PIN_AP19	SGMII TX data	LVDS
ETH_RX_p	PIN_AM20	SGMII RX data	LVDS
ETH_INT_n	PIN_AU19	Management bus interrupt	1.8V

ETH_MDC	PIN_AT19	Management bus control	1.8V
ETH_MDIO	PIN_AJ20	Management bus data	1.8V
ETH_RST_n	PIN_AK20	Device reset	1.8V

## 4.9 FMC Connector

The FPGA Mezzanine Card (FMC) interface provides a mechanism to extend the peripheral-set of an FPGA host board by means of add-on daughter cards, which can address today's high-speed signaling requirements as well as low-speed device interface support. The FMC interfaces support JTAG, clock outputs and inputs, high-speed serial I/O (transceivers), and single-ended or differential signaling.

There is one FMC connector on the HAN Pilot Platform board, it is a High Pin Count (HPC) size of connector, The HPC connector on HAN Pilot Platform board can provides 172 user-define, single-ended signals (include clock signals) and 10 serial transceiver pairs. **Figure 4-21** is the FMC connector on HAN Pilot Platform board.



**Figure 4-21** FMC connector on HAN Pilot Platform board

### ■ Clock Interface

**Table 4-17** shows the FPGA dedicated clock input pin placement on the FMC connector.

**Table 4-17** FMC clock interface distribution

<i>Signal Name</i>	<i>FMC Clock in/out pin name</i>	<i>FPGA Clock Input Pin Placement</i>	<i>FPGA Pin Assignment</i>
FMC_CLK_M2C_p0	CLK0_M2C_P	CLK_3F_1P	K5
FMC_CLK_M2C_n0	CLK0_M2C_N	CLK_3F_1N	L5
FMC_CLK_M2C_p1	CLK1_M2C_P	CLK_2A_1P	AW14
FMC_CLK_M2C_n1	CLK1_M2C_N	CLK_2A_1N	AW15
FMC_HA_p1	HA01_P_CC	CLK_3H_0P	M12
FMC_HA_n1	HA01_N_CC	CLK_3H_0N	N12
FMC_LA_p0	LA00_P_CC	CLK_3G_0P	A3

FMC_LA_p0	LA00_N_CC	CLK_3G_0N	A4
FMC_LA_p18	LA18_P_CC	CLK_3G_1P	K8
FMC_LA_n18	LA18_N_CC	CLK_3G_1N	L8

## ■ Power Supply

The HAN board provides 12V, 3.3V and VCCIO\_FMC power through FMC ports. **Table 4-18** indicates the maximum power consumption for the FMC connector. **Note that, according to VITA 57.1 the PRSNT\_M2C\_L pin(the HAN board FMC pin H2) should connect to GND to enable the FMC 12V power. The FMC 12V power is available when the FPGA board has detected PRSNT\_M2C\_L pin is pulled down.**

**CAUTION.** Before powering on the HAN board with a daughter card, please check to see if there is a short circuit between the power pins and FPGA I/O.

**Table 4-18 Power Supply of the FMC**

<i>Supplied Voltage</i>	<i>Max. Current Limit</i>
12V	1A
3.3V	2A
VCCIO_FMC	4A

## ■ Adjustable I/O Standards

The FPGA I/O standards of the FMC ports can be adjusted by configuring the header position. Each port can be individually adjusted to 1.2V, 1.5V or 1.8V via jumper JP2 on the HAN board. For detailed setting, please refer to Section 3.2.

## ■ JTAG Chain on FMC

The JTAG chain on the HAN board supports JTAG interface extension to the FMC connector so that the JTAG device on the user's FMC daughter card can be joined with JTAG chain on the HAN board. Users can enable this feature through the 2-pin header(J17) on the HAN board. In the board's default setting, the JTAG interface of the FMC connector is bypassed to keep the HAN board JTAG chain to maintain close loop. For detailed setting, please refer to Section 3.2.

## ■ FPGA Pin Assignments for FMC Connector

**Table 4-19** lists the FMC connector pin assignments, signal names and functions.

**Table 4-19 FMC Connector Pin Assignments, Signal Names and Functions**



Signal Name	FPGA Pin Number	Description	I/O Standard
FMC_CLK2_BIDIR_p	PIN_AW18	FMC data bus	FMC_VCCIO*(1)
FMC_CLK2_BIDIR_n	PIN_AV17	FMC data bus	FMC_VCCIO*(1)
FMC_CLK3_BIDIR_p	PIN_C1	FMC data bus	FMC_VCCIO*(1)
FMC_CLK3_BIDIR_n	PIN_D1	FMC data bus	FMC_VCCIO*(1)
FMC_CLK_M2C_p[0]	PIN_K5 *(2)	Clock from mezzanine module to carrier card positive 0	FMC_VCCIO*(1)
FMC_CLK_M2C_n[0]	PIN_L5*(2)	Clock from mezzanine module to carrier card negative 0	FMC_VCCIO*(1)
FMC_CLK_M2C_p[1]	PIN_AW14*(2)	Clock from mezzanine module to carrier card positive 1	FMC_VCCIO*(1)
FMC_CLK_M2C_n[1]	PIN_AW15*(2)	Clock from mezzanine module to carrier card negative 1	FMC_VCCIO*(1)
FMC_HA_p[0]	PIN_K12*(3)	FMC HA bank data p0	FMC_VCCIO*(1)
FMC_HA_p[1]	PIN_M12*(2)	FMC HA bank data p1	FMC_VCCIO*(1)
FMC_HA_p[2]	PIN_D10	FMC HA bank data p2	FMC_VCCIO*(1)
FMC_HA_p[3]	PIN_E12	FMC HA bank data p3	FMC_VCCIO*(1)
FMC_HA_p[4]	PIN_H13	FMC HA bank data p4	FMC_VCCIO*(1)
FMC_HA_p[5]	PIN_J11	FMC HA bank data p5	FMC_VCCIO*(1)
FMC_HA_p[6]	PIN_N13	FMC HA bank data p6	FMC_VCCIO*(1)
FMC_HA_p[7]	PIN_L13	FMC HA bank data p7	FMC_VCCIO*(1)
FMC_HA_p[8]	PIN_J14	FMC HA bank data p8	FMC_VCCIO*(1)
FMC_HA_p[9]	PIN_F13	FMC HA bank data p9	FMC_VCCIO*(1)
FMC_HA_p[10]	PIN_D13	FMC HA bank data p10	FMC_VCCIO*(1)
FMC_HA_p[11]	PIN_G14	FMC HA bank data p11	FMC_VCCIO*(1)
FMC_HA_p[12]	PIN_A10	FMC HA bank data p12	FMC_VCCIO*(1)
FMC_HA_p[13]	PIN_G12	FMC HA bank data p13	FMC_VCCIO*(1)
FMC_HA_p[14]	PIN_A12	FMC HA bank data p14	FMC_VCCIO*(1)
FMC_HA_p[15]	PIN_A7	FMC HA bank data p15	FMC_VCCIO*(1)
FMC_HA_p[16]	PIN_A9	FMC HA bank data p16	FMC_VCCIO*(1)
FMC_HA_p[17]	PIN_C12*(3)	FMC HA bank data p17	FMC_VCCIO*(1)

FMC_HA_p[18]	PIN_B11	FMC HA bank data p18	FMC_VCCIO*(1)
FMC_HA_p[19]	PIN_M7	FMC HA bank data p19	FMC_VCCIO*(1)
FMC_HA_p[20]	PIN_F10	FMC HA bank data p20	FMC_VCCIO*(1)
FMC_HA_p[21]	PIN_C9	FMC HA bank data p21	FMC_VCCIO*(1)
FMC_HA_p[22]	PIN_C8	FMC HA bank data p22	FMC_VCCIO*(1)
FMC_HA_p[23]	PIN_G11	FMC HA bank data p23	FMC_VCCIO*(1)
FMC_HA_n[0]	PIN_L12*(3)	FMC HA bank data n0	FMC_VCCIO*(1)
FMC_HA_n[1]	PIN_N12*(2)	FMC HA bank data n1	FMC_VCCIO*(1)
FMC_HA_n[2]	PIN_E10	FMC HA bank data n2	FMC_VCCIO*(1)
FMC_HA_n[3]	PIN_F12	FMC HA bank data n3	FMC_VCCIO*(1)
FMC_HA_n[4]	PIN_J13	FMC HA bank data n4	FMC_VCCIO*(1)
FMC_HA_n[5]	PIN_K11	FMC HA bank data n5	FMC_VCCIO*(1)
FMC_HA_n[6]	PIN_P13	FMC HA bank data n6	FMC_VCCIO*(1)
FMC_HA_n[7]	PIN_L14	FMC HA bank data n7	FMC_VCCIO*(1)
FMC_HA_n[8]	PIN_K13	FMC HA bank data n8	FMC_VCCIO*(1)
FMC_HA_n[9]	PIN_F14	FMC HA bank data n9	FMC_VCCIO*(1)
FMC_HA_n[10]	PIN_E13	FMC HA bank data n10	FMC_VCCIO*(1)
FMC_HA_n[11]	PIN_H14	FMC HA bank data n11	FMC_VCCIO*(1)
FMC_HA_n[12]	PIN_B10	FMC HA bank data n12	FMC_VCCIO*(1)
FMC_HA_n[13]	PIN_H12	FMC HA bank data n13	FMC_VCCIO*(1)
FMC_HA_n[14]	PIN_B12	FMC HA bank data n14	FMC_VCCIO*(1)
FMC_HA_n[15]	PIN_A8	FMC HA bank data n15	FMC_VCCIO*(1)
FMC_HA_n[16]	PIN_B9	FMC HA bank data n16	FMC_VCCIO*(1)
FMC_HA_n[17]	PIN_C13*(3)	FMC HA bank data n17	FMC_VCCIO*(1)
FMC_HA_n[18]	PIN_C11	FMC HA bank data n18	FMC_VCCIO*(1)
FMC_HA_n[19]	PIN_N7	FMC HA bank data n19	FMC_VCCIO*(1)
FMC_HA_n[20]	PIN_G10	FMC HA bank data n20	FMC_VCCIO*(1)
FMC_HA_n[21]	PIN_D9	FMC HA bank data n21	FMC_VCCIO*(1)
FMC_HA_n[22]	PIN_D8	FMC HA bank data n22	FMC_VCCIO*(1)
FMC_HA_n[23]	PIN_H11	FMC HA bank data n23	FMC_VCCIO*(1)
FMC_HB_p[0]	PIN_E1	FMC HB bank data p0	FMC_VCCIO*(1)
FMC_HB_p[1]	PIN_G4	FMC HB bank data p1	FMC_VCCIO*(1)
FMC_HB_p[2]	PIN_N8*(3)	FMC HB bank data p2	FMC_VCCIO*(1)

FMC_HB_p[3]	PIN_J4	FMC HB bank data p3	FMC_VCCIO*(1)
FMC_HB_p[4]	PIN_H2	FMC HB bank data p4	FMC_VCCIO*(1)
FMC_HB_p[5]	PIN_G5	FMC HB bank data p5	FMC_VCCIO*(1)
FMC_HB_p[6]	PIN_D3*(3)	FMC HB bank data p6	FMC_VCCIO*(1)
FMC_HB_p[7]	PIN_A2	FMC HB bank data p7	FMC_VCCIO*(1)
FMC_HB_p[8]	PIN_B1	FMC HB bank data p8	FMC_VCCIO*(1)
FMC_HB_p[9]	PIN_AT13	FMC HB bank data p9	FMC_VCCIO*(1)
FMC_HB_p[10]	PIN_AM17	FMC HB bank data p10	FMC_VCCIO*(1)
FMC_HB_p[11]	PIN_AJ16	FMC HB bank data p11	FMC_VCCIO*(1)
FMC_HB_p[12]	PIN_AW13	FMC HB bank data p12	FMC_VCCIO*(1)
FMC_HB_p[13]	PIN_AV14	FMC HB bank data p13	FMC_VCCIO*(1)
FMC_HB_p[14]	PIN_AP14	FMC HB bank data p14	FMC_VCCIO*(1)
FMC_HB_p[15]	PIN_AK16	FMC HB bank data p15	FMC_VCCIO*(1)
FMC_HB_p[16]	PIN_AU16*(3)	FMC HB bank data p16	FMC_VCCIO*(1)
FMC_HB_p[17]	PIN_AT17	FMC HB bank data p17	FMC_VCCIO*(1)
FMC_HB_p[18]	PIN_AM15	FMC HB bank data p18	FMC_VCCIO*(1)
FMC_HB_p[19]	PIN_AR15*(3)	FMC HB bank data p19	FMC_VCCIO*(1)
FMC_HB_p[20]	PIN_AP16	FMC HB bank data p20	FMC_VCCIO*(1)
FMC_HB_p[21]	PIN_AV18	FMC HB bank data p21	FMC_VCCIO*(1)
FMC_HB_n[0]	PIN_E2	FMC HB bank data n0	FMC_VCCIO*(1)
FMC_HB_n[1]	PIN_H4	FMC HB bank data n1	FMC_VCCIO*(1)
FMC_HB_n[2]	PIN_P8*(3)	FMC HB bank data n2	FMC_VCCIO*(1)
FMC_HB_n[3]	PIN_J5	FMC HB bank data n3	FMC_VCCIO*(1)
FMC_HB_n[4]	PIN_H3	FMC HB bank data n4	FMC_VCCIO*(1)
FMC_HB_n[5]	PIN_H6	FMC HB bank data n5	FMC_VCCIO*(1)
FMC_HB_n[6]	PIN_E3*(3)	FMC HB bank data n6	FMC_VCCIO*(1)
FMC_HB_n[7]	PIN_B2	FMC HB bank data n7	FMC_VCCIO*(1)
FMC_HB_n[8]	PIN_C2	FMC HB bank data n8	FMC_VCCIO*(1)
FMC_HB_n[9]	PIN_AT14	FMC HB bank data n9	FMC_VCCIO*(1)
FMC_HB_n[10]	PIN_AL17	FMC HB bank data n10	FMC_VCCIO*(1)
FMC_HB_n[11]	PIN_AH16	FMC HB bank data n11	FMC_VCCIO*(1)
FMC_HB_n[12]	PIN_AV13	FMC HB bank data n12	FMC_VCCIO*(1)
FMC_HB_n[13]	PIN_AU14	FMC HB bank data n13	FMC_VCCIO*(1)

FMC_HB_n[14]	PIN_AP15	FMC HB bank data n14	FMC_VCCIO*(1)
FMC_HB_n[15]	PIN_AK17	FMC HB bank data n15	FMC_VCCIO*(1)
FMC_HB_n[16]	PIN_AU17*(3)	FMC HB bank data n16	FMC_VCCIO*(1)
FMC_HB_n[17]	PIN_AT18	FMC HB bank data n17	FMC_VCCIO*(1)
FMC_HB_n[18]	PIN_AM16	FMC HB bank data n18	FMC_VCCIO*(1)
FMC_HB_n[19]	PIN_AR16*(3)	FMC HB bank data n19	FMC_VCCIO*(1)
FMC_HB_n[20]	PIN_AN16	FMC HB bank data n20	FMC_VCCIO*(1)
FMC_HB_n[21]	PIN_AV19	FMC HB bank data n21	FMC_VCCIO*(1)
FMC_LA_p[0]	PIN_A3*(2)	FMC LA bank data p0	FMC_VCCIO*(1)
FMC_LA_p[1]	PIN_B4*(3)	FMC LA bank data p1	FMC_VCCIO*(1)
FMC_LA_p[2]	PIN_T9	FMC LA bank data p2	FMC_VCCIO*(1)
FMC_LA_p[3]	PIN_M10	FMC LA bank data p3	FMC_VCCIO*(1)
FMC_LA_p[4]	PIN_U9	FMC LA bank data p4	FMC_VCCIO*(1)
FMC_LA_p[5]	PIN_J10	FMC LA bank data p5	FMC_VCCIO*(1)
FMC_LA_p[6]	PIN_H8	FMC LA bank data p6	FMC_VCCIO*(1)
FMC_LA_p[7]	PIN_L9	FMC LA bank data p7	FMC_VCCIO*(1)
FMC_LA_p[8]	PIN_M9	FMC LA bank data p8	FMC_VCCIO*(1)
FMC_LA_p[9]	PIN_G6	FMC LA bank data p9	FMC_VCCIO*(1)
FMC_LA_p[10]	PIN_E8	FMC LA bank data p10	FMC_VCCIO*(1)
FMC_LA_p[11]	PIN_B6	FMC LA bank data p11	FMC_VCCIO*(1)
FMC_LA_p[12]	PIN_A5	FMC LA bank data p12	FMC_VCCIO*(1)
FMC_LA_p[13]	PIN_D5	FMC LA bank data p13	FMC_VCCIO*(1)
FMC_LA_p[14]	PIN_B7	FMC LA bank data p14	FMC_VCCIO*(1)
FMC_LA_p[15]	PIN_E6	FMC LA bank data p15	FMC_VCCIO*(1)
FMC_LA_p[16]	PIN_E5	FMC LA bank data p16	FMC_VCCIO*(1)
FMC_LA_p[17]	PIN_F9*(3)	FMC LA bank data p17	FMC_VCCIO*(1)
FMC_LA_p[18]	PIN_K8*(2)	FMC LA bank data p18	FMC_VCCIO*(1)
FMC_LA_p[19]	PIN_R8	FMC LA bank data p19	FMC_VCCIO*(1)
FMC_LA_p[20]	PIN_F7	FMC LA bank data p20	FMC_VCCIO*(1)
FMC_LA_p[21]	PIN_C4	FMC LA bank data p21	FMC_VCCIO*(1)
FMC_LA_p[22]	PIN_U11	FMC LA bank data p22	FMC_VCCIO*(1)
FMC_LA_p[23]	PIN_V11	FMC LA bank data p23	FMC_VCCIO*(1)
FMC_LA_p[24]	PIN_R11	FMC LA bank data p24	FMC_VCCIO*(1)

FMC_LA_p[25]	PIN_F2	FMC LA bank data p25	FMC_VCCIO*(1)
FMC_LA_p[26]	PIN_R7	FMC LA bank data p26	FMC_VCCIO*(1)
FMC_LA_p[27]	PIN_T12	FMC LA bank data p27	FMC_VCCIO*(1)
FMC_LA_p[28]	PIN_J6	FMC LA bank data p28	FMC_VCCIO*(1)
FMC_LA_p[29]	PIN_G1	FMC LA bank data p29	FMC_VCCIO*(1)
FMC_LA_p[30]	PIN_K7	FMC LA bank data p30	FMC_VCCIO*(1)
FMC_LA_p[31]	PIN_P10	FMC LA bank data p31	FMC_VCCIO*(1)
FMC_LA_p[32]	PIN_M6	FMC LA bank data p32	FMC_VCCIO*(1)
FMC_LA_p[33]	PIN_N11	FMC LA bank data p33	FMC_VCCIO*(1)
FMC_LA_n[0]	PIN_A4*(2)	FMC LA bank data n0	FMC_VCCIO*(1)
FMC_LA_n[1]	PIN_C3*(3)	FMC LA bank data n1	FMC_VCCIO*(1)
FMC_LA_n[2]	PIN_T10	FMC LA bank data n2	FMC_VCCIO*(1)
FMC_LA_n[3]	PIN_M11	FMC LA bank data n3	FMC_VCCIO*(1)
FMC_LA_n[4]	PIN_U10	FMC LA bank data n4	FMC_VCCIO*(1)
FMC_LA_n[5]	PIN_K10	FMC LA bank data n5	FMC_VCCIO*(1)
FMC_LA_n[6]	PIN_J8	FMC LA bank data n6	FMC_VCCIO*(1)
FMC_LA_n[7]	PIN_L10	FMC LA bank data n7	FMC_VCCIO*(1)
FMC_LA_n[8]	PIN_N9	FMC LA bank data n8	FMC_VCCIO*(1)
FMC_LA_n[9]	PIN_H7	FMC LA bank data n9	FMC_VCCIO*(1)
FMC_LA_n[10]	PIN_F8	FMC LA bank data n10	FMC_VCCIO*(1)
FMC_LA_n[11]	PIN_C6	FMC LA bank data n11	FMC_VCCIO*(1)
FMC_LA_n[12]	PIN_B5	FMC LA bank data n12	FMC_VCCIO*(1)
FMC_LA_n[13]	PIN_D6	FMC LA bank data n13	FMC_VCCIO*(1)
FMC_LA_n[14]	PIN_C7	FMC LA bank data n14	FMC_VCCIO*(1)
FMC_LA_n[15]	PIN_E7	FMC LA bank data n15	FMC_VCCIO*(1)
FMC_LA_n[16]	PIN_F5	FMC LA bank data n16	FMC_VCCIO*(1)
FMC_LA_n[17]	PIN_G9*(3)	FMC LA bank data n17	FMC_VCCIO*(1)
FMC_LA_n[18]	PIN_L8*(2)	FMC LA bank data n18	FMC_VCCIO*(1)
FMC_LA_n[19]	PIN_P9	FMC LA bank data n19	FMC_VCCIO*(1)
FMC_LA_n[20]	PIN_G7	FMC LA bank data n20	FMC_VCCIO*(1)
FMC_LA_n[21]	PIN_D4	FMC LA bank data n21	FMC_VCCIO*(1)
FMC_LA_n[22]	PIN_U12	FMC LA bank data n22	FMC_VCCIO*(1)
FMC_LA_n[23]	PIN_V12	FMC LA bank data n23	FMC_VCCIO*(1)



FMC_LA_n[24]	PIN_R12	FMC LA bank data n24	FMC_VCCIO*(1)
FMC_LA_n[25]	PIN_G2	FMC LA bank data n25	FMC_VCCIO*(1)
FMC_LA_n[26]	PIN_T8	FMC LA bank data n26	FMC_VCCIO*(1)
FMC_LA_n[27]	PIN_T13	FMC LA bank data n27	FMC_VCCIO*(1)
FMC_LA_n[28]	PIN_K6	FMC LA bank data n28	FMC_VCCIO*(1)
FMC_LA_n[29]	PIN_H1	FMC LA bank data n29	FMC_VCCIO*(1)
FMC_LA_n[30]	PIN_L7	FMC LA bank data n30	FMC_VCCIO*(1)
FMC_LA_n[31]	PIN_R10	FMC LA bank data n31	FMC_VCCIO*(1)
FMC_LA_n[32]	PIN_N6	FMC LA bank data n32	FMC_VCCIO*(1)
FMC_LA_n[33]	PIN_P11	FMC LA bank data n33	FMC_VCCIO*(1)
FMC_GBTCLK_M2C_p[0]	PIN_P31	LVDS input from the installed FMC card to dedicated reference clock inputs	LVDS
FMC_GBTCLK_M2C_p[1]	PIN_K31	LVDS input from the installed FMC card to dedicated reference clock inputs	LVDS
FMC_REFCLK_p	PIN_T31	FPGA transceiver Reference Clock (From on board PLL)	LVDS
FMC_DP_C2M_p[0]	PIN_M39	Transmit pair p0 of the FPGA transceiver	HSSI DIFFERENTIAL I/O
FMC_DP_C2M_p[1]	PIN_L37	Transmit pair p1 of the FPGA transceiver	HSSI DIFFERENTIAL I/O
FMC_DP_C2M_p[2]	PIN_K39	Transmit pair p2 of the FPGA transceiver	HSSI DIFFERENTIAL I/O
FMC_DP_C2M_p[3]	PIN_J37	Transmit pair p3 of the FPGA transceiver	HSSI DIFFERENTIAL I/O
FMC_DP_C2M_p[4]	PIN_H39	Transmit pair p4 of the FPGA transceiver	HSSI DIFFERENTIAL I/O
FMC_DP_C2M_p[5]	PIN_G37	Transmit pair p5 of the FPGA transceiver	HSSI DIFFERENTIAL

			I/O
FMC_DP_C2M_p[6]	PIN_F39	Transmit pair p6 of the FPGA transceiver	HSSI DIFFERENTIAL I/O
FMC_DP_C2M_p[7]	PIN_E37	Transmit pair p7 of the FPGA transceiver	HSSI DIFFERENTIAL I/O
FMC_DP_C2M_p[8]	PIN_D39	Transmit pair p8 of the FPGA transceiver	HSSI DIFFERENTIAL I/O
FMC_DP_C2M_p[9]	PIN_C37	Transmit pair p9 of the FPGA transceiver	HSSI DIFFERENTIAL I/O
FMC_DP_M2C_p[0]	PIN_P35	Receiver pair p0 of the FPGA transceiver	HSSI DIFFERENTIAL I/O
FMC_DP_M2C_p[1]	PIN_R33	Receiver pair p1 of the FPGA transceiver	HSSI DIFFERENTIAL I/O
FMC_DP_M2C_p[2]	PIN_M35	Receiver pair p2 of the FPGA transceiver	HSSI DIFFERENTIAL I/O
FMC_DP_M2C_p[3]	PIN_N33	Receiver pair p3 of the FPGA transceiver	HSSI DIFFERENTIAL I/O
FMC_DP_M2C_p[4]	PIN_K35	Receiver pair p4 of the FPGA transceiver	HSSI DIFFERENTIAL I/O
FMC_DP_M2C_p[5]	PIN_L33	Receiver pair p5 of the FPGA transceiver	HSSI DIFFERENTIAL I/O
FMC_DP_M2C_p[6]	PIN_H35	Receiver pair p6 of the FPGA transceiver	HSSI DIFFERENTIAL I/O
FMC_DP_M2C_p[7]	PIN_J33	Receiver pair p7 of the FPGA transceiver	HSSI DIFFERENTIAL I/O
FMC_DP_M2C_p[8]	PIN_F35	Receiver pair p8 of the FPGA transceiver	HSSI DIFFERENTIAL I/O

FMC_DP_M2C_p[9]	PIN_G33	Receiver pair p9 of the FPGA transceiver	HSSI DIFFERENTIAL I/O
FMC_GA[0]	PIN_E11	FMC geographical address 0	3.3 V*(4)
FMC_GA[1]	PIN_AL18	FMC geographical address 1	3.3 V*(4)
FMC_SCL	PIN_J9	Management serial clock line	3.3 V*(4)
FMC_SDA	PIN_F4	Management serial data line	3.3V*(4)
FMC_RZQ	PIN_H9	Reserved for Memory FMC card	FMC_VCCIO*(1)

- \*(1): The FMC\_VCCIO value depends on the setting of JP2, which can adjust the FMC\_VCCIO to **1.2V, 1.5V or 1.8V**. Please refer to section 3.2 : “FMC\_VCCIO Select Header” for details.
- \*(2): FPGA dedicated clock input pin.
- \*(3): FPGA PLL clock output pin.
- \*(4) There are level shift ICs that convert FMC\_VCCIO to 3.3V between the FPGA pins and the FMC pins.

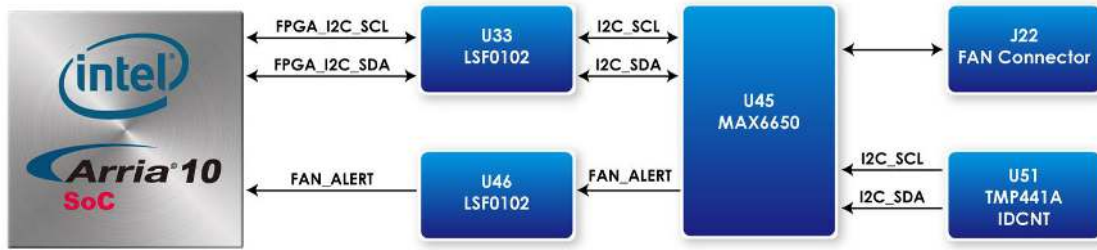
## 4.10 Temperature Sensor, Fan Control and Power Monitor

The FPGA board is equipped with a temperature sensor, TMP441AIDCNT, which provides temperature sensing. This function is accomplished by connecting the temperature sensor to the internal temperature sensing diode of the Arria 10 SoC device. The temperature status and alarm threshold registers of the temperature sensor can be programmed by a two-wire SMBus, which is connected to the Arria 10 SoC FPGA. In addition, the 7-bit POR slave address for this sensor is set to '0011100b'.

A 3-pin +12V fan located on J22 of the FPGA board is intended to reduce the temperature of the FPGA. The board is equipped with a Fan-Speed regulator and monitor MAX6650 with an I2C/SMBus interfaces, Users regulate and monitor the speed of fan depending on the measured system temperature.

The HAN Pilot Platform has implemented a power monitor chip to monitor the board input power voltage and current. **Figure 4-22** shows the connection between the power monitor chip and the Arria 10 SoC FPGA. The power monitor chip monitors both shunt voltage drops and board input power voltage allows user to monitor the total board power consumption. Programmable calibration value, conversion times, and averaging, combined with an internal multiplier, enable direct readouts

of current in amperes and power in watts. Note that, the temperature sensor, fan control and power monitor share the same I2C/SMBUS. **Table 4-20** lists the pin assignments, signal names and functions



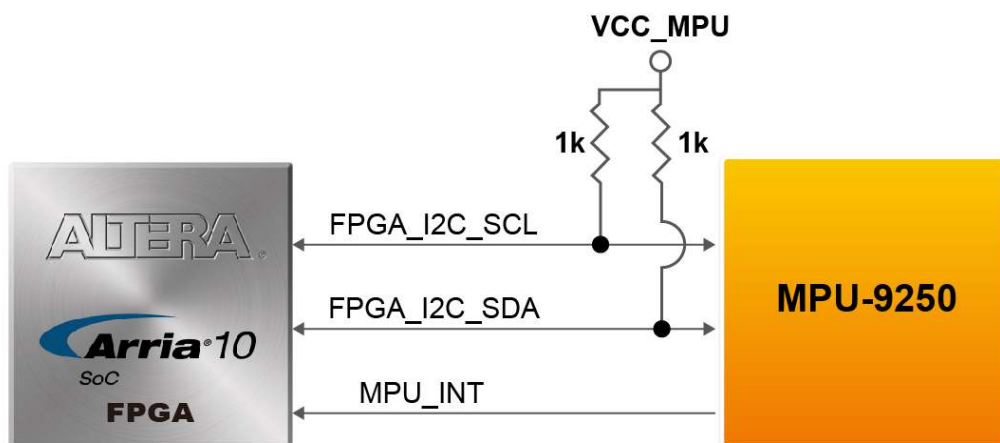
**Figure 4-22 Connections between the temperature sensor/fan control/power monitor and the Arria 10 SoC FPGA**

**Table 4-20 Temperature Sensor and Fan Speed Control Pin Assignments, Schematic Signal Names and Functions**

Schematic Signal Name	Description	I/O Standard	Arria 10 SoC Pin Number
TEMPDIODEp	Positive pin of temperature diode in Arria 10	--	--
TEMPDIODEn	Negative pin of temperature diode in Arria 10	--	--
FPGA_I2C_SCL	SMBus clock	1.8V	M1
FPGA_I2C_SDA	SMBus data	1.8V	M4
FAN_ALERT	Active-low ALERT input	1.8V	E25

## 4.11 Gyroscope, Accelerometer and Magnetometer

The HAN Pilot Platform board is equipped with a Motion-Tracking device named MPU-9250. The MPU-9250 is a 9-axis Motion-Tracking device that combines a 3-axis gyroscope, 3-axis accelerometer and 3-axis magnetometer. Detail features of these sensors are listed below.



**Figure 4-23 Connections between the MPU-9250 and the Arria 10 SoC FPGA**

## ■ Gyroscope

The MPU-9250 consists of three independent vibratory MEMS rate gyroscopes, which detect rotation about the X-, Y-, and Z- Axes. When the gyros are rotated about any of the sense axes, the Coriolis Effect causes a vibration that is detected by a capacitive pickoff. The resulting signal is amplified, demodulated, and filtered to produce a voltage that is proportional to the angular rate. This voltage is digitized using individual on-chip 16-bit Analog-to-Digital Converters (ADCs) to sample each axis. The full-scale range of the gyro sensors may be digitally programmed to  $\pm 250$ ,  $\pm 500$ ,  $\pm 1000$ , or  $\pm 2000$  degrees per second (dps). The ADC sample rate is programmable from 8,000 samples per second, down to 3.9 samples per second, and user-selectable low-pass filters enable a wide range of cut-off frequencies.

## ■ Accelerometer

The MPU-9250's 3-Axis accelerometer uses separate proof masses for each axis. Acceleration along a particular axis induces displacement on the corresponding proof mass, and capacitive sensors detect the displacement differentially. The MPU-9250's architecture reduces the accelerometers' susceptibility to fabrication variations as well as to thermal drift. When the device is placed on a flat surface, it will measure 0g on the X- and Y-axes and +1g on the Z-axis. The accelerometers' scale factor is calibrated at the factory and is nominally independent of supply voltage. Each sensor has a dedicated sigma-delta ADC for providing digital outputs. The full scale range of the digital output can be adjusted to  $\pm 2g$ ,  $\pm 4g$ ,  $\pm 8g$ , or  $\pm 16g$ .

## ■ Magnetometer

The 3-axis magnetometer uses highly sensitive Hall sensor technology. The magnetometer portion of the IC incorporates magnetic sensors for detecting terrestrial magnetism in the X-, Y-, and Z- Axes, a sensor driving circuit, a signal amplifier chain, and an arithmetic circuit for processing the signal from each sensor. Each ADC has a 16-bit resolution and a full scale range of  $\pm 4800 \mu T$ .

Communication with all registers of the device is performed using either I2C at 400kHz on the HAN Pilot platform. or SPI at 1MHz. For applications requiring faster communications, the sensor and interrupt registers may be read using SPI at 20MHz. The I2C address is 7'b1101001. For more detailed information of better using this chip, please refer to its datasheet which is available on



manufacturer’s website or under the /datasheet folder of the system CD. **Table 4-21** gives the pin assignment information of the LCD touch panel. For more detailed information of better using this chip, please refer to its datasheet which is available on manufacturer’s website or under the /datasheet folder of the system CD.

**Table 4-21 Pin names and descriptions of the MPU-9250**

Signal Name	FPGA Pin Number	Description	I/O Standard
MPU_INT	PIN_E26	Interrupt digital output	1.8V
FPGA_I2C_SCL	PIN_M1	I2C serial clock	1.2V
FPGA_I2C_SDA	PIN_M4	I2C serial data	1.2V

# HPS Fabric Components

This section introduces the interfaces connected to the HPS section of the Arria 10 SoC FPGA. Users can access these interfaces via the HPS processor.

## 5.1 User Push-buttons and LEDs

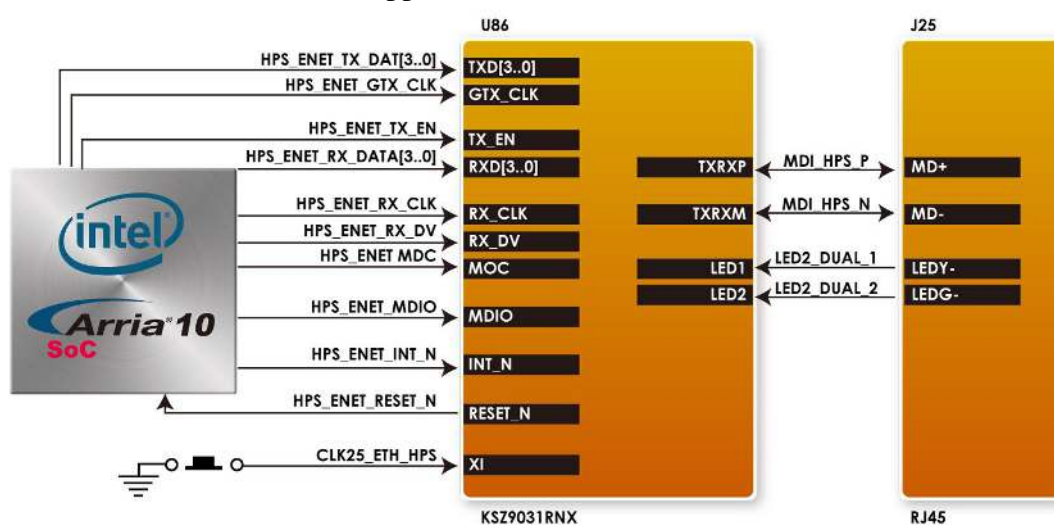
Similar to the FPGA, the HPS also has its set of switches, buttons, LEDs, and other interfaces connected exclusively. Users can control these interfaces to monitor the status of HPS. **Table 5-1** gives the pin assignment of all the LEDs, switches and push-buttons.

**Table 5-1 Pin Assignment of LEDs, Switches and Push-buttons**

Signal Name	HPS Pin Number	Function	I/O Standard
HPS_KEY	PIN_A29	I/O	1.8 V
HPS_LED	PIN_D29	I/O	1.8 V

## 5.2 Gigabit Ethernet

The board supports Gigabit Ethernet transfer by an external Micrel KSZ9031RNX PHY chip and HPS Ethernet MAC function. The KSZ9031RNX chip with integrated 10/100/1000 Mbps Gigabit Ethernet transceiver also supports RGMII MAC interface. **Figure 5-1** shows the connections between the HPS, Gigabit Ethernet PHY, and RJ-45 connector. The pin assignment associated with Gigabit Ethernet interface is listed in **Table 5-2**. More information about the KSZ9031RNX PHY chip and its datasheet, as well as the application notes, is available on the manufacturer's website.



**Figure 5-1 Connections between the HPS and Gigabit Ethernet**

**Table 5-2 Pin Assignment of Gigabit Ethernet PHY**

Signal Name	FPGA Pin Number	Description	I/O Standard
HPS_ENET_GTX_CLK	PIN_F25	GMII Transmit Clock	1.8V
HPS_ENET_MDC	PIN_D24	Management Data Clock Reference	1.8V
HPS_ENET_MDIO	PIN_C24	Management Data	1.8V
HPS_ENET_RX_CLK	PIN_K22	GMII and MII receive clock	1.8V
HPS_ENET_RX_DATA[0]	PIN_H23	GMII and MII receive data[0]	1.8V
HPS_ENET_RX_DATA[1]	PIN_J23	GMII and MII receive data[1]	1.8V
HPS_ENET_RX_DATA[2]	PIN_F24	GMII and MII receive data[2]	1.8V
HPS_ENET_RX_DATA[3]	PIN_G24	GMII and MII receive data[3]	1.8V
HPS_ENET_RX_DV	PIN_L22	GMII and MII receive data valid	1.8V
HPS_ENET_TX_DATA[0]	PIN_H24	MII transmit data[0]	1.8V
HPS_ENET_TX_DATA[1]	PIN_J24	MII transmit data[1]	1.8V
HPS_ENET_TX_DATA[2]	PIN_M22	MII transmit data[2]	1.8V
HPS_ENET_TX_DATA[3]	PIN_M21	MII transmit data[3]	1.8V
HPS_ENET_TX_EN	PIN_G25	GMII and MII transmit enable	1.8V

There are four LEDs, two green LEDs(LEDG) and two yellow LEDs(LEDY), which represent the status of Ethernet PHY (KSZ9031RNX). The LED control signals are connected to the LEDs on the RJ45 connector. The state and definition of LEDG and LEDY are listed in **Table 5-3**. For instance, the connection from board to Gigabit Ethernet is established once the LEDG lights on.

**Table 5-3 State and Definition of LED Mode Pins**

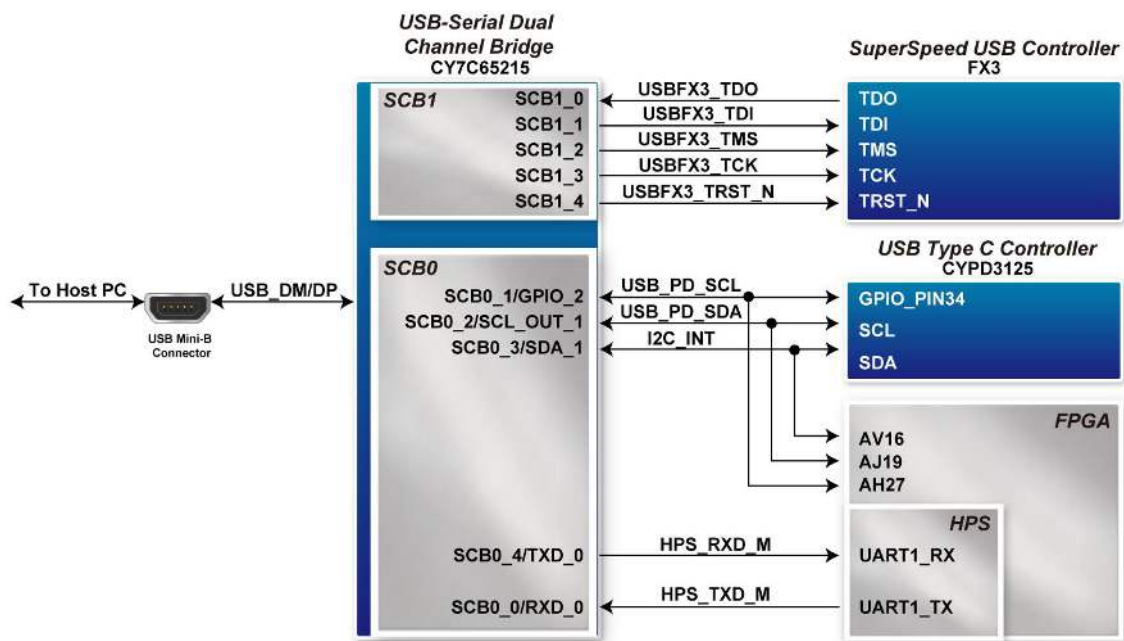
LED (State)		LED (Definition)		Link /Activity
LEDG	LEDY	LEDG	LEDY	
H	H	OFF	OFF	Link off
L	H	ON	OFF	1000 Link / No Activity
Toggle	H	Blinking	OFF	1000 Link / Activity (RX, TX)
H	L	OFF	ON	100 Link / No Activity
H	Toggle	OFF	Blinking	100 Link / Activity (RX, TX)
L	L	ON	ON	10 Link/ No Activity
Toggle	Toggle	Blinking	Blinking	10 Link / Activity (RX, TX)

## 5.3 UART to USB

An USB to Serial device (Cypress: CY7C65215) is used on the HAN Pilot Platform to connect to other on-board devices through JTAG / UART / I2C interface. Let Host PC can communicate with these devices through the USB interface (See [Figure 5-2](#)).

There are two serial communication blocks (SCB) in CY7C65215, in which SCB0 is used to connect HPS UART channel or USB PD controller (CYPD3125) I2C bus. The default setting is preset to HPS UART function, so HPS UART can communicate with Host PC via this channel. Another option is the USB Type-C controller's I2C bus. This is reserved for the user to configure the firmware of the USB Type-C controller function from the Host PC. The channel is also connected to the FPGA at the same time, so that the FPGA can read the registers in the USB Type-C controller to monitor the state. If user wants to change the SCB0 to I2C, it needs to be modified from the setting software on the host PC.

The other channel of the CY7C65215 SCB1 is used as the JTAG interface, which is connected to the USB FX3 device, allowing the user to debug the FX3 chip via the JTAG interface through the Host PC software. [Table 5-4](#) lists the pin assignment of USB to serial device connected to the FPGA.



**Figure 5-2** Connections between the HPS and USB Mini-B connector

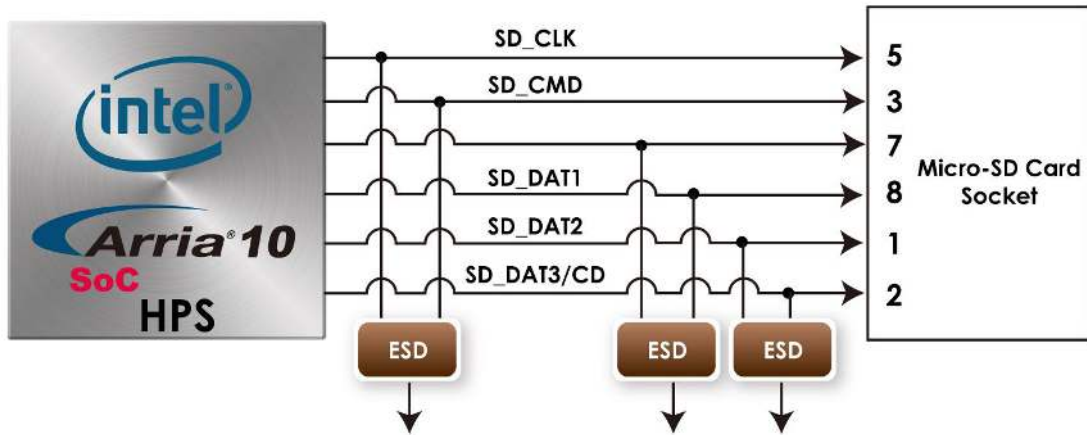
**Table 5-4** Pin Assignment of UART Interface

Signal Name	FPGA Pin Number	Description	I/O Standard
USB_PD_SCL	PIN_AJ19	I2C Serial Clock	1.8V
USB_PD_SDA	PIN_AV16	I2C Serial Data	1.8V
I2C_INT	PIN_AH27	inter-integrated circuit	1.8V
HPS_RXD_M(HPS_DIO_13)	PIN_L20	HPS UART Receiver	1.8V

HPS_TXD_M(HPS_DIO_12)	PIN_J19	HPS UART Transmitter	1.8V
-----------------------	---------	----------------------	------

## 5.4 Micro SD Card Socket

The board supports Micro SD card interface with x4 data lines. It serves not only an external storage for the HPS, but also an alternative boot option for DE10-Standard board. **Figure 5-3** shows signals connected between the HPS and Micro SD card socket to the HPS.



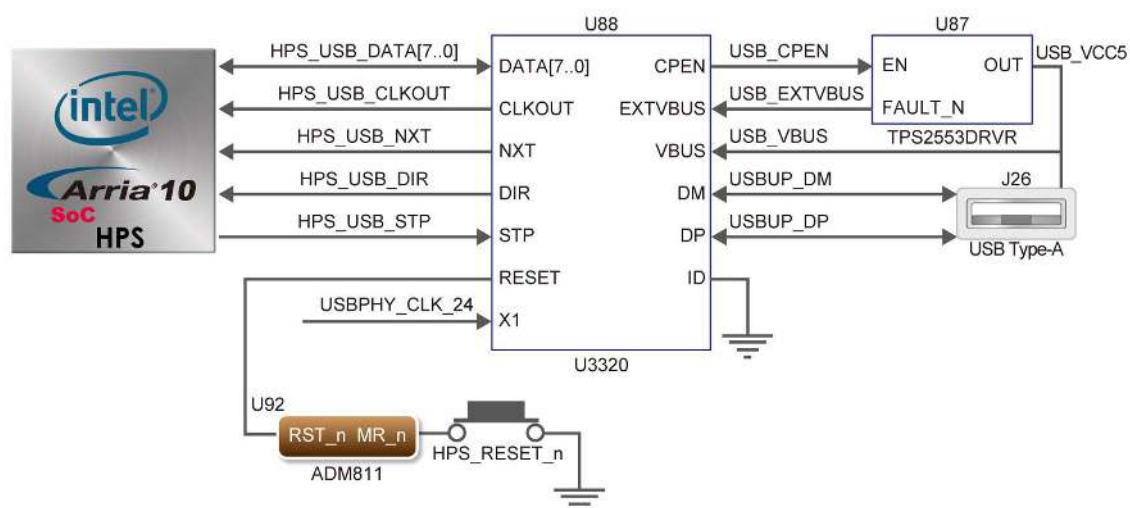
**Figure 5-3** Connections between the FPGA and SD card socket

**Table 5-5** Pin Assignment of Micro SD Card Socket

Signal Name	FPGA Pin Number	Description	I/O Standard
SD_CLK	PIN_K18	HPS SD Clock	1.8V
SD_CMD	PIN_F22	HPS SD Command Line	1.8V
SD_DATA0	PIN_J18	HPS SD Data[0]	1.8V
SD_DATA1	PIN_E23	HPS SD Data[1]	1.8V
SD_DATA2	PIN_G21	HPS SD Data[2]	1.8V
SD_DATA3	PIN_H21	HPS SD Data[3]	1.8V

## 5.5 USB OTG

The board has one USB 2.0 type-A port with a SMSC USB3320 controller. The SMSC USB3320 device in 32-pin QFN RoHS Compliant package. This device supports UTMI+ Low Pin Interface (ULPI), which communicates with the USB 2.0 controller in HPS. The PHY operates in Host mode by connecting the ID pin of USB3320 to ground. When operating in Host mode, the device is powered by the USB type-A port. **Figure 5-4** shows the connections of USB PTG PHY to the HPS. **Table 5-6** lists the pin assignment of USB OTG PHY to the HPS.



**Figure 5-4 Connections between the HPS and USB OTG PHY**

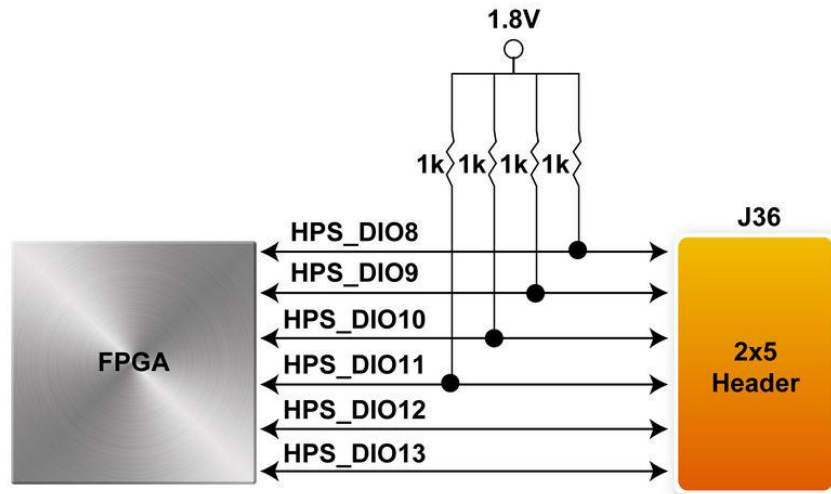
**Table 5-6 Pin Assignment of USB OTG PHY**

Signal Name	FPGA Pin Number	Description	I/O Standard
HPS_USB_CLKOUT	PIN_L25	60MHz Reference Clock Output	1.8V
HPS_USB_DATA[0]	PIN_K25	HPS USB_DATA[0]	1.8V
HPS_USB_DATA[1]	PIN_G26	HPS USB_DATA[1]	1.8V
HPS_USB_DATA[2]	PIN_E27	HPS USB_DATA[2]	1.8V
HPS_USB_DATA[3]	PIN_F27	HPS USB_DATA[3]	1.8V
HPS_USB_DATA[4]	PIN_L24	HPS USB_DATA[4]	1.8V
HPS_USB_DATA[5]	PIN_M24	HPS USB_DATA[5]	1.8V
HPS_USB_DATA[6]	PIN_K23	HPS USB_DATA[6]	1.8V
HPS_USB_DATA[7]	PIN_L23	HPS USB_DATA[7]	1.8V
HPS_USB_DIR	PIN_J25	Direction of the Data Bus	1.8V
HPS_USB_NXT	PIN_H26	Throttle the Data	1.8V
HPS_USB_STP	PIN_M25	Stop Data Stream on the Bus	1.8V

## 5.6 GPIO Header

There is a 2x5 pin header(2.54mm) on the HAN Pilot Platform which connected to six FPGA HPS fabric GPIOs. These I/Os can be used as GPIO that are directly controlled by HPS. Or it can be used as SPI interface (HPS\_DIO[11:8]), using the SPI master controller in HPS to communicate with other SPI devices. **Table 5-7** shows the pin assignment of the HPS GPIO header.





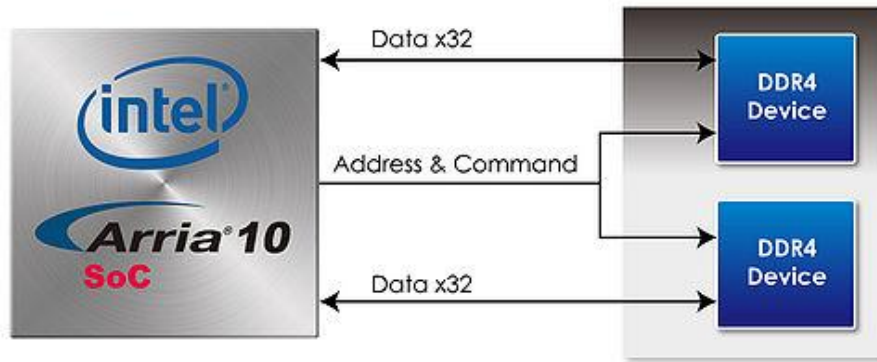
**Figure 5-5 Connection between FPGA and HPS GPIO Header**

**Table 5-7 Pin Assignment of GPIO Header**

Signal Name	FPGA Number	Pin	Description	I/O Standard
HPS_DIO8	PIN_D23		HPS GPIO 8; SPIM0_CLK	1.8V
HPS_DIO9	PIN_C23		HPS GPIO 9; SPIM0_MISO	1.8V
HPS_DIO10	PIN_F23		HPS GPIO 10; SPIM0_CLK	1.8V
HPS_DIO11	PIN_G22		HPS GPIO 11; SPIM0_SS0	1.8V
HPS_DIO12	PIN_J19		HPS GPIO 12; Reserve	1.8V
HPS_DIO13	PIN_L20		HPS GPIO 13; Reserve	1.8V

## 5.7 DDR4 (HPS)

The board supports 1GB of DDR4 SDRAM comprising of two x16 bit DDR4 devices on the HPS **shared I/O Banks** (Bank 2J and 2K). The signals are connected to the dedicated HPS external memory interface and the target speed is 1067 MHz. If users do not include any HPS external memory interface in their system, users can use these DDR4 devices by FPGA fabric. Figure 3 26 shows the connections between the DDR4 and Arria 10 SoC FPGA. Table 3 18 lists the pin assignment of DDR4 and its description with I/O standard.



**Figure 5-6 Connection between FPGA and HPS DDR4 devices**

FPGA Pin Number	Signal Name	Description	I/O Standard
PIN_M27	DDR4H_REFCLK_p	DDR4 A port Reference Clock	LVDS
PIN_U27	DDR4H_A[0]	Address [0]	SSTL-12
PIN_V27	DDR4H_A[1]	Address [1]	SSTL-12
PIN_P28	DDR4H_A[2]	Address [2]	SSTL-12
PIN_N27	DDR4H_A[3]	Address [3]	SSTL-12
PIN_N26	DDR4H_A[4]	Address [4]	SSTL-12
PIN_P26	DDR4H_A[5]	Address [5]	SSTL-12
PIN_R26	DDR4H_A[6]	Address [6]	SSTL-12
PIN_R25	DDR4H_A[7]	Address [7]	SSTL-12
PIN_R28	DDR4H_A[8]	Address [8]	SSTL-12
PIN_R27	DDR4H_A[9]	Address [9]	SSTL-12
PIN_T25	DDR4H_A[10]	Address [10]	SSTL-12
PIN_U25	DDR4H_A[11]	Address [11]	SSTL-12
PIN_K26	DDR4H_A[12]	Address [12]	SSTL-12
PIN_G29	DDR4H_A[13]	Address [13]	SSTL-12
PIN_H28	DDR4H_A[14]	Address [14]/WE_n	SSTL-12
PIN_K28	DDR4H_A[15]	Address [15]/CAS_n	SSTL-12
PIN_L28	DDR4H_A[16]	Address [16]/RAS_n	SSTL-12
PIN_AU6	DDR4H_BA[0]	Bank Select [0]	SSTL-12
PIN_AP8	DDR4H_BA[1]	Bank Select [1]	SSTL-12
PIN_AN8	DDR4H_BG[0]	Bank Group Select[0]	SSTL-12
PIN_AJ14	DDR4H_BG[1]	Bank Group Select[1]	SSTL-12

PIN_U26	DDR4H_CK	Clock p	DIFFERENTIAL 1.2-V SSTL
PIN_V26	DDR4H_CK_n	Clock n	DIFFERENTIAL 1.2-V SSTL
PIN_V28	DDR4H_CKE	Clock Enable pin	SSTL-12
PIN_A20	DDR4H_DQS[0]	Data Strobe p[0]	DIFFERENTIAL 1.2-V POD
PIN_B17	DDR4H_DQS[1]	Data Strobe p[1]	DIFFERENTIAL 1.2-V POD
PIN_L15	DDR4H_DQS[2]	Data Strobe p[2]	DIFFERENTIAL 1.2-V POD
PIN_F18	DDR4H_DQS[3]	Data Strobe p[3]	DIFFERENTIAL 1.2-V POD
PIN_B20	DDR4H_DQS_n[0]	Data Strobe n[0]	DIFFERENTIAL 1.2-V POD
PIN_C17	DDR4H_DQS_n[1]	Data Strobe n[1]	DIFFERENTIAL 1.2-V POD
PIN_M15	DDR4H_DQS_n[2]	Data Strobe n[2]	DIFFERENTIAL 1.2-V POD
PIN_F19	DDR4H_DQS_n[3]	Data Strobe n[3]	DIFFERENTIAL 1.2-V POD
PIN_H18	DDR4H_DBI_n[0]	Data Bus Inversion [0]	1.2-V POD
PIN_E18	DDR4H_DBI_n[1]	Data Bus Inversion [1]	1.2-V POD
PIN_D16	DDR4H_DBI_n[2]	Data Bus Inversion [2]	1.2-V POD
PIN_E20	DDR4H_DBI_n[3]	Data Bus Inversion [3]	1.2-V POD
PIN_AJ9	DDR4H_DQ[0]	Data [0]	1.2-V POD
PIN_AG11	DDR4H_DQ[1]	Data [1]	1.2-V POD
PIN_AF9	DDR4H_DQ[2]	Data [2]	1.2-V POD
PIN_AG12	DDR4H_DQ[3]	Data [3]	1.2-V POD
PIN_AG9	DDR4H_DQ[4]	Data [4]	1.2-V POD
PIN_AF12	DDR4H_DQ[5]	Data [5]	1.2-V POD
PIN_AJ10	DDR4H_DQ[6]	Data [6]	1.2-V POD
PIN_AG10	DDR4H_DQ[7]	Data [7]	1.2-V POD
PIN_AL9	DDR4H_DQ[8]	Data [8]	1.2-V POD
PIN_AH9	DDR4H_DQ[9]	Data [9]	1.2-V POD

PIN_AK6	DDR4H_DQ[10]	Data [10]	1.2-V POD
PIN_AK7	DDR4H_DQ[11]	Data [11]	1.2-V POD
PIN_AH8	DDR4H_DQ[12]	Data [12]	1.2-V POD
PIN_AH7	DDR4H_DQ[13]	Data [13]	1.2-V POD
PIN_AJ8	DDR4H_DQ[14]	Data [14]	1.2-V POD
PIN_AE11	DDR4H_DQ[15]	Data [15]	1.2-V POD
PIN_AT4	DDR4H_DQ[16]	Data [16]	1.2-V POD
PIN_AM7	DDR4H_DQ[17]	Data [17]	1.2-V POD
PIN_AP5	DDR4H_DQ[18]	Data [18]	1.2-V POD
PIN_AL5	DDR4H_DQ[19]	Data [19]	1.2-V POD
PIN_AM5	DDR4H_DQ[20]	Data [20]	1.2-V POD
PIN_AM6	DDR4H_DQ[21]	Data [21]	1.2-V POD
PIN_AM4	DDR4H_DQ[22]	Data [22]	1.2-V POD
PIN_AR5	DDR4H_DQ[23]	Data [23]	1.2-V POD
PIN_AP1	DDR4H_DQ[24]	Data [24]	1.2-V POD
PIN_AR3	DDR4H_DQ[25]	Data [25]	1.2-V POD
PIN_AN3	DDR4H_DQ[26]	Data [26]	1.2-V POD
PIN_AR1	DDR4H_DQ[27]	Data [27]	1.2-V POD
PIN_AU2	DDR4H_DQ[28]	Data [28]	1.2-V POD
PIN_AP4	DDR4H_DQ[29]	Data [29]	1.2-V POD
PIN_AR2	DDR4H_DQ[30]	Data [30]	1.2-V POD
PIN_AU1	DDR4H_DQ[31]	Data [31]	1.2-V POD
PIN_AF10	DDR4H_DM[0]	DDR3 Data Mask[0]	1.2-V POD
PIN_AL8	DDR4H_DM[1]	DDR3 Data Mask[1]	1.2-V POD
PIN_AN7	DDR4H_DM[2]	DDR3 Data Mask[2]	1.2-V POD
PIN_AN4	DDR4H_DM[3]	DDR3 Data Mask[3]	1.2-V POD
PIN_AJ13	DDR4H_CS_n[0]	Chip Select	SSTL-12
PIN_Y26	DDR4H_RESET_n	Chip Reset	1.2 V
PIN_Y28	DDR4H_ODT	On Die Termination	SSTL-12
PIN_T27	DDR4H_PAR	Command and Address Parity Input	SSTL-12
PIN_A23	DDR4H_ALERT_n	Register ALERT_n output	SSTL-12
PIN_Y25	DDR4H_ACT_n	Activation Command Input	SSTL-12

PIN_J26	DDR4H_RZQ	External reference ball for output drive calibration	1.2 V
---------	-----------	--	-------

## System Clocks

Figure 6-1 shows the Clock Net connected to FPGA on HAN Pilot Platform.

The Si5350c provides the fixed system frequencies to FPGA, HPS and other important components. There are four 50 MHz connected to the dedicated clock pins of the FPGA, which can be used by PLL for clock multiplier or frequency division. In addition, there are Programmable PLL (CDCM6280, BGA/FXXXXX) available for providing the clocks to the peripherals on the board, such as HDMI and communication interfaces. There is a default clock when power on, it also supports the users to change the frequency via I2C interface for special requirement.

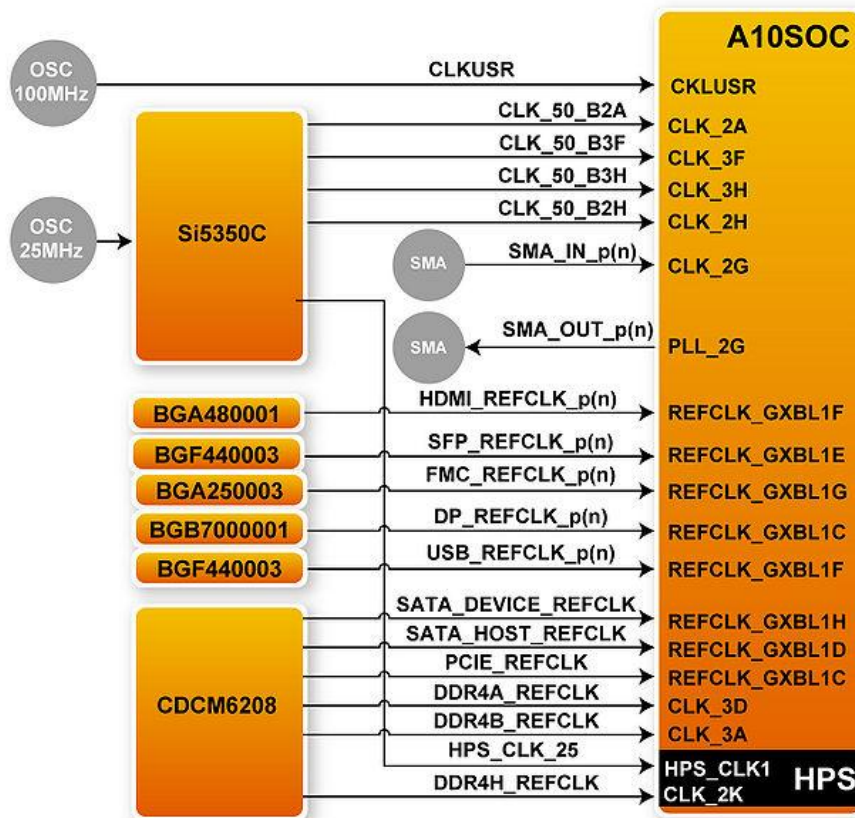


Figure 6-1 System Clock in the HAN Pilot Platform



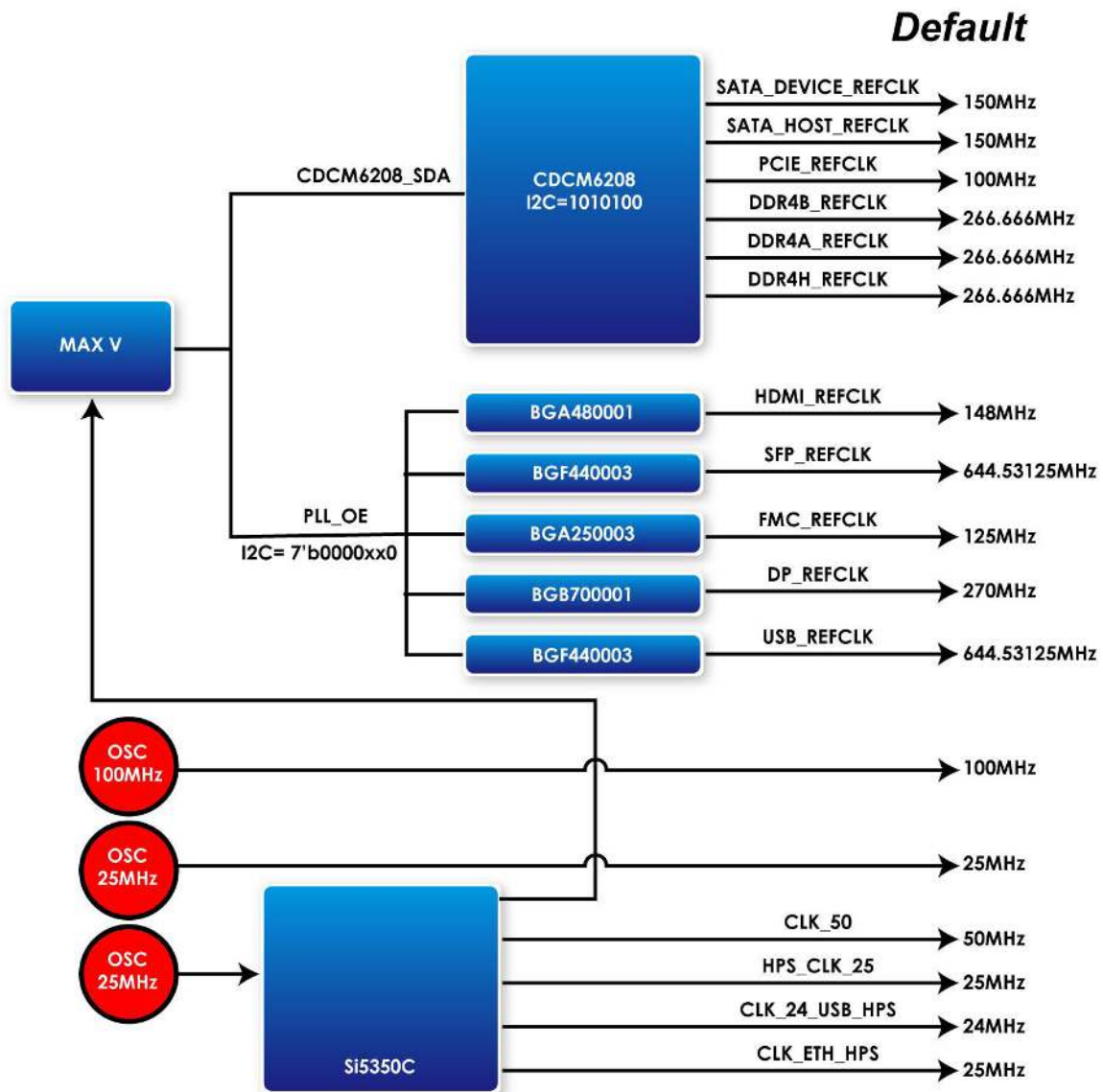


Figure 6-2 The default settings for different PLLs

Table 6-1 Clock pin input to the FPGA

Source	Schematic Signal Name	Default Frequency	I/O Standard	Arria 10 GX Pin Number	Application
U41 Si5350C	CLK_50_B2A	50.0 MHz	1.8V	PIN_AW16	User application
	CLK_50_B2H		1.8V	PIN_AR23	User application
	CLK_50_B3F		1.8V	PIN_F3	User application
	CLK_50_B3H		1.8V	PIN_D11	User application
Y5 OSC	OSC_100_CLKUSR	100MHz	1.8V	PIN_AJ18	Clock for configuration and transceiver calibration
U80 BGA4800001	HDMI_REFCLK_p	148.5Mhz	LVDS	PIN_V31	HDMI reference clock
U25	SFP_REFCLK_p	644.53125	LVDS	PIN_AD31	SFP reference clock

BGF4400003		Mhz			
U36 BGA2500003	FMC_REFCLK_p	125Mhz	LVDS	PIN_T31	FMC connector reference clock
U35 BGB7000001	DP_REFCLK_p	270Mhz	LVDS	PIN_AM31	Display Port reference clock
U77 BGF4400003	USB_REFCLK_p	644.53125 MHz	LVDS	PIN_AB31	USB 3.0 interface reference clock
U82 CDCM6028	SATA_DEVICE_REFCLK_p	150MHz	LVDS	PIN_M31	SATA device reference clock
	SATA_HOST_REFCLK_p	150 MHz	LVDS	PIN_AF31	SATA host reference clock
	OB_PCIE_REFCLK_p	100 MHz	LVDS	PIN_AK31	PCIE reference clock
	DDR4A_REFCLK_p	266.666 MHz	LVDS	PIN_AB12	DDR4 reference clock for DDR4 SODIMM
	DDR4B_REFCLK_p	266.666 MHz	LVDS	PIN_AU7	DDR4 reference clock for DDR4 Bank B
	DDR4H_REFCLK_p	266.666 MHz	LVDS	PIN_M27	DDR4 reference clock for DDR4 Bank H



# *HAN Pilot Platform System*

## *Builder*

---

This chapter describes how users can create a custom design project with the tool named HAN Pilot Platform System Builder.

### **8.1 Introduction**

The System Builder is a Windows based software utility. It is designed to help users create a Quartus Prime project for the FPGA board within minutes. The Quartus Prime project files generated include:

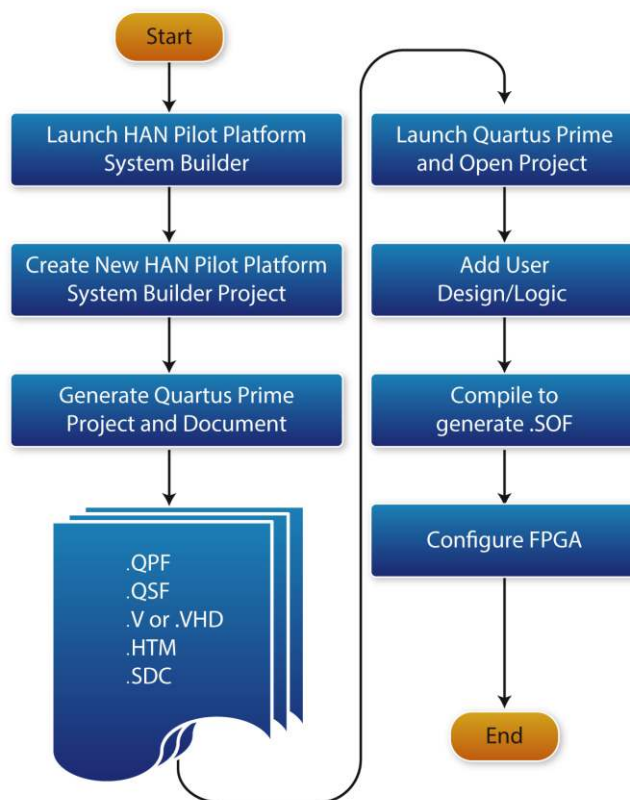
- Quartus Prime Project File (.qpf)
- Quartus Prime Setting File (.qsf)
- Top-Level Design File (.v)
- Synopsis Design Constraints file (.sdc)
- Pin Assignment Document (.htm)

The above files generated by the HAN Pilot Platform System Builder can also prevent occurrence of situations that are prone to compilation error when users manually edit the top-level design file or place pin assignment. The common mistakes users may encounter are:

- Board is damaged due to incorrect bank voltage setting or pin assignment
- Board is malfunctioned because of wrong device chosen, declaration of pin location or direction is incorrect or forgotten
- Performance degradation due to improper pin assignment

### **8.2 General Design Flow**

This section will introduce the general design flow to build a project for the FPGA board via the System Builder. The general design flow is illustrated in the **Figure 8-1**.



**Figure 8-1 The general design flow of building a project**

Users should launch System Builder and create a new project according to their design requirements. When users complete the settings, the System Builder will generate two major files which include top-level design file (.v) and the Quartus Prime setting file(.qsf).

The top-level design file contains top-level Verilog wrapper for users to add their own design/logic. The Quartus Prime setting file contains information such as FPGA device type, top-level pin assignment, and I/O standard for each user-defined I/O pin.

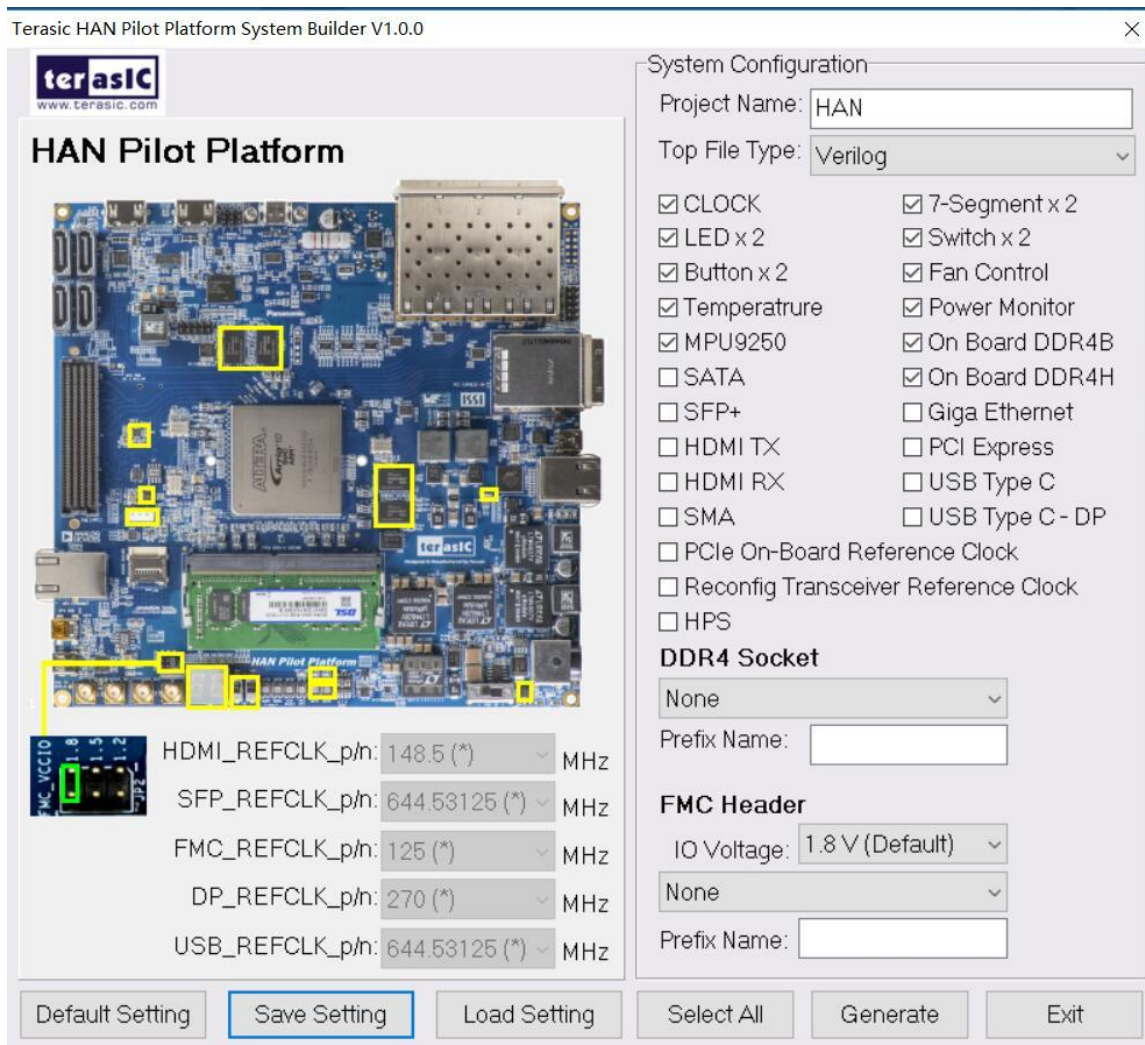
Finally, Quartus Prime programmer must be used to download SOF file to the FPGA board using JTAG interface.

### **8.3 Using HAN Pilot Platform System Builder**

This section provides the detailed procedures on how to use the HAN Pilot Platform System Builder.

#### **■ Install and Launch the HAN Pilot Platform System Builder**

The HAN Pilot Platform System Builder is located in the directory: “Tools\SystemBuilder” of the HAN Pilot Platform System CD. Users can copy the entire folder to a host computer without installing the utility. A window will pop up, as shown in **Figure 8-2**, after executing the HAN Pilot Platform SystemBuilder.exe on the host computer.

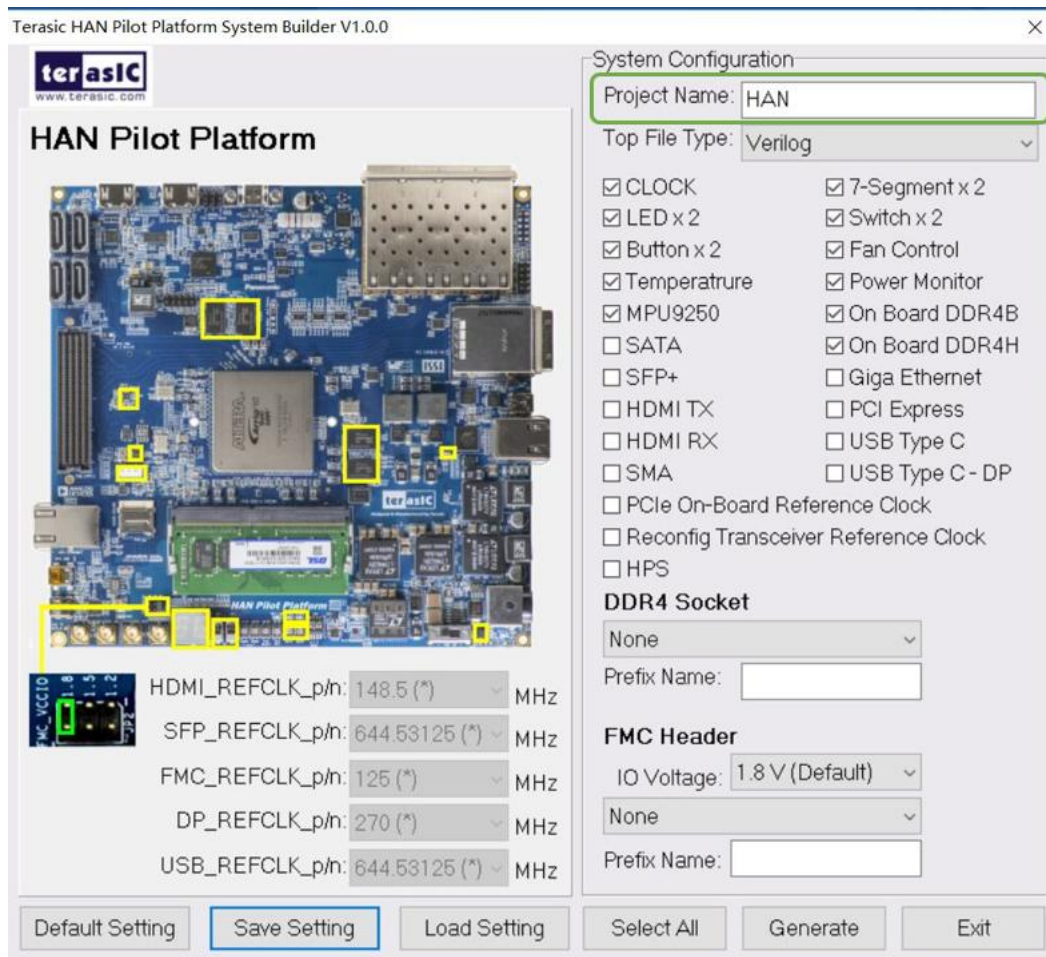


**Figure 8-2 The GUI of HAN Pilot Platform System Builder**

## ■ Enter Project Name

Enter the project name in the circled area, as shown in [Figure 8-3](#). The project name typed in will be assigned automatically as the name of your top-level design entity.

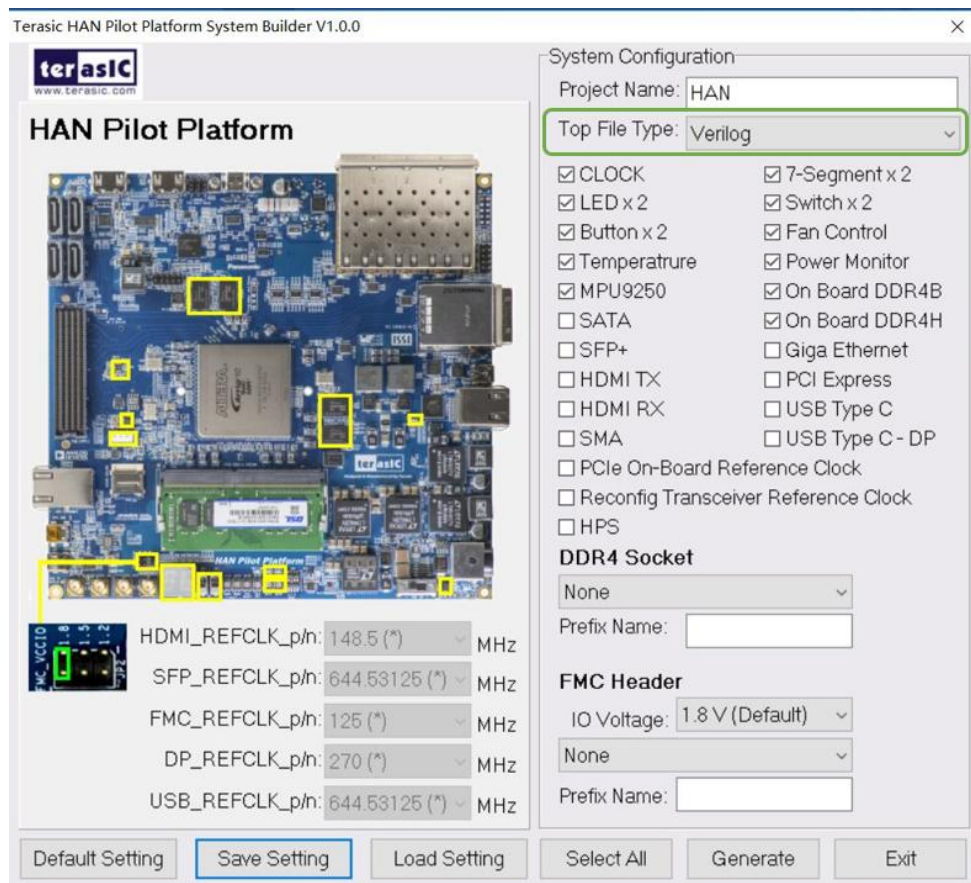




**Figure 8-3 Project Name in the System Builder window**

■ **Select Top File Type**

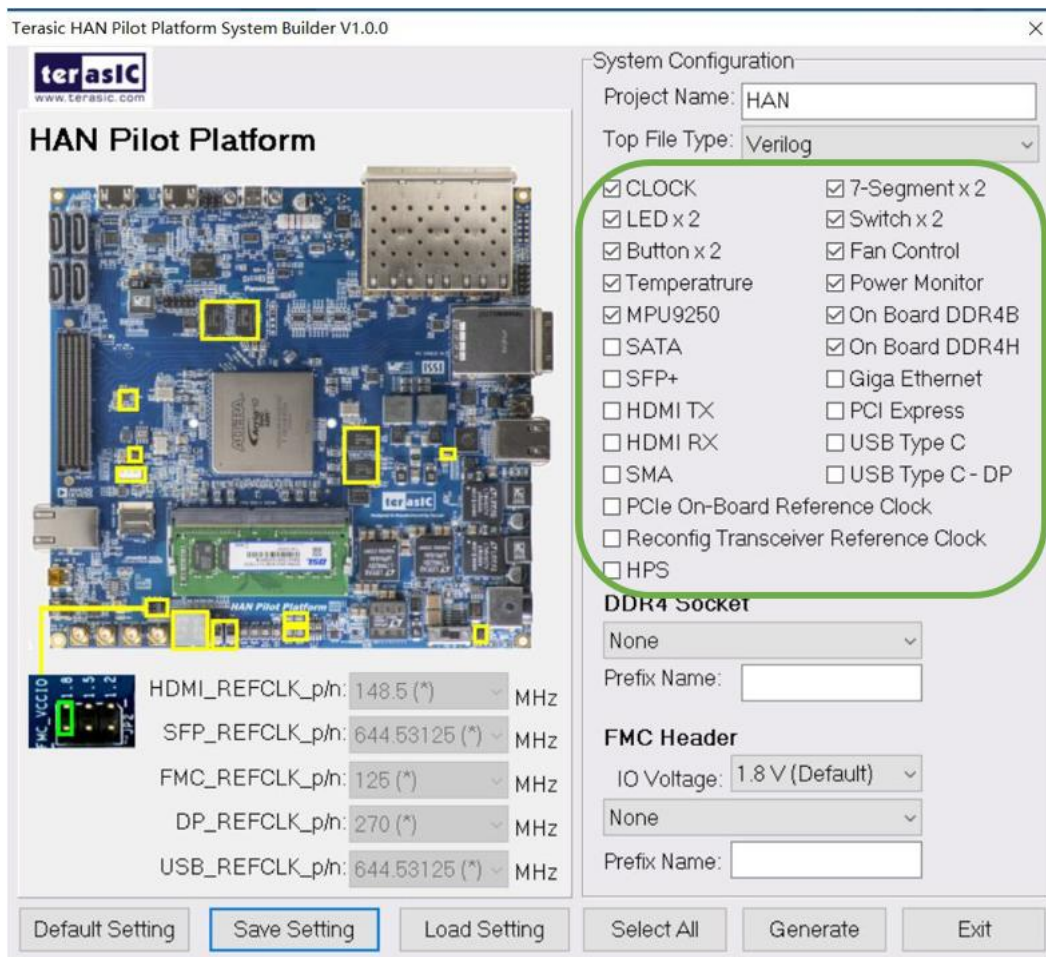
The system builder can generate Verilog or VHDL Quartus top file according to users' requirement. Users can select their desired file type in the Top File Type list-box shown in **Figure 8-4**.



**Figure 8-4 Top File Type in the System Builder window**

## ■ System Configuration

Users are given the flexibility of enabling their choices of components connected to the FPGA under System Configuration, as shown in **Figure 8-5**. Each component of the FPGA board is listed to be enabled or disabled according to users' needs. If a component is enabled, the System Builder will automatically generate the associated pin assignments including its pin name, pin location, pin direction, and I/O standards. Note: The pin assignments for some components (e.g. DDR4 and SFP+) require associated controller codes in the Quartus project or it would result in compilation error. Hence please do not select them if they are not needed in the design.

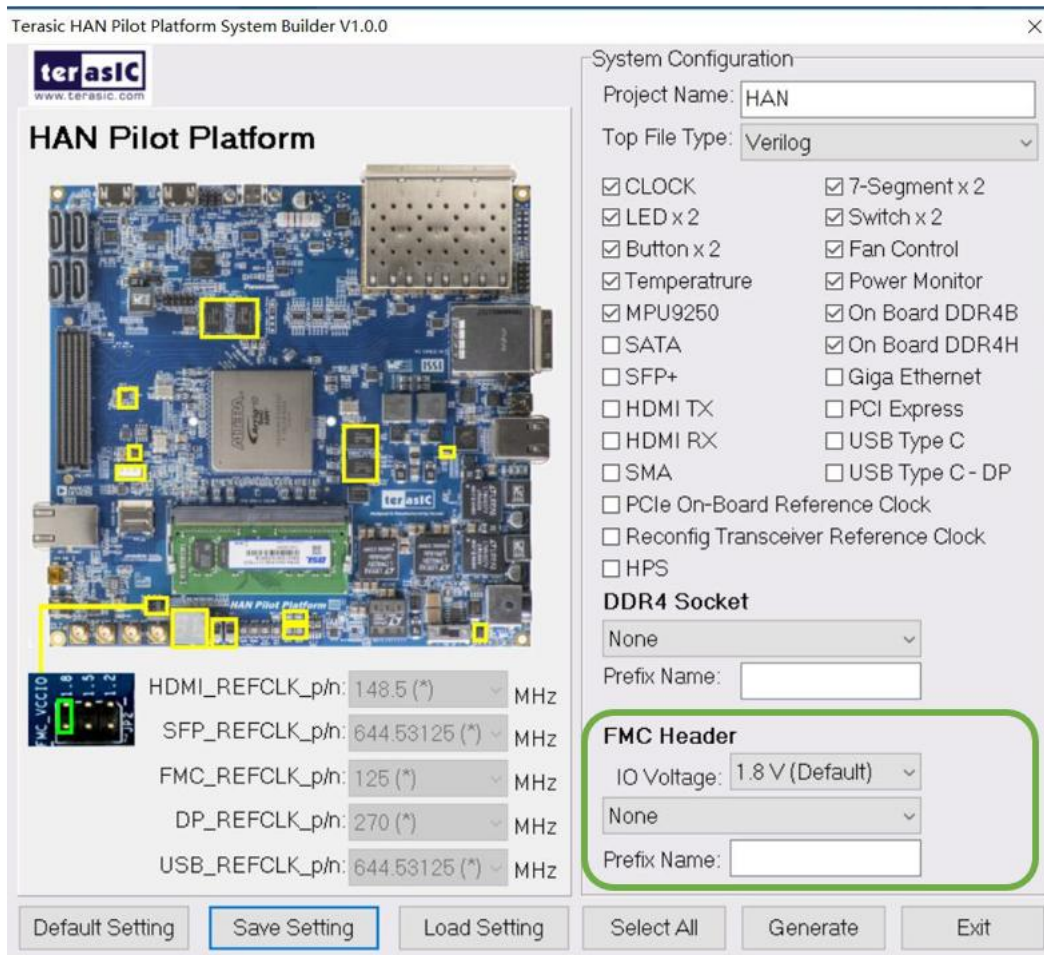


**Figure 8-5 System Configuration group**

## ■ FMC Expansion

If users connect any compatible Terasic FMC-based daughter cards to the FMC connector on HAN Pilot Platform, the HAN Pilot Platform System Builder can generate a project that include the corresponding module, as shown in **Figure 8-6**. It will also generate the associated pin assignment automatically, including pin name, pin location, pin direction, and I/O standard.

The “Prefix Name” is an optional feature that denotes the pin name of the daughter card assigned in your design. Users may leave this field blank.



**Figure 8-6 FMC expansion group**

## ■ Programmable Clock Generator

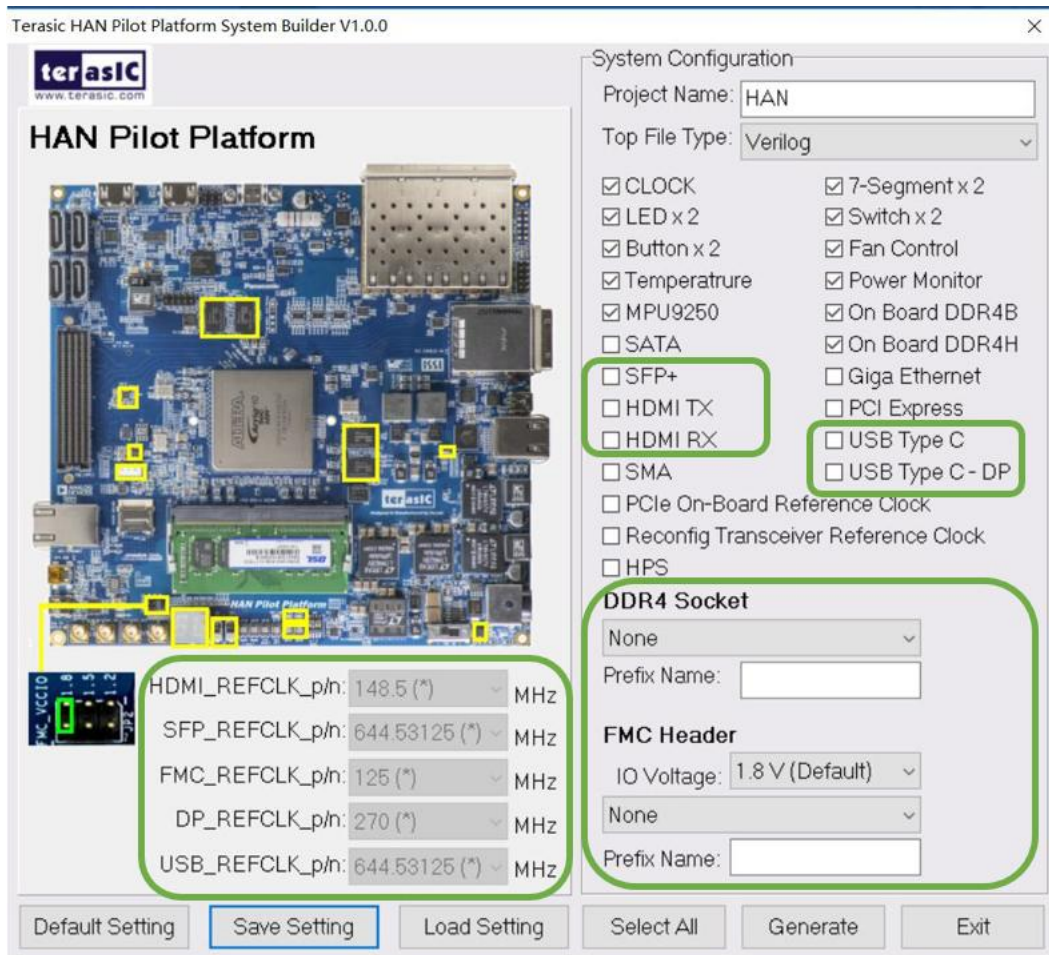
There are some oscillators on-board (Si5350C, CDCM6208) that provide reference clocks for the following signals:

- HDMI\_REFCLK
- SFP\_REFCLK
- FMC\_REFCLK
- DP\_REFCLK
- USB\_REFCLK

To use these clocks, users can select the desired frequency on the Programmable Oscillator group, as shown in **Figure 8-7**. DDR4, or SFP+ must be checked before users can start to specify the desired frequency in the programmable oscillators. As the Quartus project is created, System Builder automatically generates the associated controller according to users' desired frequency in Verilog which facilitates users' implementation as no additional control code is required to configure the programmable oscillator.

Note: If users need to dynamically change the frequency, they would need to modify the generated control code themselves.

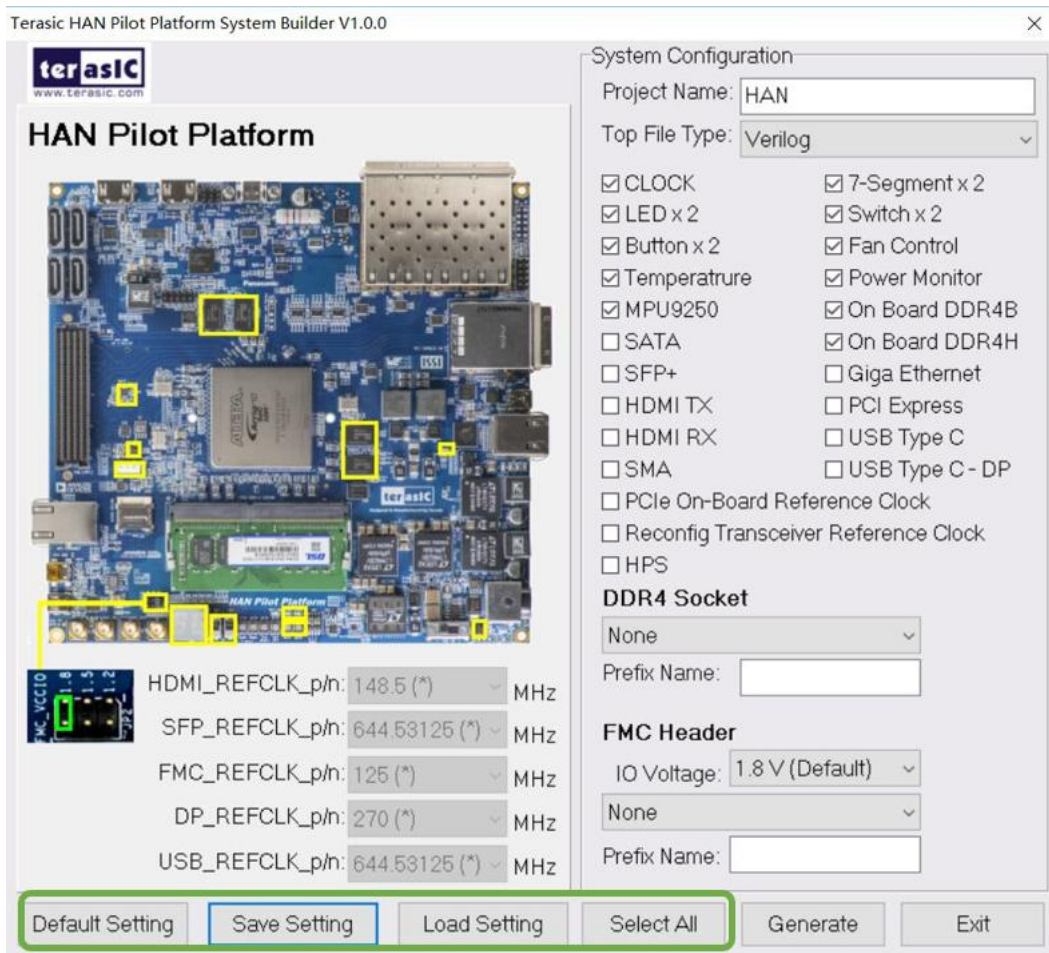




**Figure 8-7 External programmable oscillators**

## ■ Project Setting Management

The System Builder also provides functions to restore default setting, load a setting, and save board configuration file, as shown in [Figure 8-8](#). Users can save the current board configuration information into a .cfg file and load it into the System Builder.



**Figure 8-8 Project Settings**

## ■ Project Generation

When users press the Generate button, the HAN Pilot Platform System Builder will generate the corresponding Quartus Prime files and documents as listed in [Table 8-1](#).

**Table 8-1 The files generated by HAN Pilot Platform System Builder**

No.	File Name	Descriptions
1	<Project name>.v	Top Verilog Quartus Prime File
2	<Project name>.qpf	Quartus Prime Project File
3	<Project name>.qsf	Quartus Prime Setting File
4	<Project name>.sdc	Quartus Prime Synopsis Design Constraints File
5	<Project name>.htm	Pin Assignment Document

Users can use Quartus Prime software to add custom logic into the project and compile the project to generate the SRAM Object File. (.sof).



### ■ Revision History

<i>Version</i>	<i>Date</i>	<i>Change Log</i>
V1.0	10/24, 2018	Initial Version (Preliminary)
V1.1	7/5, 2019	Modify FPP x32 mode MSEL setting to 000
V1.2	08/16, 2019	Delete HPS boot from NAND and QSPI flash
V1.3	09/06,2019	Add note for PRSNT_M2C_L pin in section 4.9
V1.4	09/12,2019	Modify FMC section
V1.5	03/26,2020	Add Table 6-1
V1.6	08/07,2020	Modify Figure 2-3
V1.7	12/16,2020	Modify section 4.6

### ■ Copyright Statement

Copyright © Terasic Inc. All rights reserved.