

NRG

Epoxy sealed radial lead NTC thermistor



Product features

- Epoxy sealed radial NTC thermistor
- Temperature sensing, quick response time
- Bead with ring lug
- Wide resistance range 1 kΩ to 470 kΩ
- Non-linear change in resistance vs temperature

Packaging information

- Bulk, Type 3: 250 parts per poly bag
- Bulk, Others: 500 parts per poly bag

Applications

- Industrial Process Control
- Commercial appliances
- Battery, supercapacitor and energy storage systems
- Uninterruptible power supplies
- Consumer appliances
- Medical devices
- Heating, ventilation and air conditioning, Refrigeration (HVACR)
- Food service equipment
- IoT
- White goods/household appliances
- Computer and peripheral products

Environmental compliance and general specifications



Table 1. Part numbering

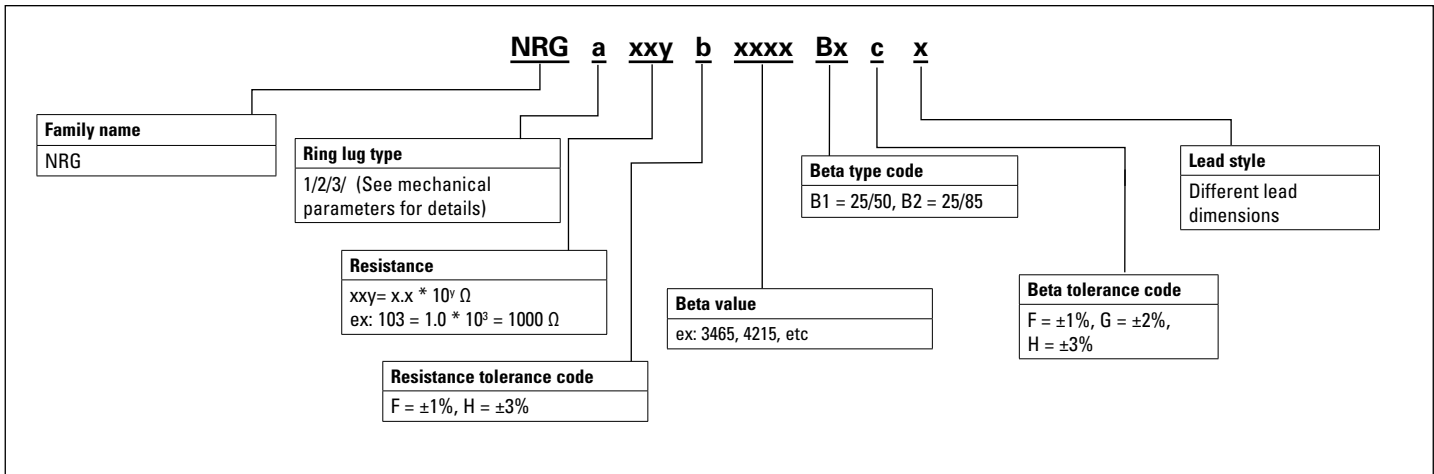

See electrical specification table for option details



Powering Business Worldwide

Mechanical parameters- mm

Lug type 1

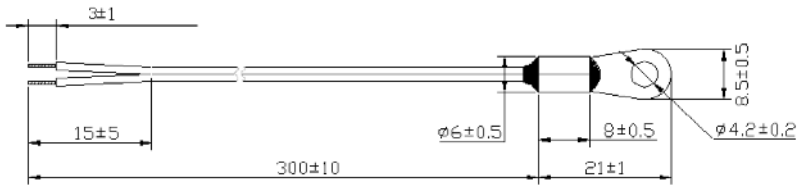

Lug type 2

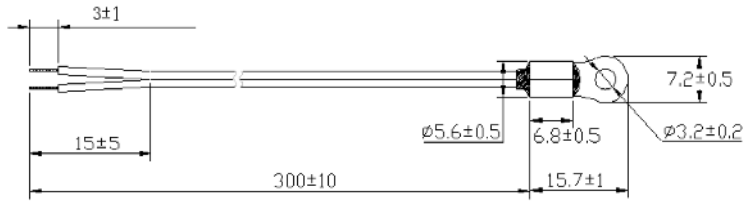

Lug type 3

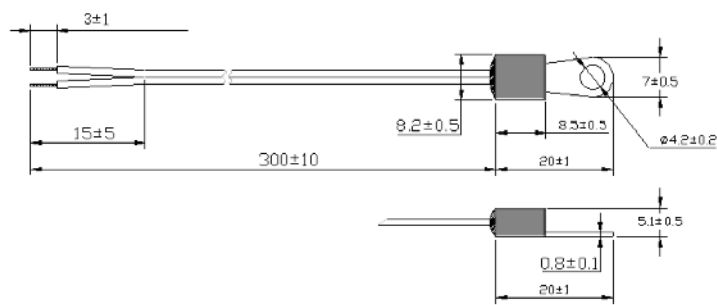

- 26AWG black Insulated lead wire with terminals tinned

Electrical specifications

Part number	Zero power resistance @ 25°C R ₂₅ (kΩ)	Ring lug type (Part number code)	R ₂₅ Tolerance (Part number code)	Beta type (Part number code)	Beta value (K)	Beta tolerance (Part number code)	Maximum power @ +25°C P _{max} (mW)	Dissipation factor (mW/°C)	Thermal time constant T (second)	Operation temperature TL~TU(°C)
NRGa103bxxxxBxc	1	(1), (2), (3)	±1% (F), ±3% (H)	25/85 (B2)	3435	±2% (G), ±3% (H)	50	≥ 2.5 (type3) ≥ 3.0 (others)	≤ 10 (type3) ≤ 9 (others)	-30 to +105
NRGa683bxxxxBxc	6.8	(1), (2), (3)	±1% (F), ±3% (H)	25/85 (B2)	3470	±2% (G), ±3% (H)	50	≥ 2.5 (type3) ≥ 3.0 (others)	≤ 10 (type3) ≤ 9 (others)	-30 to +105
NRGa683bxxxxBxc	6.8	(1), (2), (3)	±1% (F), ±3% (H)	25/85 (B2)	3975	±2% (G), ±3% (H)	50	≥ 2.5 (type3) ≥ 3.0 (others)	≤ 10 (type3) ≤ 9 (others)	-30 to +105
NRGa104bxxxxBxc	10	(1), (2), (3)	±1% (F), ±3% (H)	25/85 (B2)	3435	±1% (F), ±3% (H)	50	≥ 2.5 (type3) ≥ 3.0 (others)	≤ 10 (type3) ≤ 9 (others)	-30 to +105
NRGa104bxxxxBxc	10	(1), (2), (3)	±1% (F), ±3% (H)	25/85 (B2)	3975	±1% (F), ±3% (H)	50	≥ 2.5 (type3) ≥ 3.0 (others)	≤ 10 (type3) ≤ 9 (others)	-30 to +105
NRGa203bxxxxBxc	2	(1), (2), (3)	±1% (F), ±3% (H)	25/85 (B2)	3435	±1% (F), ±3% (H)	50	≥ 2.5 (type3) ≥ 3.0 (others)	≤ 10 (type3) ≤ 9 (others)	-30 to +105
NRGa224bxxxxBxc	22	(1), (2), (3)	±1% (F), ±3% (H)	25/85 (B2)	3740	±1% (F), ±3% (H)	50	≥ 2.5 (type3) ≥ 3.0 (others)	≤ 10 (type3) ≤ 9 (others)	-30 to +105
NRGa334bxxxxBxc	33	(1), (2), (3)	±1% (F), ±3% (H)	25/85 (B2)	3975	±1% (F), ±3% (H)	50	≥ 2.5 (type3) ≥ 3.0 (others)	≤ 10 (type3) ≤ 9 (others)	-30 to +105
NRGa474bxxxxBxc	47	(1), (2), (3)	±1% (F), ±3% (H)	25/85 (B2)	4090	±1% (F), ±3% (H)	50	≥ 2.5 (type3) ≥ 3.0 (others)	≤ 10 (type3) ≤ 9 (others)	-30 to +105
NRGa504bxxxxBxc	50	(1), (2), (3)	±1% (F), ±3% (H)	25/85 (B2)	3950	±1% (F), ±3% (H)	50	≥ 2.5 (type3) ≥ 3.0 (others)	≤ 10 (type3) ≤ 9 (others)	-30 to +105
NRGa504bxxxxBxc	50	(1), (2), (3)	±1% (F), ±3% (H)	25/85 (B2)	4050	±1% (F), ±3% (H)	50	≥ 2.5 (type3) ≥ 3.0 (others)	≤ 10 (type3) ≤ 9 (others)	-30 to +105
NRGa105bxxxxBxc	100	(1), (2), (3)	±1% (F), ±3% (H)	25/85 (B2)	4000	±1% (F), ±3% (H)	50	≥ 2.5 (type3) ≥ 3.0 (others)	≤ 10 (type3) ≤ 9 (others)	-30 to +105
NRGa105bxxxxBxc	100	(1), (2), (3)	±1% (F), ±3% (H)	25/85 (B2)	4190	±2% (G), ±3% (H)	50	≥ 2.5 (type3) ≥ 3.0 (others)	≤ 10 (type3) ≤ 9 (others)	-30 to +105
NRGa105bxxxxBxc	100	(1), (2), (3)	±1% (F), ±3% (H)	25/85 (B2)	4360	±2% (G), ±3% (H)	50	≥ 2.5 (type3) ≥ 3.0 (others)	≤ 10 (type3) ≤ 9 (others)	-30 to +105
NRGa475bxxxxBxc	470	(1), (2), (3)	±1% (F), ±3% (H)	25/85 (B2)	4570	±2% (G), ±3% (H)	50	≥ 2.5 (type3) ≥ 3.0 (others)	≤ 10 (type3) ≤ 9 (others)	-30 to +105
NRGa203bxxxxBxc	2	(1), (2), (3)	±1% (F), ±3% (H)	25/50 (B1)	3380	±2% (G), ±3% (H)	50	≥ 2.5 (type3) ≥ 3.0 (others)	≤ 10 (type3) ≤ 9 (others)	-30 to +105
NRGa503bxxxxBxc	5	(1), (2), (3)	±1% (F), ±3% (H)	25/50 (B1)	3420	±2% (G), ±3% (H)	50	≥ 2.5 (type3) ≥ 3.0 (others)	≤ 10 (type3) ≤ 9 (others)	-30 to +105
NRGa503bxxxxBxc	5	(1), (2), (3)	±1% (F), ±3% (H)	25/50 (B1)	3900	±2% (G), ±3% (H)	50	≥ 2.5 (type3) ≥ 3.0 (others)	≤ 10 (type3) ≤ 9 (others)	-30 to +105
NRGa104bxxxxBxc	10	(1), (2), (3)	±1% (F), ±3% (H)	25/50 (B1)	3380	±1% (F), ±3% (H)	50	≥ 2.5 (type3) ≥ 3.0 (others)	≤ 10 (type3) ≤ 9 (others)	-30 to +105
NRGa104bxxxxBxc	10	(1), (2), (3)	±1% (F), ±3% (H)	25/50 (B1)	4000	±1% (F), ±3% (H)	50	≥ 2.5 (type3) ≥ 3.0 (others)	≤ 10 (type3) ≤ 9 (others)	-30 to +105
NRGa104bxxxxBxc	10	(1), (2), (3)	±1% (F), ±3% (H)	25/50 (B1)	3950	±1% (F), ±3% (H)	50	≥ 2.5 (type3) ≥ 3.0 (others)	≤ 10 (type3) ≤ 9 (others)	-30 to +105
NRGa684bxxxxBxc	68	(1), (2), (3)	±1% (F), ±3% (H)	25/50 (B1)	3950	±1% (F), ±3% (H)	50	≥ 2.5 (type3) ≥ 3.0 (others)	≤ 10 (type3) ≤ 9 (others)	-30 to +105
NRGa224bxxxxBxc	22	(1), (2), (3)	±1% (F), ±3% (H)	25/50 (B1)	3700	±1% (F), ±3% (H)	50	≥ 2.5 (type3) ≥ 3.0 (others)	≤ 10 (type3) ≤ 9 (others)	-30 to +105
NRGa474bxxxxBxc	47	(1), (2), (3)	±1% (F), ±3% (H)	25/50 (B1)	3950	±1% (F), ±3% (H)	50	≥ 2.5 (type3) ≥ 3.0 (others)	≤ 10 (type3) ≤ 9 (others)	-30 to +105
NRGa474bxxxxBxc	47	(1), (2), (3)	±1% (F), ±3% (H)	25/50 (B1)	4020	±1% (F), ±3% (H)	50	≥ 2.5 (type3) ≥ 3.0 (others)	≤ 10 (type3) ≤ 9 (others)	-30 to +105
NRGa105bxxxxBxc	100	(1), (2), (3)	±1% (F), ±3% (H)	25/50 (B1)	3950	±1% (F), ±3% (H)	50	≥ 2.5 (type3) ≥ 3.0 (others)	≤ 10 (type3) ≤ 9 (others)	-30 to +105
NRGa105bxxxxBxc	100	(1), (2), (3)	±1% (F), ±3% (H)	25/50 (B1)	4120	±2% (G), ±3% (H)	50	≥ 2.5 (type3) ≥ 3.0 (others)	≤ 10 (type3) ≤ 9 (others)	-30 to +105
NRGa225bxxxxBxc	220	(1), (2), (3)	±1% (F), ±3% (H)	25/50 (B1)	4370	±2% (G), ±3% (H)	50	≥ 2.5 (type3) ≥ 3.0 (others)	≤ 10 (type3) ≤ 9 (others)	-30 to +105

a= Enter ring lug type from table above (1, 2, 3) See Mechanical parameters for lug type details

b= Enter resistance tolerance code from table above (F = ±1%, H = ±3%)

Bx= Enter Beta type code from table above (B1 = 25/50, B2 = 25/85)

c= Enter Beta tolerance code from table above (F = ±1%, G = ±2%, H = ±3%)

Temperature characteristics

Part number	NRG103 3435	NRG203 3435	NRG104 3435	NRG104 3975	NRG224 3740	NRG334 3975
B type	B25/85	B25/85	B25/85	B25/85	B25/85	B25/85
Temperature (°C)	Resistance (kΩ)	Resistance (kΩ)	Resistance (kΩ)	Resistance (kΩ)	Resistance (kΩ)	Resistance (kΩ)
-40	20.08	95	325	39.5	575	1116.42
-39	19.14	91.71	304.83	37.47	541.35	1045.23
-38	18.24	88.53	286.01	35.55	509.86	978.99
-37	17.38	85.46	268.45	33.74	480.37	917.34
-36	16.56	82.51	252.06	32.03	452.75	859.93
-35	15.78	79.66	236.76	30.41	426.86	806.46
-34	15.04	76.9	222.47	28.88	402.6	756.62
-33	14.33	74.25	209.11	27.43	379.85	710.15
-32	13.66	71.69	196.63	26.05	358.5	666.81
-31	13.01	69.22	184.95	24.76	338.48	626.37
-30	12.4	66.84	174.03	23.53	319.68	588.62
-29	11.82	64.54	163.82	22.36	302.02	553.36
-28	11.26	62.32	154.25	21.26	285.44	520.42
-27	10.73	60.18	145.3	20.22	269.86	489.64
-26	10.23	58.11	136.91	19.23	255.21	460.85
-25	9.75	56.12	129.05	18.3	241.44	433.93
-24	9.29	54.19	121.68	17.41	228.49	408.73
-23	8.85	52.34	114.78	16.57	216.3	385.14
-22	8.44	50.54	108.3	15.77	204.83	363.06
-21	8.04	48.81	102.22	15.02	194.03	342.36
-20	7.67	47.14	96.51	14.3	183.86	322.97
-19	7.31	45.53	91.15	13.62	174.28	304.79
-18	6.96	43.97	86.12	12.98	165.24	287.74
-17	6.64	42.47	81.4	12.37	156.73	271.74
-16	6.33	41.02	76.95	11.79	148.7	256.72
-15	6.03	39.62	72.78	11.24	141.13	242.62
-14	5.75	38.27	68.85	10.72	133.98	229.37
-13	5.49	36.96	65.16	10.22	127.23	216.93
-12	5.23	35.7	61.68	9.75	120.86	205.23
-11	4.99	34.49	58.41	9.31	114.85	194.23
-10	4.76	33.31	55.33	8.88	109.16	183.88
-9	4.54	32.18	52.42	8.48	103.79	174.15
-8	4.33	31.08	49.69	8.1	98.71	164.98
-7	4.13	30.03	47.11	7.73	93.91	156.35
-6	3.94	29	44.68	7.39	89.37	148.22
-5	3.76	28.02	42.39	7.06	85.07	140.56
-4	3.59	27.07	40.23	6.74	81	133.34
-3	3.42	26.15	38.19	6.45	77.15	126.54
-2	3.27	25.26	36.27	6.16	73.5	120.12
-1	3.12	24.4	34.45	5.89	70.05	114.06
0	2.98	23.57	32.73	5.64	66.78	108.34
1	2.85	22.77	31.11	5.39	63.67	102.94
2	2.72	22	29.58	5.16	60.73	97.84
3	2.6	21.26	28.13	4.94	57.94	93.02
4	2.48	20.54	26.76	4.73	55.29	88.47
5	2.37	19.84	25.46	4.53	52.78	84.17
6	2.27	19.17	24.23	4.34	50.4	80.1
7	2.17	18.52	23.07	4.16	48.14	76.25
8	2.07	17.89	21.97	3.98	45.99	72.6
9	1.98	17.29	20.93	3.82	43.94	69.15
10	1.89	16.71	19.95	3.66	42	65.89
11	1.81	16.14	19.01	3.51	40.16	62.8
12	1.73	15.6	18.13	3.37	38.41	59.87
13	1.66	15.07	17.29	3.23	36.74	57.09
14	1.59	14.56	16.49	3.1	35.16	54.46
15	1.52	14.07	15.74	2.98	33.65	51.96
16	1.46	13.6	15.02	2.86	32.21	49.59
17	1.4	13.14	14.34	2.74	30.85	47.35
18	1.34	12.7	13.7	2.64	29.54	45.21

Temperature characteristics, cont.

Part number	NRG103 3435	NRG203 3435	NRG104 3435	NRG104 3975	NRG224 3740	NRG334 3975
B type	B25/85	B25/85	B25/85	B25/85	B25/85	B25/85
Temperature (°C)	Resistance (kΩ)	Resistance (kΩ)	Resistance (kΩ)	Resistance (kΩ)	Resistance (kΩ)	Resistance (kΩ)
19	1.28	12.27	13.09	2.53	28.3	43.19
20	1.23	11.86	12.5	2.43	27.12	41.27
21	1.18	11.46	11.95	2.34	26	39.44
22	1.13	11.08	11.43	2.25	24.93	37.71
23	1.09	10.7	10.93	2.16	23.9	36.06
24	1.04	10.35	10.45	2.08	22.93	34.49
25	1	10	10	2	22	33
26	0.9603	9.67	9.57	1.92	21.11	31.58
27	0.9224	9.34	9.16	1.85	20.27	30.23
28	0.8862	9.03	8.77	1.78	19.46	28.95
29	0.8517	8.73	8.4	1.72	18.69	27.73
30	0.8188	8.44	8.05	1.65	17.95	26.56
31	0.7873	8.16	7.71	1.59	17.25	25.45
32	0.7573	7.89	7.39	1.54	16.57	24.4
33	0.7287	7.62	7.09	1.48	15.93	23.39
34	0.7013	7.37	6.8	1.43	15.32	22.43
35	0.6752	7.13	6.52	1.38	14.73	21.52
36	0.6502	6.89	6.25	1.33	14.17	20.64
37	0.6263	6.66	6	1.28	13.63	19.81
38	0.6035	6.44	5.76	1.23	13.12	19.02
39	0.5817	6.23	5.53	1.19	12.63	18.26
40	0.5608	6.03	5.31	1.15	12.15	17.54
41	0.5409	5.83	5.1	1.11	11.7	16.84
42	0.5218	5.64	4.9	1.07	11.27	16.18
43	0.5036	5.45	4.71	1.04	10.86	15.55
44	0.4861	5.27	4.53	1	10.46	14.95
45	0.4693	5.1	4.35	0.9668	10.08	14.37
46	0.4533	4.94	4.19	0.9345	9.72	13.82
47	0.438	4.78	4.03	0.9034	9.37	13.3
48	0.4233	4.62	3.87	0.8736	9.04	12.79
49	0.4092	4.47	3.73	0.8449	8.72	12.31
50	0.3957	4.33	3.59	0.8173	8.41	11.85
51	0.3827	4.19	3.45	0.7908	8.11	11.41
52	0.3703	4.05	3.33	0.7653	7.83	10.99
53	0.3584	3.92	3.2	0.7408	7.56	10.58
54	0.347	3.8	3.09	0.7173	7.3	10.19
55	0.336	3.67	2.97	0.6946	7.05	9.82
56	0.3255	3.56	2.87	0.6728	6.81	9.47
57	0.3154	3.44	2.76	0.6518	6.58	9.13
58	0.3057	3.34	2.66	0.6315	6.35	8.8
59	0.2963	3.23	2.57	0.6121	6.14	8.49
60	0.2874	3.13	2.48	0.5933	5.94	8.19
61	0.2788	3.03	2.39	0.5753	5.74	7.9
62	0.2705	2.93	2.31	0.5579	5.55	7.62
63	0.2625	2.84	2.23	0.5411	5.37	7.36
64	0.2549	2.75	2.15	0.525	5.19	7.1
65	0.2475	2.67	2.08	0.5094	5.02	6.86
66	0.2404	2.59	2	0.4944	4.86	6.62
67	0.2336	2.51	1.94	0.4799	4.7	6.4
68	0.227	2.43	1.87	0.4659	4.55	6.18
69	0.2207	2.35	1.81	0.4525	4.41	5.97
70	0.2146	2.28	1.75	0.4395	4.27	5.77
71	0.2087	2.21	1.69	0.4269	4.13	5.58
72	0.203	2.14	1.63	0.4148	4.01	5.39
73	0.1976	2.08	1.58	0.4031	3.88	5.21
74	0.1923	2.02	1.53	0.3919	3.76	5.04
75	0.1872	1.96	1.48	0.381	3.64	4.88
76	0.1823	1.9	1.43	0.3704	3.53	4.72
77	0.1776	1.84	1.38	0.3603	3.43	4.57

Temperature characteristics, cont.

Part number	NRG103 3435	NRG203 3435	NRG104 3435	NRG104 3975	NRG224 3740	NRG334 3975
B type	B25/85	B25/85	B25/85	B25/85	B25/85	B25/85
Temperature (°C)	Resistance (kΩ)	Resistance (kΩ)	Resistance (kΩ)	Resistance (kΩ)	Resistance (kΩ)	Resistance (kΩ)
78	0.173	1.79	1.34	0.3504	3.32	4.42
79	0.1686	1.73	1.3	0.3409	3.22	4.28
80	0.1643	1.68	1.26	0.3318	3.12	4.14
81	0.1602	1.63	1.22	0.3229	3.03	4.01
82	0.1562	1.59	1.18	0.3143	2.94	3.89
83	0.1524	1.54	1.14	0.306	2.85	3.77
84	0.1487	1.49	1.11	0.298	2.77	3.65
85	0.1451	1.45	1.07	0.2902	2.69	3.54
86	0.1416	1.41	1.04	0.2827	2.61	3.43
87	0.1383	1.37	1.01	0.2754	2.54	3.32
88	0.135	1.33	0.9764	0.2684	2.46	3.22
89	0.1319	1.29	0.947	0.2615	2.39	3.12
90	0.1288	1.26	0.9185	0.2549	2.32	3.03
91	0.1259	1.22	0.8911	0.2486	2.26	2.94
92	0.123	1.19	0.8647	0.2424	2.2	2.85
93	0.1202	1.15	0.8391	0.2364	2.13	2.77
94	0.1176	1.12	0.8145	0.2305	2.07	2.68
95	0.115	1.09	0.7907	0.2249	2.02	2.61
96	0.1124	1.06	0.7678	0.2194	1.96	2.53
97	0.11	1.03	0.7456	0.2141	1.91	2.46
98	0.1076	1	0.7242	0.209	1.86	2.39
99	0.1053	0.9775	0.7035	0.204	1.81	2.32
100	0.1031	0.9513	0.6835	0.1992	1.76	2.25
101	0.1009	0.926	0.6641	0.1945	1.71	2.19
102	0.0988	0.9014	0.6455	0.19	1.66	2.12
103	0.0968	0.8777	0.6274	0.1856	1.62	2.07
104	0.0948	0.8547	0.61	0.1813	1.58	2.01
105	0.0929	0.8324	0.5931	0.1771	1.54	1.95

Temperature characteristics

Part number	NRG105 4000	NRG105 4190	NRG105 4360	NRG203 3380	NRG104 3380	NRG104 4000
B type	B25/85	B25/85	B25/85	B25/50	B25/50	B25/50
Temperature (°C)	Resistance (kΩ)	Resistance (kΩ)	Resistance (kΩ)	Resistance (kΩ)	Resistance (kΩ)	Resistance (kΩ)
-40	3100	3300	3600	39.8	195	325
-39	2910.56	3098.57	3377.19	37.69	184.63	305.06
-38	2733.69	2910.37	3169.14	35.71	174.87	286.45
-37	2568.5	2734.47	2974.79	33.84	165.67	269.05
-36	2414.17	2570.02	2793.19	32.07	157.01	252.8
-35	2269.93	2416.23	2623.47	30.41	148.84	237.61
-34	2135.07	2272.35	2464.78	28.84	141.14	223.4
-33	2008.93	2137.7	2316.37	27.36	133.89	210.11
-32	1890.9	2011.65	2177.54	25.96	127.04	197.67
-31	1780.43	1893.63	2047.63	24.64	120.58	186.03
-30	1677	1783.07	1926.02	23.39	114.48	175.13
-29	1580.12	1679.48	1812.16	22.21	108.73	164.93
-28	1489.35	1582.39	1705.51	21.1	103.29	155.36
-27	1404.26	1491.36	1605.61	20.05	98.15	146.4
-26	1324.49	1405.99	1511.98	19.05	93.3	138
-25	1249.66	1325.9	1424.22	18.11	88.71	130.12
-24	1179.46	1250.74	1341.93	17.22	84.38	122.73
-23	1113.57	1180.2	1264.74	16.38	80.28	115.8
-22	1051.7	1113.95	1192.33	15.58	76.39	109.29
-21	993.6	1051.74	1124.38	14.83	72.72	103.18
-20	939.01	993.29	1060.59	14.11	69.25	97.44
-19	887.7	938.35	1000.7	13.44	65.96	92.04
-18	839.47	886.71	944.44	12.8	62.84	86.98
-17	794.11	838.15	891.6	12.19	59.88	82.21
-16	751.44	792.48	841.93	11.62	57.09	77.74
-15	711.28	749.5	795.25	11.07	54.43	73.52
-14	673.48	709.06	751.36	10.56	51.92	69.56
-13	637.88	670.98	710.08	10.07	49.53	65.83
-12	604.36	635.13	671.25	9.6	47.27	62.32
-11	572.77	601.36	634.7	9.16	45.12	59.01
-10	542.99	569.54	600.31	8.74	43.08	55.9
-9	514.92	539.56	567.93	8.35	41.15	52.96
-8	488.45	511.29	537.44	7.97	39.31	50.2
-7	463.47	484.63	508.71	7.61	37.56	47.59
-6	439.9	459.49	481.65	7.27	35.9	45.13
-5	417.65	435.77	456.14	6.95	34.33	42.81
-4	396.65	413.38	432.1	6.64	32.83	40.62
-3	376.81	392.25	409.42	6.35	31.4	38.56
-2	358.06	372.29	388.04	6.07	30.05	36.61
-1	340.35	353.45	367.87	5.81	28.76	34.77
0	323.6	335.65	348.83	5.56	27.53	33.03
1	307.76	318.82	330.86	5.32	26.36	31.38
2	292.78	302.92	313.9	5.09	25.25	29.83
3	278.61	287.88	297.88	4.88	24.19	28.36
4	265.2	273.67	282.74	4.67	23.18	26.97
5	252.5	260.22	268.45	4.48	22.22	25.66
6	240.48	247.49	254.93	4.29	21.3	24.42
7	229.09	235.44	242.16	4.11	20.43	23.24
8	218.3	224.04	230.09	3.94	19.59	22.13
9	208.07	213.25	218.66	3.78	18.8	21.07
10	198.37	203.02	207.86	3.63	18.04	20.07
11	189.18	193.33	197.64	3.48	17.32	19.13
12	180.46	184.15	187.96	3.34	16.63	18.23
13	172.19	175.45	178.81	3.21	15.97	17.38
14	164.33	167.2	170.13	3.08	15.34	16.57
15	156.88	159.38	161.92	2.96	14.73	15.81
16	149.81	151.96	154.14	2.84	14.16	15.08
17	143.08	144.92	146.77	2.73	13.61	14.4
18	136.7	138.24	139.78	2.62	13.09	13.74

Temperature characteristics, cont.

Part number	NRG105 4000	NRG105 4190	NRG105 4360	NRG203 3380	NRG104 3380	NRG104 4000
B type	B25/85	B25/85	B25/85	B25/50	B25/50	B25/50
Temperature (°C)	Resistance (kΩ)	Resistance (kΩ)	Resistance (kΩ)	Resistance (kΩ)	Resistance (kΩ)	Resistance (kΩ)
19	130.63	131.9	133.16	2.52	12.58	13.12
20	124.87	125.87	126.88	2.42	12.1	12.53
21	119.38	120.16	120.93	2.33	11.65	11.97
22	114.17	114.73	115.28	2.24	11.21	11.44
23	109.21	109.57	109.92	2.16	10.79	10.94
24	104.49	104.66	104.83	2.08	10.38	10.46
25	100	100	100	2	10	10
26	95.73	95.57	95.41	1.93	9.63	9.57
27	91.66	91.35	91.06	1.85	9.28	9.15
28	87.78	87.34	86.92	1.79	8.94	8.76
29	84.09	83.53	82.99	1.72	8.62	8.39
30	80.57	79.9	79.26	1.66	8.31	8.03
31	77.21	76.45	75.71	1.6	8.01	7.69
32	74.02	73.16	72.34	1.54	7.72	7.37
33	70.97	70.02	69.13	1.49	7.45	7.06
34	68.06	67.04	66.07	1.44	7.19	6.77
35	65.29	64.2	63.17	1.39	6.94	6.49
36	62.64	61.49	60.41	1.34	6.69	6.22
37	60.12	58.91	57.78	1.29	6.46	5.97
38	57.71	56.45	55.27	1.25	6.24	5.72
39	55.41	54.1	52.89	1.2	6.03	5.49
40	53.21	51.86	50.62	1.16	5.82	5.27
41	51.11	49.73	48.46	1.12	5.62	5.06
42	49.1	47.69	46.4	1.09	5.43	4.86
43	47.18	45.75	44.43	1.05	5.25	4.67
44	45.35	43.89	42.56	1.01	5.08	4.48
45	43.6	42.12	40.78	0.9809	4.91	4.31
46	41.92	40.43	39.08	0.9487	4.75	4.14
47	40.32	38.81	37.45	0.9178	4.59	3.98
48	38.78	37.27	35.91	0.8881	4.44	3.83
49	37.32	35.79	34.43	0.8595	4.3	3.68
50	35.91	34.38	33.02	0.832	4.16	3.54
51	34.57	33.04	31.68	0.8056	4.03	3.41
52	33.28	31.75	30.39	0.7801	3.9	3.28
53	32.05	30.52	29.16	0.7556	3.78	3.16
54	30.86	29.34	27.99	0.7321	3.66	3.04
55	29.73	28.21	26.87	0.7094	3.54	2.93
56	28.65	27.13	25.81	0.6875	3.43	2.82
57	27.61	26.1	24.78	0.6665	3.33	2.72
58	26.61	25.11	23.81	0.6462	3.22	2.62
59	25.65	24.17	22.87	0.6266	3.12	2.52
60	24.74	23.26	21.98	0.6078	3.03	2.43
61	23.86	22.39	21.13	0.5896	2.94	2.35
62	23.01	21.56	20.31	0.5721	2.85	2.26
63	22.2	20.76	19.53	0.5553	2.76	2.18
64	21.43	20	18.78	0.539	2.68	2.11
65	20.68	19.27	18.06	0.5233	2.6	2.03
66	19.96	18.57	17.38	0.5081	2.52	1.96
67	19.28	17.9	16.72	0.4935	2.45	1.89
68	18.61	17.25	16.1	0.4794	2.38	1.83
69	17.98	16.63	15.49	0.4658	2.31	1.77
70	17.37	16.04	14.92	0.4526	2.24	1.71
71	16.78	15.47	14.36	0.4399	2.18	1.65
72	16.22	14.92	13.84	0.4277	2.12	1.59
73	15.68	14.4	13.33	0.4158	2.06	1.54
74	15.16	13.89	12.84	0.4044	2	1.49
75	14.65	13.41	12.37	0.3933	1.94	1.44
76	14.17	12.94	11.93	0.3826	1.89	1.39
77	13.71	12.5	11.5	0.3722	1.84	1.35

Temperature characteristics, cont.

Part number	NRG105 4000	NRG105 4190	NRG105 4360	NRG203 3380	NRG104 3380	NRG104 4000
B type	B25/85	B25/85	B25/85	B25/50	B25/50	B25/50
Temperature (°C)	Resistance (kΩ)	Resistance (kΩ)	Resistance (kΩ)	Resistance (kΩ)	Resistance (kΩ)	Resistance (kΩ)
78	13.26	12.07	11.09	0.3622	1.79	1.3
79	12.83	11.66	10.69	0.3526	1.74	1.26
80	12.42	11.26	10.31	0.3432	1.69	1.22
81	12.02	10.88	9.95	0.3342	1.64	1.18
82	11.63	10.51	9.6	0.3254	1.6	1.14
83	11.26	10.16	9.26	0.3169	1.56	1.11
84	10.91	9.82	8.94	0.3087	1.51	1.07
85	10.57	9.5	8.63	0.3008	1.47	1.04
86	10.23	9.18	8.33	0.2931	1.44	1.01
87	9.92	8.88	8.05	0.2856	1.4	0.9746
88	9.61	8.59	7.77	0.2784	1.36	0.9445
89	9.31	8.31	7.51	0.2714	1.33	0.9156
90	9.03	8.04	7.25	0.2646	1.29	0.8877
91	8.75	7.78	7.01	0.2581	1.26	0.8608
92	8.48	7.53	6.78	0.2517	1.23	0.8349
93	8.23	7.29	6.55	0.2455	1.19	0.8098
94	7.98	7.06	6.33	0.2396	1.16	0.7857
95	7.74	6.84	6.12	0.2338	1.14	0.7624
96	7.51	6.62	5.92	0.2281	1.11	0.7399
97	7.29	6.42	5.73	0.2227	1.08	0.7182
98	7.07	6.22	5.54	0.2174	1.05	0.6972
99	6.87	6.02	5.36	0.2123	1.03	0.677
100	6.67	5.84	5.19	0.2073	1	0.6575
101	6.47	5.66	5.02	0.2024	0.977	0.6386
102	6.29	5.48	4.86	0.1977	0.9533	0.6204
103	6.1	5.32	4.71	0.1932	0.9303	0.6027
104	5.93	5.16	4.56	0.1887	0.9079	0.5857
105	5.76	5	4.42	0.1844	0.8863	0.5693

Temperature characteristics

Part number	NRG104 3950	NRG224 3700	NRG105 3950	NRG105 4120	NRG225 4370
B type	B25/50	B25/50	B25/50	B25/50	B25/50
Temperature (°C)	Resistance (kΩ)	Resistance (kΩ)	Resistance (kΩ)	Resistance (kΩ)	Resistance (kΩ)
-40	325	2056.32	3000	3250	8728.94
-39	304.83	1932.46	2819.84	3053.32	8171.87
-38	286.01	1816.68	2651.4	2869.42	7652.85
-37	268.46	1708.42	2493.87	2697.43	7169.11
-36	252.07	1607.15	2346.48	2536.52	6718.12
-35	236.77	1512.4	2208.54	2385.94	6297.51
-34	222.48	1423.7	2079.41	2244.97	5905.11
-33	209.12	1340.65	1958.46	2112.96	5538.92
-32	196.64	1262.86	1845.16	1989.31	5197.08
-31	184.96	1189.97	1738.98	1873.45	4877.85
-30	174.04	1121.66	1639.44	1764.86	4579.66
-29	163.83	1057.61	1546.09	1663.05	4301.03
-28	154.26	997.53	1458.53	1567.57	4040.59
-27	145.31	941.17	1376.36	1478	3797.08
-26	136.92	888.28	1299.23	1393.95	3569.34
-25	129.06	838.62	1226.81	1315.06	3356.26
-24	121.69	791.99	1158.78	1240.99	3156.86
-23	114.78	748.18	1094.87	1171.43	2970.19
-22	108.3	707.02	1034.8	1106.07	2795.39
-21	102.22	668.32	978.32	1044.66	2631.66
-20	96.52	631.94	925.21	986.93	2478.25
-19	91.16	597.72	875.25	932.66	2334.46
-18	86.13	565.53	828.23	881.61	2199.66
-17	81.4	535.23	783.97	833.58	2073.24
-16	76.96	506.7	742.3	788.39	1954.64
-15	72.78	479.84	703.05	745.85	1843.36
-14	68.86	454.53	666.07	705.8	1738.91
-13	65.16	430.69	631.22	668.08	1640.85
-12	61.69	408.22	598.37	632.55	1548.75
-11	58.41	387.03	567.39	599.06	1462.23
-10	55.33	367.05	538.17	567.5	1380.93
-9	52.43	348.19	510.59	537.75	1304.51
-8	49.69	330.41	484.57	509.69	1232.66
-7	47.12	313.62	460	483.22	1165.09
-6	44.69	297.76	436.81	458.24	1101.53
-5	42.4	282.79	414.89	434.67	1041.71
-4	40.23	268.64	394.19	412.42	985.41
-3	38.19	255.28	374.62	391.4	932.4
-2	36.27	242.64	356.11	371.56	882.49
-1	34.45	230.7	338.62	352.81	835.46
0	32.73	219.4	322.07	335.09	791.15
1	31.11	208.71	306.41	318.34	749.39
2	29.58	198.59	291.59	302.5	710.02
3	28.13	189.02	277.56	287.53	672.9
4	26.76	179.96	264.28	273.36	637.88
5	25.46	171.37	251.69	259.96	604.84
6	24.23	163.24	239.77	247.27	573.66
7	23.07	155.53	228.48	235.26	544.22
8	21.98	148.23	217.77	223.89	516.43
9	20.93	141.31	207.61	213.12	490.18
10	19.95	134.74	197.98	202.92	465.38
11	19.02	128.51	188.84	193.25	441.95
12	18.13	122.6	180.18	184.08	419.81
13	17.29	117	171.95	175.4	398.87
14	16.5	111.67	164.13	167.16	379.07
15	15.74	106.62	156.72	159.35	360.34
16	15.02	101.82	149.67	151.94	342.62
17	14.34	97.26	142.97	144.9	325.85
18	13.7	92.93	136.61	138.23	309.98

Temperature characteristics, cont.

Part number	NRG104 3950	NRG224 3700	NRG105 3950	NRG105 4120	NRG225 4370
B type	B25/50	B25/50	B25/50	B25/50	B25/50
Temperature (°C)	Resistance (kΩ)	Resistance (kΩ)	Resistance (kΩ)	Resistance (kΩ)	Resistance (kΩ)
19	13.09	88.81	130.56	131.89	294.95
20	12.5	84.89	124.81	125.87	280.72
21	11.95	81.17	119.35	120.16	267.24
22	11.43	77.63	114.14	114.73	254.46
23	10.93	74.26	109.19	109.57	242.36
24	10.45	71.05	104.48	104.66	230.88
25	10	68	100	100	220
26	9.57	65.09	95.73	95.57	209.68
27	9.16	62.33	91.66	91.35	199.89
28	8.77	59.69	87.79	87.34	190.6
29	8.4	57.18	84.1	83.52	181.79
30	8.05	54.79	80.58	79.89	173.42
31	7.71	52.51	77.23	76.44	165.48
32	7.39	50.33	74.03	73.14	157.93
33	7.09	48.26	70.98	70.01	150.77
34	6.8	46.28	68.08	67.02	143.96
35	6.52	44.4	65.3	64.18	137.49
36	6.25	42.6	62.65	61.47	131.34
37	6	40.88	60.13	58.88	125.49
38	5.76	39.24	57.71	56.42	119.93
39	5.53	37.67	55.41	54.07	114.64
40	5.31	36.17	53.21	51.83	109.61
41	5.1	34.74	51.1	49.69	104.82
42	4.9	33.38	49.09	47.65	100.26
43	4.71	32.07	47.17	45.71	95.92
44	4.53	30.82	45.34	43.85	91.79
45	4.35	29.63	43.58	42.08	87.85
46	4.19	28.49	41.9	40.38	84.1
47	4.03	27.4	40.3	38.77	80.53
48	3.87	26.35	38.76	37.22	77.13
49	3.73	25.36	37.29	35.74	73.88
50	3.59	24.4	35.88	34.33	70.79
51	3.45	23.48	34.53	32.98	67.84
52	3.33	22.61	33.24	31.69	65.03
53	3.2	21.77	32.01	30.46	62.34
54	3.09	20.96	30.82	29.28	59.78
55	2.97	20.19	29.69	28.15	57.33
56	2.87	19.45	28.6	27.07	55
57	2.76	18.75	27.56	26.04	52.77
58	2.66	18.07	26.56	25.05	50.65
59	2.57	17.42	25.6	24.1	48.61
60	2.48	16.79	24.68	23.2	46.67
61	2.39	16.19	23.8	22.33	44.82
62	2.31	15.62	22.96	21.5	43.04
63	2.23	15.07	22.15	20.7	41.35
64	2.15	14.54	21.37	19.94	39.73
65	2.08	14.03	20.62	19.21	38.18
66	2	13.54	19.9	18.5	36.7
67	1.94	13.08	19.21	17.83	35.28
68	1.87	12.63	18.55	17.19	33.92
69	1.81	12.19	17.91	16.57	32.62
70	1.75	11.78	17.3	15.97	31.38
71	1.69	11.38	16.71	15.4	30.19
72	1.63	11	16.15	14.86	29.05
73	1.58	10.63	15.61	14.33	27.96
74	1.53	10.27	15.09	13.83	26.91
75	1.48	9.93	14.58	13.34	25.91
76	1.43	9.6	14.1	12.88	24.95
77	1.38	9.29	13.64	12.43	24.03

Temperature characteristics, cont.

Part number	NRG104 3950	NRG224 3700	NRG105 3950	NRG105 4120	NRG225 4370
B type	B25/50	B25/50	B25/50	B25/50	B25/50
Temperature (°C)	Resistance (kΩ)	Resistance (kΩ)	Resistance (kΩ)	Resistance (kΩ)	Resistance (kΩ)
78	1.34	8.98	13.19	12	23.15
79	1.3	8.69	12.76	11.59	22.31
80	1.26	8.41	12.34	11.2	21.5
81	1.22	8.14	11.95	10.82	20.72
82	1.18	7.88	11.56	10.45	19.97
83	1.14	7.63	11.19	10.1	19.26
84	1.11	7.39	10.84	9.76	18.57
85	1.07	7.15	10.49	9.43	17.91
86	1.04	6.93	10.16	9.12	17.28
87	1.01	6.71	9.84	8.82	16.67
88	0.9762	6.5	9.54	8.53	16.09
89	0.9467	6.3	9.24	8.25	15.53
90	0.9183	6.11	8.95	7.98	14.99
91	0.8909	5.92	8.68	7.72	14.47
92	0.8644	5.74	8.41	7.48	13.97
93	0.8389	5.57	8.16	7.24	13.49
94	0.8143	5.4	7.91	7	13.04
95	0.7905	5.24	7.67	6.78	12.59
96	0.7675	5.08	7.44	6.57	12.17
97	0.7454	4.93	7.22	6.36	11.76
98	0.724	4.78	7	6.16	11.37
99	0.7033	4.64	6.8	5.97	10.99
100	0.6833	4.51	6.6	5.78	10.63
101	0.6639	4.37	6.4	5.61	10.28
102	0.6453	4.25	6.22	5.43	9.94
103	0.6272	4.13	6.04	5.27	9.61
104	0.6098	4.01	5.86	5.11	9.3
105	0.5929	3.89	5.69	4.95	9

Manual solder

+360 °C, 2.5 seconds maximum by soldering iron, distance between soldering position and coating 10 mm minimum.

Life Support Policy: Eaton does not authorize the use of any of its products for use in life support devices or systems without the express written approval of an officer of the Company. Life support systems are devices which support or sustain life, and whose failure to perform, when properly used in accordance with instructions for use provided in the labeling, can be reasonably expected to result in significant injury to the user.

Eaton reserves the right, without notice, to change design or construction of any products and to discontinue or limit distribution of any products. Eaton also reserves the right to change or update, without notice, any technical information contained in this bulletin.

Eaton
Electronics Division
1000 Eaton Boulevard
Cleveland, OH 44122
United States
Eaton.com/electronics

© 2022 Eaton
All Rights Reserved
Printed in USA
Publication No. ELX1225 BU-ELX22085
July 2022

Eaton is a registered trademark.

All other trademarks are property
of their respective owners.

Follow us on social media to get the
latest product and support information.

