

LOC		DIST		REVISIONS			
P	LTR	DESCRIPTION	DATE	DWN	APVD		
S		REVISED PER ECO-15-016062	10NOV15	KG	CD		

- THIS RCPT. IS DESIGNED TO CONFORM TO THE LATEST ISSUE OF MIL-C-24308.
 - MAX WIRE INSUL TO BE USED WITH THIS RCPT IS .068 DIA.
 - STAINLESS STEEL RETENTION CLIPS ARE INCLUDED IN INSERTS.
 - THIS RCPT. WILL ACCEPT SIZE 20 SOCKET CONTACT M39029/63-368 OR ANY TYCO HD-20 SOCKET CONTACT. CONTACTS ORDERED SEPARATELY.
- ⑤ TYCO PART NO. MARKED ON CONNECTOR REPRESENTS KIT NUMBER WITH CONTACTS.
 - ⑥ UL/CSA DESIGNATION STAMPED IN THIS AREA, OPTIONAL.
 - ⑦ RESTRICTED ITAR DRAWING.
 - ⑧ FINISH: CADMIUM PER QQ-P-416.
 - ⑨ FINISH: BRIGHT TIN PER ASTM-B-545 .000400-.000550 THK OVER COPPER PER AMS2418 .000050 MIN THK.

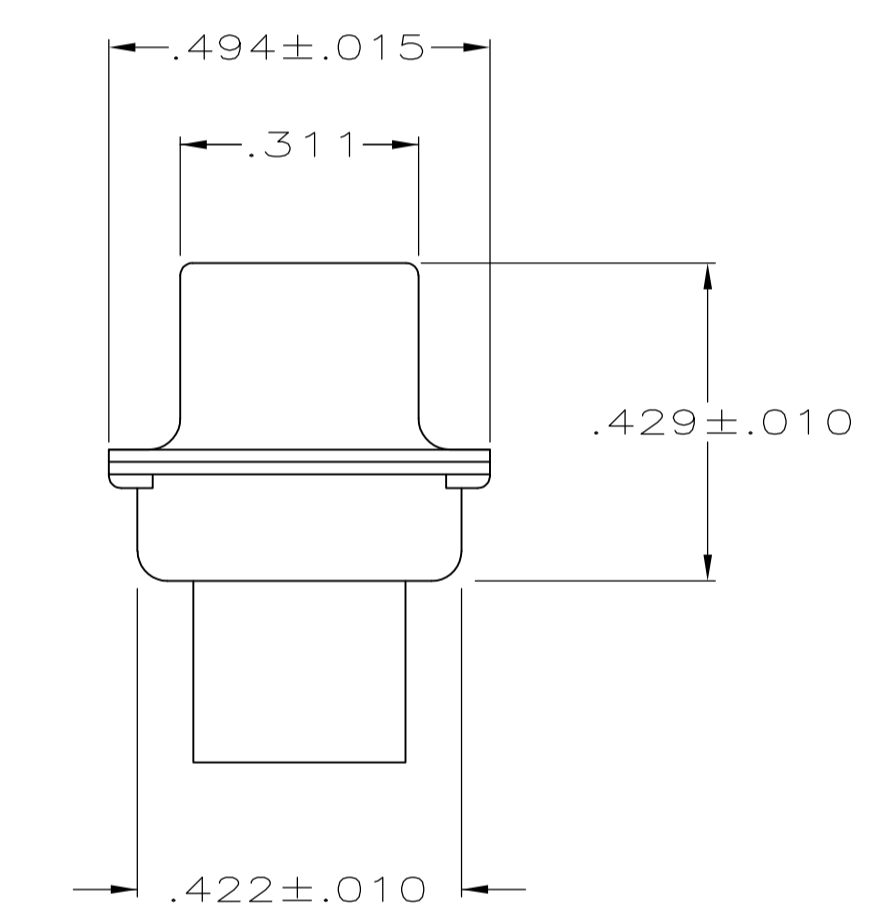
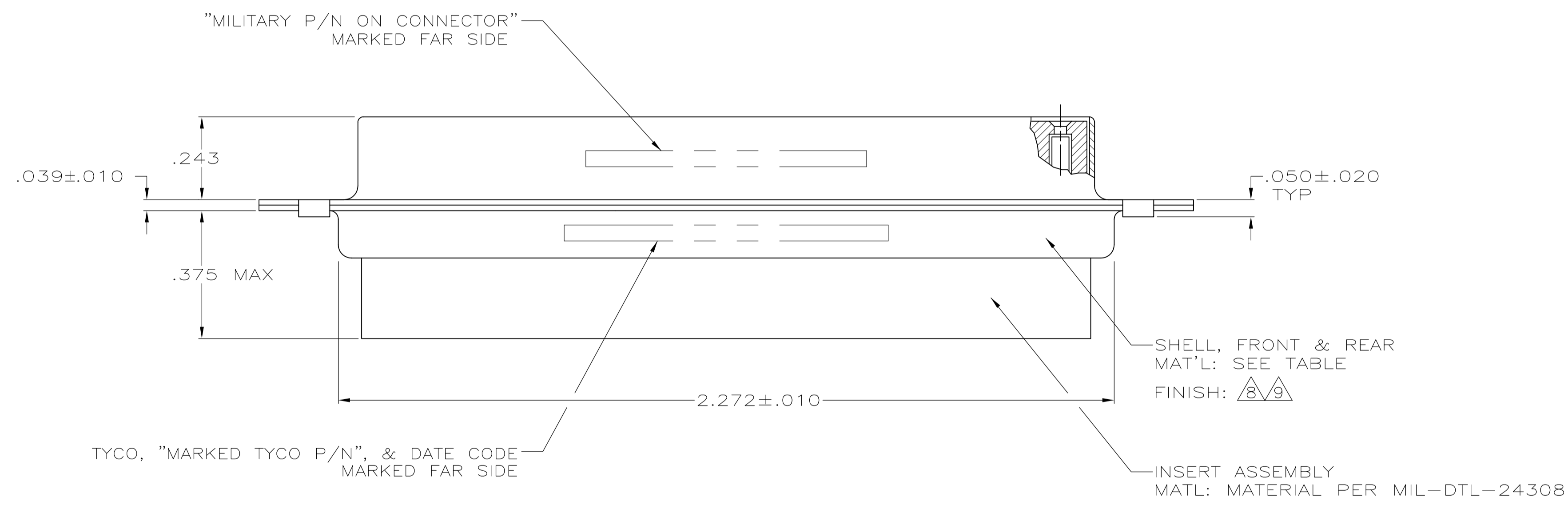
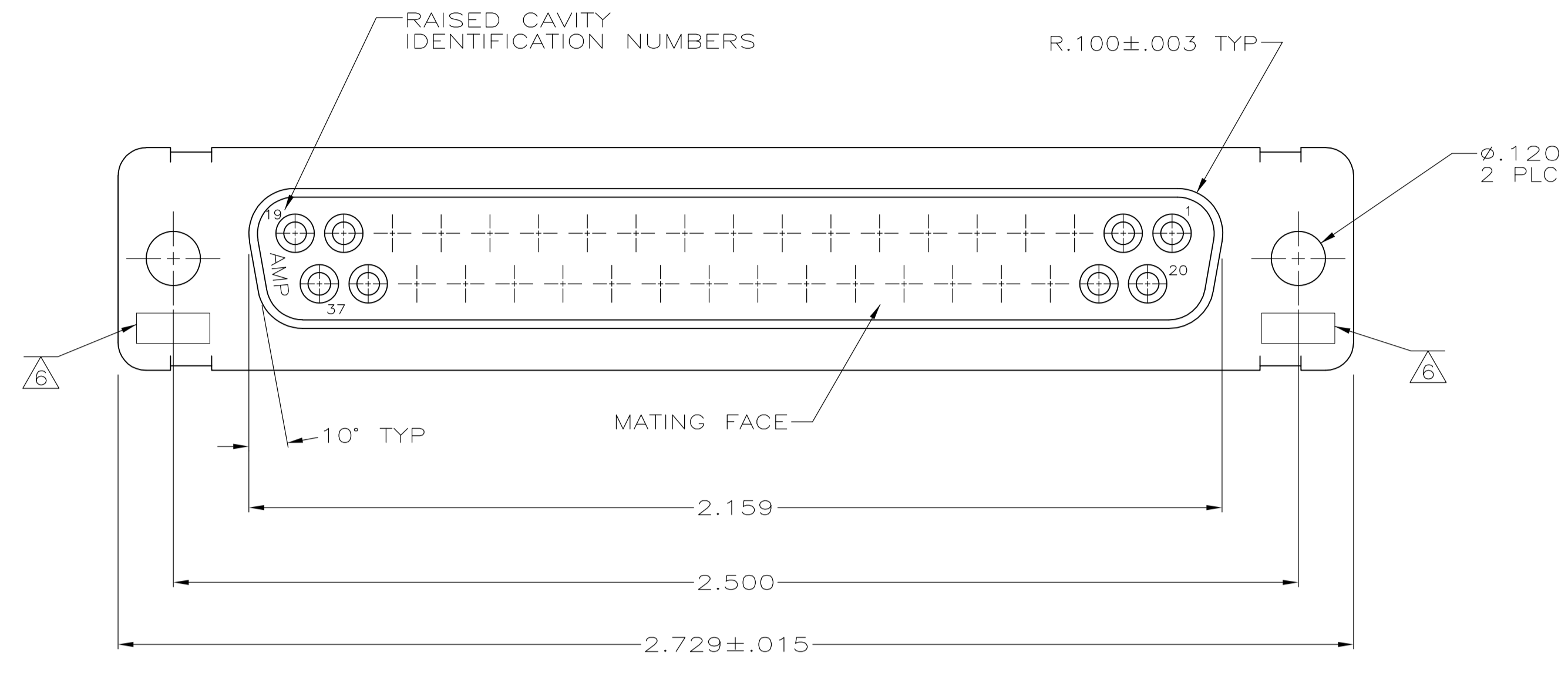

-	-	⑨	STEEL PER ASTM-A-109	-	205167-5	205167-5
-	⑦	-	-	-	-	205167-4
SUPSD BY 205291-1	-	⑧	STEEL PER ASTM-A-109	-	205167-3	205167-3
SUPSD BY 206803-2	-	-	BRASS	M24308/6-4F	205561-4	205167-2
M24308/2-284F	⑤	⑧	STEEL PER ASTM-A-109	M24308/2-4F	205561-2	205167-1
MILITARY P/N ON PACKAGE	REMARKS	SHELL FINISH	SHELL MAT'L	MARKED MILITARY PART NO.	MARKED TYCO PART NO.	PART NO.

THIS DRAWING IS A CONTROLLED DOCUMENT. **STE** TE Connectivity

MANJUNATH G. M. 27-May-15
 CHARLES THOMAS 27-May-15
 CHARLES THOMAS 31-JAN-03

RECEPTACLE ASSY
 AMPLIMITE, SIZE 4
 SERIES 109, HD-20

SIZE: A1 CAGE CODE: 00779 DRAWING NO: 205167
 WEIGHT: - RESTRICTED TO: -
 CUSTOMER DRAWING SCALE: 4:1 SHEET: 1 OF 1 REV: S