

**NRND – not Recommend for New Designs**

The MPC9653A is a 3.3 V compatible, 1:8 PLL based clock generator and zero-delay buffer targeted for high performance low-skew clock distribution in mid-range to high-performance telecom, networking and computing applications. With output frequencies up to 125 MHz and output skews less than 150 ps the device meets the needs of the most demanding clock applications.

#### Features

- 1:8 PLL based low-voltage clock generator
- Supports zero-delay operation
- 3.3 V power supply
- Generates clock signals up to 125 MHz
- PLL guaranteed to lock down to 145 MHz, output frequency = 36.25 MHz
- Maximum output skew of 150 ps
- Differential LVPECL reference clock input
- External PLL feedback
- Drives up to 16 clock lines
- 32-lead LQFP packaging
- 32-lead Pb-free Package Available
- Ambient temperature range 0°C to +70°C
- Pin and function compatible to the MPC953 and MPC9653
- **NRND – Not Recommend for New Designs**

The MPC9653A utilizes PLL technology to frequency lock its outputs onto an input reference clock. Normal operation of the MPC9653A requires the connection of the QFB output to the feedback input to close the PLL feedback path (external feedback). With the PLL locked, the output frequency is equal to the reference frequency of the device and VCO\_SEL selects the operating frequency range of 25 to 62.5 MHz or 50 to 125 MHz. The two available post-PLL dividers selected by VCO\_SEL (divide-by-4 or divide-by-8) and the reference clock frequency determine the VCO frequency. Both must be selected to match the VCO frequency range. The internal VCO of the MPC9653A is running at either 4x or 8x of the reference clock frequency. The MPC9653A is guaranteed to lock in a low power PLL mode in the high frequency range (VCO\_SEL = 0) down to PLL = 145 MHz or  $F_{ref} = 36.25$  MHz.

The MPC9653A has a differential LVPECL reference input along with an external feedback input. The device is ideal for use as a zero delay, low skew fanout buffer. The device performance has been tuned and optimized for zero delay performance.

The PLL\_EN and  $\overline{\text{BYPASS}}$  controls select the PLL bypass configuration for test and diagnosis. In this configuration, the selected input reference clock is bypassing the PLL and routed either to the output dividers or directly to the outputs. The PLL bypass configurations are fully static and the minimum clock frequency specification and all other PLL characteristics do not apply. The outputs can be disabled (high-impedance) and the device reset by asserting the MR/OE pin. Asserting MR/OE also causes the PLL to loose lock due to missing feedback signal presence at FB\_IN. Deasserting MR/OE will enable the outputs and close the phase locked loop, enabling the PLL to recover to normal operation.

The MPC9653A is fully 3.3 V compatible and requires no external loop filter components. The inputs (except PCLK) accept LVCMOS signals while the outputs provide LVCMOS compatible levels with the capability to drive terminated 50  $\Omega$  transmission lines. For series terminated transmission lines, each of the MPC9653A outputs can drive one or two traces giving the devices an effective fanout of 1:16. The device is packaged in a 7x7 mm<sup>2</sup> 32-lead LQFP package.

**MPC9653A**

**LOW VOLTAGE  
3.3 V LVCMOS 1:8  
PLL CLOCK GENERATOR**



**FA SUFFIX  
32-LEAD LQFP PACKAGE  
CASE 873A-03**



**AC SUFFIX  
32-LEAD LQFP PACKAGE  
Pb-FREE PACKAGE  
CASE 873A-03**

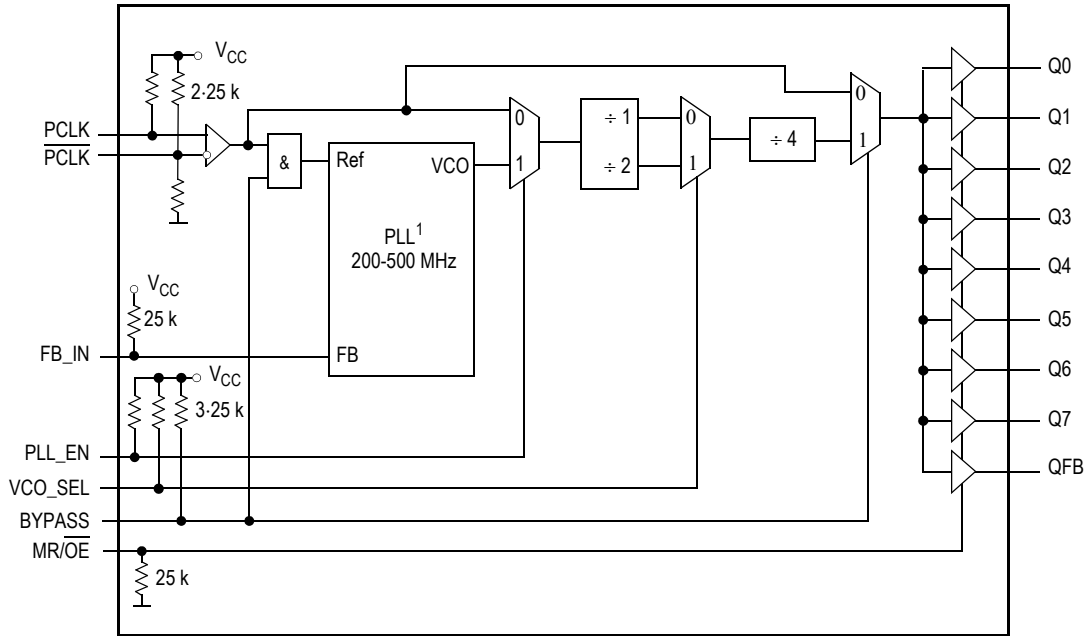

Note 1. PLL will lock @ 145 MHz

Figure 1. MPC9653A Logic Diagram

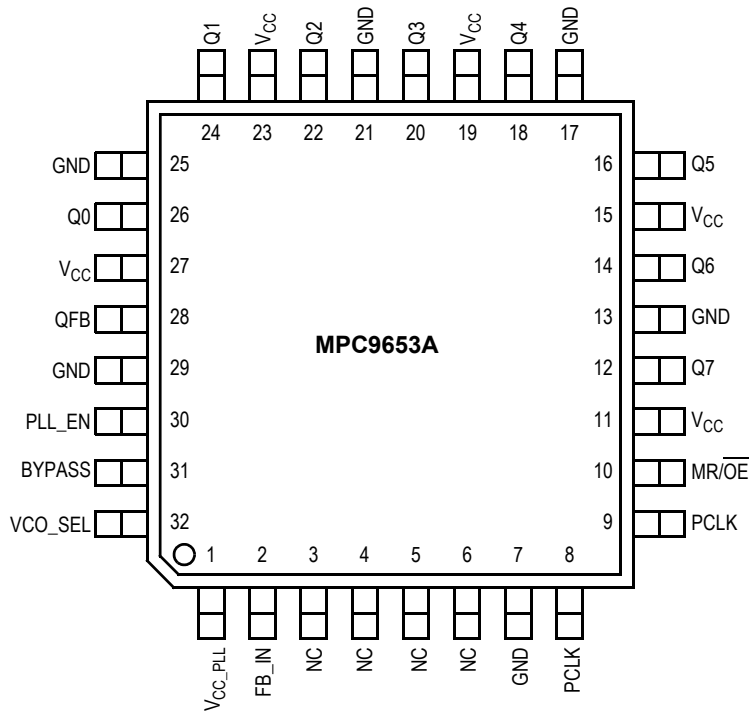

Figure 2. MPC9653A 32-Lead Package Pinout (Top View)

**Table 1. Pin Configuration**

Pin	I/O	Type	Function
PCLK, $\overline{\text{PCLK}}$	Input	LVPECL	PECL reference clock signal
FB_IN	Input	LVC MOS	PLL feedback signal input, connect to QFB
VCO_SEL	Input	LVC MOS	Operating frequency range select
$\overline{\text{BYPASS}}$	Input	LVC MOS	PLL and output divider bypass select
PLL_EN	Input	LVC MOS	PLL enable/disable
$\overline{\text{MR/OE}}$	Input	LVC MOS	Output enable/disable (high-impedance tristate) and device reset
Q0–7	Output	LVC MOS	Clock outputs
QFB	Output	LVC MOS	Clock output for PLL feedback, connect to FB_IN
GND	Supply	Ground	Negative power supply (GND)
V <sub>CC_PLL</sub>	Supply	V <sub>CC</sub>	PLL positive power supply (analog power supply). It is recommended to use an external RC filter for the analog power supply pin V <sub>CC_PLL</sub> . Refer to <a href="#">APPLICATIONS INFORMATION</a> for details.
V <sub>CC</sub>	Supply	V <sub>CC</sub>	Positive power supply for I/O and core. All V <sub>CC</sub> pins must be connected to the positive power supply for correct operation

**Table 2. Function Table**

Control	Default	0	1
PLL_EN	1	Test mode with PLL bypassed. The reference clock (PCLK) is substituted for the internal VCO output. MPC9653A is fully static and no minimum frequency limit applies. All PLL related AC characteristics are not applicable.	Selects the VCO output <sup>(1)</sup>
$\overline{\text{BYPASS}}$	1	Test mode with PLL and output dividers bypassed. The reference clock (PCLK) is directly routed to the outputs. MPC9653A is fully static and no minimum frequency limit applies. All PLL related AC characteristics are not applicable.	Selects the output dividers.
VCO_SEL	1	VCO ÷ 1 (High frequency range). $f_{\text{REF}} = f_{\text{Q0-7}} = 4 \cdot f_{\text{VCO}}$	VCO ÷ 2 (Low output range). $f_{\text{REF}} = f_{\text{Q0-7}} = 8 \cdot f_{\text{VCO}}$
$\overline{\text{MR/OE}}$	0	Outputs enabled (active)	Outputs disabled (high-impedance state) and reset of the device. During reset the PLL feedback loop is open. The VCO is tied to its lowest frequency. The length of the reset pulse should be greater than one reference clock cycle (PCLK).

1. PLL operation requires  $\overline{\text{BYPASS}} = 1$  and PLL\_EN = 1.

**Table 3. General Specifications**

Symbol	Characteristics	Min	Typ	Max	Unit	Condition
V <sub>TT</sub>	Output Termination Voltage		V <sub>CC</sub> ÷ 2		V	
MM	ESD Protection (Machine Model)	200			V	
HBM	ESD Protection (Human Body Model)	2000			V	
LU	Latch-Up Immunity	200			mA	
C <sub>PD</sub>	Power Dissipation Capacitance		10		pF	Per output
C <sub>IN</sub>	Input Capacitance		4.0		pF	Inputs

**Table 4. Absolute Maximum Ratings<sup>(1)</sup>**

Symbol	Characteristics	Min	Max	Unit	Condition
V <sub>CC</sub>	Supply Voltage	-0.3	3.9	V	
V <sub>IN</sub>	DC Input Voltage	-0.3	V <sub>CC</sub> + 0.3	V	
V <sub>OUT</sub>	DC Output Voltage	-0.3	V <sub>CC</sub> + 0.3	V	
I <sub>IN</sub>	DC Input Current		±20	mA	
I <sub>OUT</sub>	DC Output Current		±50	mA	
T <sub>S</sub>	Storage Temperature	-65	125	°C	

1. Absolute maximum continuous ratings are those maximum values beyond which damage to the device may occur. Exposure to these conditions or conditions beyond those indicated may adversely affect device reliability. Functional operation at absolute-maximum-rated conditions is not implied.

**Table 5. DC Characteristics (V<sub>CC</sub> = 3.3 V ± 5%, T<sub>A</sub> = 0°C to 70°C)**

Symbol	Characteristics	Min	Typ	Max	Unit	Condition
V <sub>IH</sub>	Input high voltage	2.0		V <sub>CC</sub> + 0.3	V	LVCMOS
V <sub>IL</sub>	Input low voltage			0.8	V	LVCMOS
V <sub>PP</sub>	Peak-to-peak input voltage (PCLK)	300			mV	LVPECL
V <sub>CMR</sub> <sup>(1)</sup>	Common Mode Range (PCLK)	1.0		V <sub>CC</sub> - 0.6	V	LVPECL
V <sub>OH</sub>	Output High Voltage	2.4			V	I <sub>OH</sub> = -24 mA <sup>(2)</sup>
V <sub>OL</sub>	Output Low Voltage			0.55 0.30	V V	I <sub>OL</sub> = 24 mA I <sub>OL</sub> = 12 mA
Z <sub>OUT</sub>	Output impedance		14 - 17		Ω	
I <sub>IN</sub>	Input Current <sup>(3)</sup>			±200	μA	V <sub>IN</sub> = V <sub>CC</sub> or GND
I <sub>CC_PLL</sub>	Maximum PLL Supply Current		5.0	10	mA	V <sub>CC_PLL</sub> Pin
I <sub>CCQ</sub> <sup>(4)</sup>	Maximum Quiescent Supply Current			10	mA	All V <sub>CC</sub> Pins

- V<sub>CMR</sub> (DC) is the crosspoint of the differential input signal. Functional operation is obtained when the crosspoint is within the V<sub>CMR</sub> range and the input swing lies within the V<sub>PP</sub> (DC) specification.
- The MPC9653A is capable of driving 50 Ω transmission lines on the incident edge. Each output drives one 50 Ω parallel terminated transmission line to a termination voltage of V<sub>TT</sub>. Alternatively, the device drives up to two 50 Ω series terminated transmission lines. The MPC9653A meets the V<sub>OH</sub> and V<sub>OL</sub> specification of the MPC953 (V<sub>OH</sub> > V<sub>CC</sub> - 0.6 V at I<sub>OH</sub> = -20 mA and V<sub>OL</sub> > 0.6 V at I<sub>OL</sub> = 20 mA).
- Inputs have pull-down or pull-up resistors affecting the input current.
- OE/MR = 1 (outputs in high-impedance state).

**Table 6. AC Characteristics** ( $V_{CC} = 3.3\text{ V} \pm 5\%$ ,  $T_A = 0^\circ\text{C}$  to  $70^\circ\text{C}$ )<sup>(1)</sup>

Symbol	Characteristics	Min	Typ	Max	Unit	Condition
$f_{REF}$	Input Reference Frequency $\div 4$ feedback <sup>(2)</sup>	50		125	MHz	PLL locked
	PLL Mode, External Feedback $\div 8$ feedback <sup>(3)</sup>	25		62.5	MHz	PLL locked
	Input reference frequency in PLL bypass mode <sup>(4)</sup>	0		200	MHz	
$f_{VCO}$	VCO Operating Frequency Range <sup>(5), (6)</sup>	200		500	MHz	
$f_{VCOlock}$	VCO Lock Frequency Range <sup>(7)</sup>	145		500	MHz	
$f_{MAX}$	Output Frequency	$\div 4$ feedback <sup>(2)</sup>	50	125	MHz	PLL locked
		$\div 8$ feedback <sup>(3)</sup>	25	62.5	MHz	PLL locked
$V_{PP}$	Peak-to-Peak Input Voltage PCLK	450		1000	mV	LVPECL
$V_{CMR}$ <sup>(8)</sup>	Common Mode Range PCLK	1.2		$V_{CC} - 0.75$	V	LVPECL
$t_{PW, MIN}$	Input Reference Pulse Width <sup>(9)</sup>	2			ns	
$t_{(\varnothing)}$	Propagation Delay (static phase offset) <sup>(10)</sup> PCLK to FB_IN	-75		125	ps	PLL locked
$t_{PD}$	Propagation Delay PLL and divider bypass ( $\overline{BYPASS} = 0$ ), PCLK to Q0-7 PLL disable ( $\overline{BYPASS} = 1$ and $PLL\_EN = 0$ ), PCLK to Q0-7		1.2	3.3	ns	
			3.0	7.0	ns	
$t_{sk(O)}$	Output-to-Output Skew <sup>(11)</sup>			150	ps	
$t_{sk(PP)}$	Device-to-Device Skew in PLL and Divider Bypass <sup>(12)</sup>			1.5	ns	$\overline{BYPASS} = 0$
DC	Output Duty Cycle	45	50	55	%	PLL locked
$t_R, t_F$	Output Rise/Fall Time	0.1		1.0	ns	0.55 to 2.4 V
$t_{PLZ, HZ}$	Output Disable Time			7.0	ns	
$t_{PZL, LZ}$	Output Enable Time			6.0	ns	
$t_{JIT(CC)}$	Cycle-to-Cycle jitter			100	ps	
$t_{JIT(PER)}$	Period Jitter			100	ps	
$t_{JIT(\varnothing)}$	I/O Phase Jitter <sup>(13)</sup> RMS ( $1\sigma$ )			25	ps	
BW	PLL closed loop bandwidth <sup>(14)</sup> PLL mode, external feedback	$\div 4$ feedback <sup>(2)</sup>		0.8 – 4	MHz	
		$\div 8$ feedback <sup>(3)</sup>		0.5 – 1.3	MHz	
$t_{LOCK}$	Maximum PLL Lock Time			10	ms	

- AC characteristics apply for parallel output termination of  $50\ \Omega$  to  $V_{TT}$ .
- $\div 4$  PLL feedback (high frequency range) requires  $VCO\_SEL = 0$ ,  $PLL\_EN = 1$ ,  $\overline{BYPASS} = 1$  and  $MR/\overline{OE} = 0$ .
- $\div 8$  PLL feedback (low frequency range) requires  $VCO\_SEL = 1$ ,  $PLL\_EN = 1$ ,  $\overline{BYPASS} = 1$  and  $MR/\overline{OE} = 0$ .
- In bypass mode, the MPC9653A divides the input reference clock.
- The input frequency  $f_{REF}$  must match the VCO frequency range divided by the feedback divider ratio FB:  $f_{REF} = f_{VCO} \div FB$ .
- $f_{VCO}$  is frequency range where AC parameters are guaranteed.
- $f_{VCOlock}$  is frequency range that the PLL guaranteed to lock, AC parameters only guaranteed over  $f_{VCO}$ .
- $V_{CMR}$  (AC) is the crosspoint of the differential input signal. Normal AC operation is obtained when the crosspoint is within the  $V_{CMR}$  range and the input swing lies within the  $V_{PP}$  (AC) specification. Violation of  $V_{CMR}$  or  $V_{PP}$  impacts static phase offset  $t_{(\varnothing)}$ .
- Calculation of reference duty cycle limits:  $DC_{REF, MIN} = t_{PW, MIN} \cdot f_{REF} \cdot 100\%$  and  $DC_{REF, MAX} = 100\% - DC_{REF, MIN}$ .  
For example, at  $f_{REF} = 100\text{ MHz}$  the input duty cycle range is  $20\% < DC < 80\%$ .
- Valid for  $f_{REF} = 50\text{ MHz}$  and  $FB = \div 8$  ( $VCO\_SEL = 1$ ). For other reference frequencies:  $t_{(\varnothing)} [\text{ps}] = 50\text{ ps} \pm (1 \div (120 \cdot f_{REF}))$ .
- Refer to the Application Information section for part-to-part skew calculation in PLL zero-delay mode.
- For a specified temperature and voltage, includes output skew.
- I/O phase jitter is reference frequency dependent. Refer to [APPLICATIONS INFORMATION](#) section for details.
- 3 dB point of PLL transfer characteristics.

APPLICATIONS INFORMATION

Programming the MPC9653A

The MPC9653A supports output clock frequencies from 25 to 125 MHz. Two different feedback divider configurations can be used to achieve the desired frequency operation range. The feedback divider (VCO\_SEL) should be used to situate the VCO in the frequency lock range between 200 and

500 MHz for stable and optimal operation. Two operating frequency ranges are supported: 25 to 62.5 MHz and 50 to 125 MHz. Table 7 illustrates the configurations supported by the MPC9653A. PLL zero-delay is supported if  $\overline{\text{BYPASS}} = 1$ ,  $\text{PLL\_EN} = 1$  and the input frequency is within the specified PLL reference frequency range.

Table 7. MPC9653A Configurations (QFB connected to FB\_IN)

$\overline{\text{BYPASS}}$	PLL_EN	VCO_SEL	Operation	Frequency		
				Ratio	Output Range ( $f_{Q0-7}$ )	VCO
0	X	X	Test mode: PLL and divider bypass	$f_{Q0-7} = f_{\text{REF}}$	0 – 200 MHz	n/a
1	0	0	Test mode: PLL bypass	$f_{Q0-7} = f_{\text{REF}} \div 4$	0 – 50 MHz	n/a
1	0	1	Test mode: PLL bypass	$f_{Q0-7} = f_{\text{REF}} \div 8$	0 – 25 MHz	n/a
1	1	0	PLL mode (high frequency range)	$f_{Q0-7} = f_{\text{REF}}$	50 to 125 MHz	$f_{\text{VCO}} = f_{\text{REF}} \cdot 4$
1	1	1	PLL mode (low frequency range)	$f_{Q0-7} = f_{\text{REF}}$	25 to 62.5 MHz	$f_{\text{VCO}} = f_{\text{REF}} \cdot 8$

Power Supply Filtering

The MPC9653A is a mixed analog/digital product. Its analog circuitry is naturally susceptible to random noise, especially if this noise is seen on the power supply pins. Random noise on the  $V_{\text{CCA\_PLL}}$  power supply impacts the device characteristics, for instance I/O jitter. The MPC9653A provides separate power supplies for the output buffers ( $V_{\text{CC}}$ ) and the phase-locked loop ( $V_{\text{CCA\_PLL}}$ ) of the device. The purpose of this design technique is to isolate the high switching noise digital outputs from the relatively sensitive internal analog phase-locked loop. In a digital system environment where it is more difficult to minimize noise on the power supplies a second level of isolation may be required. The simple but effective form of isolation is a power supply filter on the  $V_{\text{CC\_PLL}}$  pin for the MPC9653A. Figure 3 illustrates a typical power supply filter scheme. The MPC9653A frequency and phase stability is most susceptible to noise with spectral content in the 100 kHz to 20 MHz range. Therefore, the filter should be designed to target this range. The key parameter that needs to be met in the final filter design is the DC voltage drop across the series filter resistor  $R_F$ . From the data sheet the  $I_{\text{CCA}}$  current (the current sourced through the  $V_{\text{CC\_PLL}}$  pin) is typically 5 mA (10 mA maximum), assuming that a minimum of 2.985 V must be maintained on the  $V_{\text{CC\_PLL}}$  pin.

The minimum values for  $R_F$  and the filter capacitor  $C_F$  are defined by the required filter characteristics: the RC filter should provide an attenuation greater than 40 dB for noise whose spectral content is above 100 kHz. In the example RC filter shown in Figure 3, the filter cut-off frequency is around 4 kHz and the noise attenuation at 100 kHz is better than 42 dB.

As the noise frequency crosses the series resonant point of an individual capacitor its overall impedance begins to look inductive and thus increases with increasing frequency. The parallel capacitor combination shown ensures that a low impedance path to ground exists for frequencies well above the bandwidth of the PLL. Although the MPC9653A has several design features to minimize the susceptibility to power supply noise (isolated power and grounds and fully differential PLL) there still may be applications in which overall performance is being degraded due to system power supply noise. The power supply filter schemes discussed in this section should be adequate to eliminate power supply noise related problems in most designs.

Using the MPC9653A in Zero-Delay Applications

Nested clock trees are typical applications for the MPC9653A. Designs using the MPC9653A as LVCMOS PLL fanout buffer with zero insertion delay will show significantly lower clock skew than clock distributions developed from CMOS fanout buffers. The external feedback option of the MPC9653A clock driver allows for its use as a zero-delay buffer. The PLL aligns the feedback clock output edge with the clock input reference edge resulting a near zero delay through the device (the propagation delay through the device is virtually eliminated). The maximum insertion delay of the device in zero-delay applications is measured between the reference clock input and any output. This effective delay consists of the static phase offset, I/O jitter (phase or long-term jitter), feedback path delay and the output-to-output skew error relative to the feedback output.

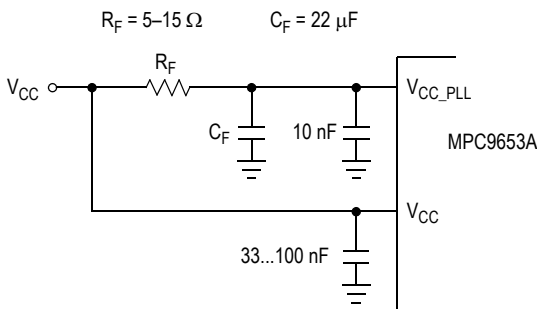

Figure 3.  $V_{\text{CC\_PLL}}$  Power Supply Filter

**Calculation of Part-to-Part Skew**

The MPC9653A zero delay buffer supports applications where critical clock signal timing can be maintained across several devices. If the reference clock inputs of two or more MPC9653As are connected together, the maximum overall timing uncertainty from the common PCLK input to any output is:

$$t_{SK(PP)} = t_{(\varnothing)} + t_{SK(O)} + t_{PD, LINE(FB)} + t_{JIT(\varnothing)} \cdot CF$$

This maximum timing uncertainty consist of 4 components: static phase offset, output skew, feedback board trace delay and I/O (phase) jitter:

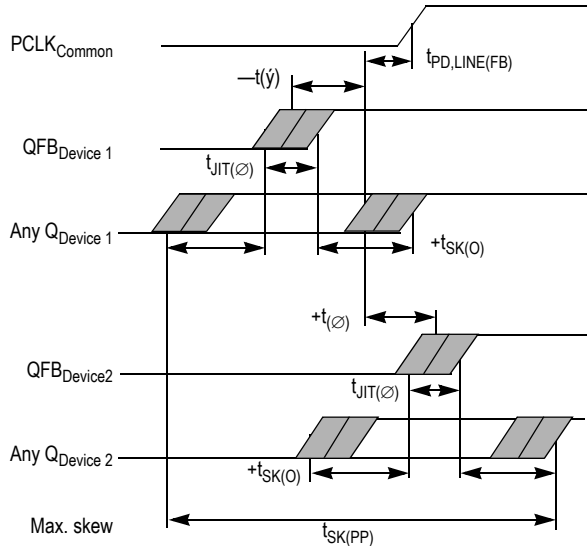

**Figure 4. MPC9653A Maximum Device-to-Device Skew**

Due to the statistical nature of I/O jitter a RMS value ( $1 \sigma$ ) is specified. I/O jitter numbers for other confidence factors (CF) can be derived from Table 8.

**Table 8. Confidence Factor CF**

CF	Probability of clock edge within the distribution
$\pm 1\sigma$	0.68268948
$\pm 2\sigma$	0.95449988
$\pm 3\sigma$	0.99730007
$\pm 4\sigma$	0.99993663
$\pm 5\sigma$	0.99999943
$\pm 6\sigma$	0.99999999

The feedback trace delay is determined by the board layout and can be used to fine-tune the effective delay through each device. In the following example calculation a I/O jitter confidence factor of 99.7% ( $\pm 3\sigma$ ) is assumed, resulting in a worst case timing uncertainty from input to any output of  $-197$  ps to  $297$  ps (at 125 MHz reference frequency) relative to PCLK:

$$t_{SK(PP)} = [-17ps...117ps] + [-150ps...150ps] + [(10ps @ -3)...(10ps @ 3)] + t_{PD, LINE(FB)}$$

$$t_{SK(PP)} = [-197ps...297ps] + t_{PD, LINE(FB)}$$

Due to the frequency dependence of the I/O jitter, Figure 5, can be used for a more precise timing performance analysis.

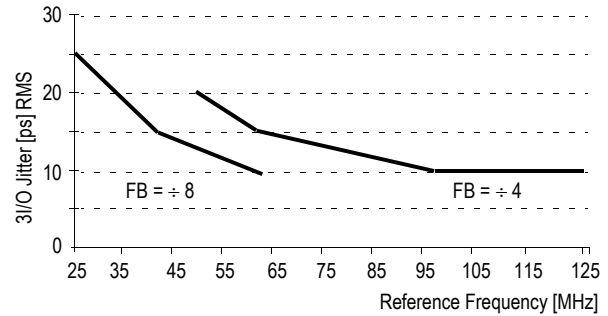

**Figure 5. Maximum I/O Jitter versus Frequency**

**Driving Transmission Lines**

The MPC9653A clock driver was designed to drive high speed signals in a terminated transmission line environment. To provide the optimum flexibility to the user the output drivers were designed to exhibit the lowest impedance possible. With an output impedance of less than  $20 \Omega$  the drivers can drive either parallel or series terminated transmission lines. For more information on transmission lines the reader is referred to Freescale Semiconductor application note AN1091. In most high performance clock networks point-to-point distribution of signals is the method of choice. In a point-to-point scheme either series terminated or parallel terminated transmission lines can be used. The parallel technique terminates the signal at the end of the line with a  $50 \Omega$  resistance to  $V_{CC} \div 2$ .

This technique draws a fairly high level of DC current and thus only a single terminated line can be driven by each output of the MPC9653A clock driver. For the series terminated case however there is no DC current draw, thus the outputs can drive multiple series terminated lines. Figure 5, illustrates an output driving a single series terminated line versus two series terminated lines in parallel. When taken to its extreme the fanout of the MPC9653A clock driver is effectively doubled due to its capability to drive multiple lines.



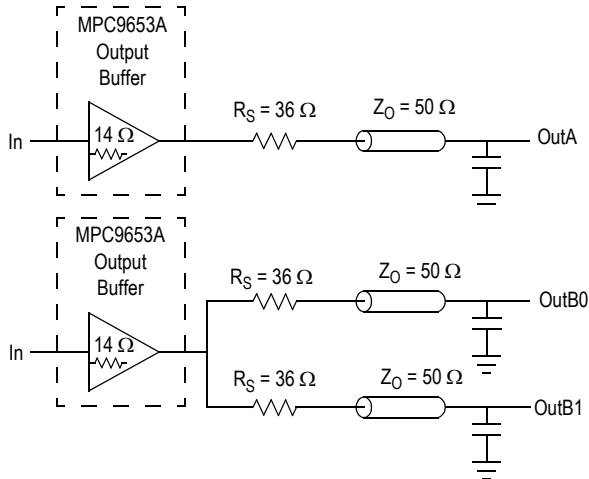

Figure 6. Single versus Dual Transmission Lines

The waveform plots in Figure 7 show the simulation results of an output driving a single line versus two lines. In both cases the drive capability of the MPC9653A output buffer is more than sufficient to drive 50 Ω transmission lines on the incident edge. Note from the delay measurements in the simulations a delta of only 43 ps exists between the two differently loaded outputs. This suggests that the dual line driving need not be used exclusively to maintain the tight output-to-output skew of the MPC9653A. The output waveform in Figure 7 shows a step in the waveform, this step is caused by the impedance mismatch seen looking into the driver. The parallel combination of the 36 Ω series resistor plus the output impedance does not match the parallel combination of the line impedances. The voltage wave launched down the two lines will equal:

$$V_L = V_S (Z_0 \div (R_S + R_0 + Z_0))$$

$$Z_0 = 50 \Omega \parallel 50 \Omega$$

$$R_S = 36 \Omega \parallel 36 \Omega$$

$$R_0 = 14 \Omega$$

$$V_L = 3.0 (25 \div (18 + 14 + 25))$$

$$= 1.31 \text{ V}$$

At the load end the voltage will double, due to the near unity reflection coefficient, to 2.6 V. It will then increment towards the quiescent 3.0 V in steps separated by one round trip delay (in this case 4.0 ns).

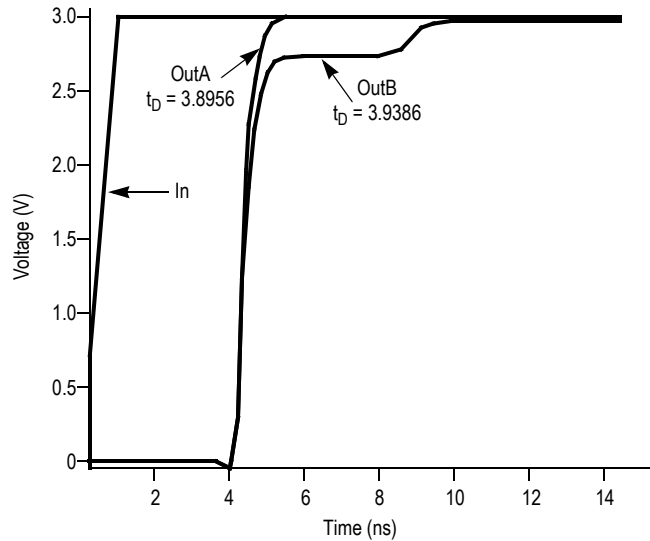

Figure 7. Single versus Dual Waveforms

Since this step is well above the threshold region it will not cause any false clock triggering, however designers may be uncomfortable with unwanted reflections on the line. To better match the impedances when driving multiple lines the situation in Figure 8, should be used. In this case the series terminating resistors are reduced such that when the parallel combination is added to the output buffer impedance the line impedance is perfectly matched.

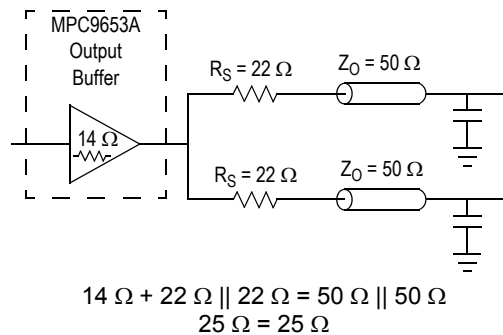

Figure 8. Optimized Dual Line Termination

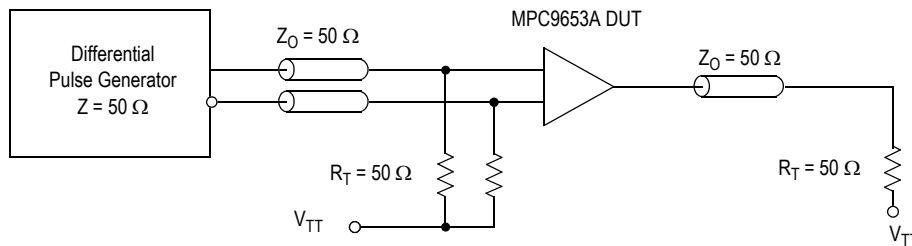
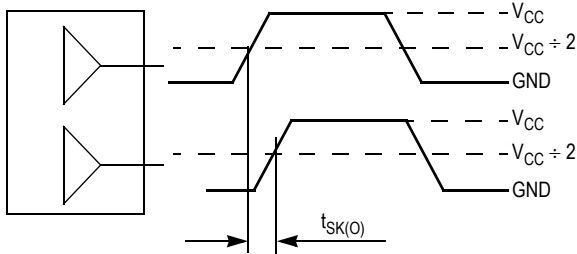

Figure 9. MPC9653A AC Test Reference





The pin-to-pin skew is defined as the worst case difference in propagation delay between any similar delay path within a single device

Figure 10. Output-to-Output Skew  $t_{SK(O)}$

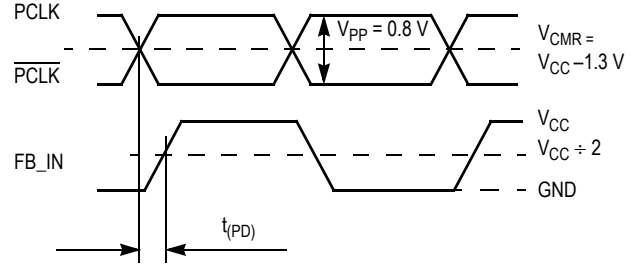
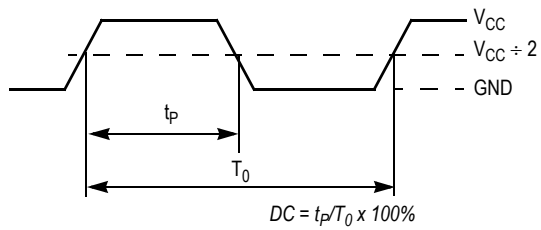
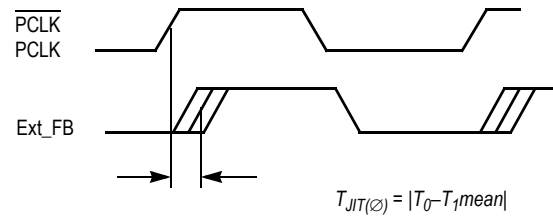

Figure 11. Propagation delay ( $t_{PD}$ ), static phase offset) Test Reference



The time from the PLL controlled edge to the non controlled edge, divided by the time between PLL controlled edges, expressed as a percentage

Figure 12. Output Duty Cycle (DC)



The deviation in  $t_0$  for a controlled edge with respect to a  $T_0$  mean in a random sample of cycles

Figure 13. I/O Jitter

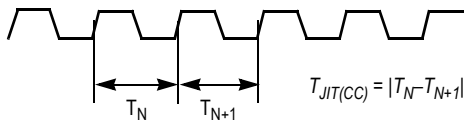

The variation in cycle time of a signal between adjacent cycles, over a random sample of adjacent cycle pairs

Figure 14. Cycle-to-Cycle Jitter

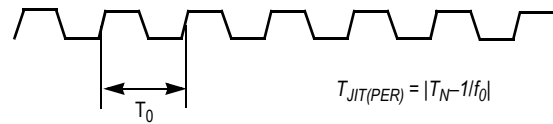

The deviation in cycle time of a signal with respect to the ideal period over a random sample of cycles

Figure 15. Period Jitter

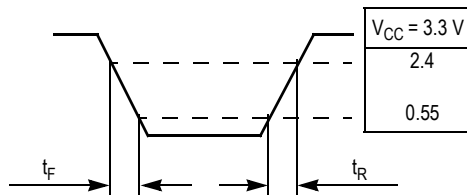
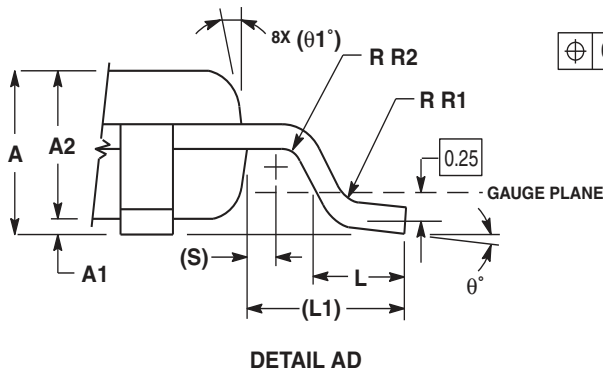
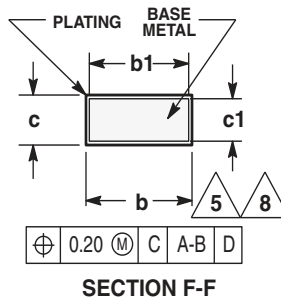
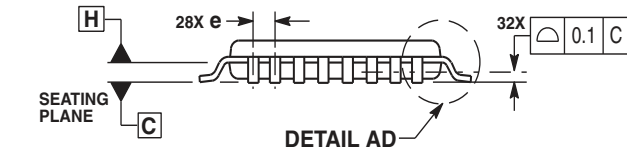
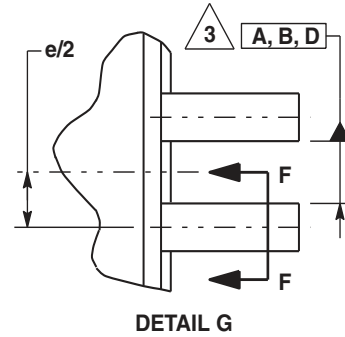
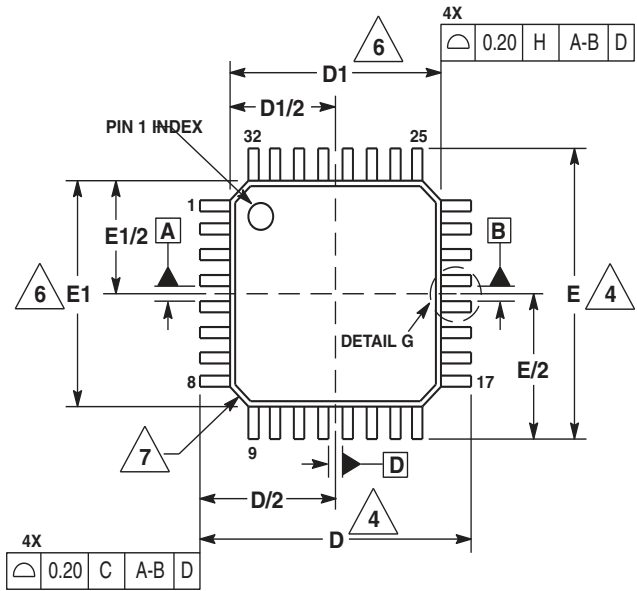

Figure 16. Output Transition Time Test Reference

PACKAGE DIMENSIONS



- NOTES:
1. DIMENSIONS ARE IN MILLIMETERS.
  2. INTERPRET DIMENSIONS AND TOLERANCES PER ASME Y14.5M, 1994.
  3. DATUMS A, B, AND D TO BE DETERMINED AT DATUM PLANE H.
  4. DIMENSIONS D AND E TO BE DETERMINED AT SEATING PLANE C.
  5. DIMENSION b DOES NOT INCLUDE DAMBAR PROTRUSION. ALLOWABLE DAMBAR PROTRUSION SHALL NOT CAUSE THE LEAD WIDTH TO EXCEED THE MAXIMUM b DIMENSION BY MORE THAN 0.08-mm. DAMBAR CANNOT BE LOCATED ON THE LOWER RADIUS OR THE FOOT. MINIMUM SPACE BETWEEN PROTRUSION AND ADJACENT LEAD OR PROTRUSION: 0.07-mm.
  6. DIMENSIONS D1 AND E1 DO NOT INCLUDE MOLD PROTRUSION. ALLOWABLE PROTRUSION IS 0.25-mm PER SIDE. D1 AND E1 ARE MAXIMUM PLASTIC BODY SIZE DIMENSIONS INCLUDING MOLD MISMATCH.
  7. EXACT SHAPE OF EACH CORNER IS OPTIONAL.
  8. THESE DIMENSIONS APPLY TO THE FLAT SECTION OF THE LEAD BETWEEN 0.1-mm AND 0.25-mm FROM THE LEAD TIP.

DIM	MILLIMETERS	
	MIN	MAX
A	1.40	1.60
A1	0.05	0.15
A2	1.35	1.45
b	0.30	0.45
b1	0.30	0.40
c	0.09	0.20
c1	0.09	0.16
D	9.00 BSC	
D1	7.00 BSC	
e	0.80 BSC	
E	9.00 BSC	
E1	7.00 BSC	
L	0.50	0.70
L1	1.00 REF	
q	0° - 7°	
q1	12 REF	
R1	0.08	0.20
R2	0.08	---
S	0.20 REF	

CASE 873A-03  
ISSUE B  
32-LEAD LQFP PACKAGE

## Revision History Sheet

Rev	Table	Page	Description of Change	Date
4		1	NRND – Not Recommend for New Designs	1/8/13



## IMPORTANT NOTICE AND DISCLAIMER

RENESAS ELECTRONICS CORPORATION AND ITS SUBSIDIARIES (“RENESAS”) PROVIDES TECHNICAL SPECIFICATIONS AND RELIABILITY DATA (INCLUDING DATASHEETS), DESIGN RESOURCES (INCLUDING REFERENCE DESIGNS), APPLICATION OR OTHER DESIGN ADVICE, WEB TOOLS, SAFETY INFORMATION, AND OTHER RESOURCES “AS IS” AND WITH ALL FAULTS, AND DISCLAIMS ALL WARRANTIES, EXPRESS OR IMPLIED, INCLUDING, WITHOUT LIMITATION, ANY IMPLIED WARRANTIES OF MERCHANTABILITY, FITNESS FOR A PARTICULAR PURPOSE, OR NON-INFRINGEMENT OF THIRD PARTY INTELLECTUAL PROPERTY RIGHTS.

These resources are intended for developers skilled in the art designing with Renesas products. You are solely responsible for (1) selecting the appropriate products for your application, (2) designing, validating, and testing your application, and (3) ensuring your application meets applicable standards, and any other safety, security, or other requirements. These resources are subject to change without notice. Renesas grants you permission to use these resources only for development of an application that uses Renesas products. Other reproduction or use of these resources is strictly prohibited. No license is granted to any other Renesas intellectual property or to any third party intellectual property. Renesas disclaims responsibility for, and you will fully indemnify Renesas and its representatives against, any claims, damages, costs, losses, or liabilities arising out of your use of these resources. Renesas' products are provided only subject to Renesas' Terms and Conditions of Sale or other applicable terms agreed to in writing. No use of any Renesas resources expands or otherwise alters any applicable warranties or warranty disclaimers for these products.

(Disclaimer Rev.1.0 Mar 2020)

### Corporate Headquarters

TOYOSU FORESIA, 3-2-24 Toyosu,  
Koto-ku, Tokyo 135-0061, Japan  
[www.renesas.com](http://www.renesas.com)

### Contact Information

For further information on a product, technology, the most up-to-date version of a document, or your nearest sales office, please visit:  
[www.renesas.com/contact/](http://www.renesas.com/contact/)

### Trademarks

Renesas and the Renesas logo are trademarks of Renesas Electronics Corporation. All trademarks and registered trademarks are the property of their respective owners.