

Evaluating the AD9467 16-Bit, 200 MSPS/250 MSPS ADC

FEATURES

Full featured evaluation board for the AD9467
SPI and alternate clock options
Internal and external reference options
VisualAnalog and SPI Controller software interfaces

EQUIPMENT NEEDED

Analog signal source and antialiasing filter
2 switching power supplies (6.0 V, 2.5 A) CUI EPS060250UH-
PHP-SZ, included
PC running Windows® 98 (2nd ed.), Windows 2000,
Windows ME, or Windows XP
USB 2.0 port, recommended (USB 1.1 compatible)
AD9467 evaluation board
HSC-ADC-EVALCZ FPGA-based data capture kit

DOCUMENTS NEEDED

AD9467 data sheet
HSC-ADC-EVALCZ data sheet, *High Speed Converter
Evaluation Platform* (FPGA-based data capture kit)
AN-905 Application Note, *VisualAnalog Converter Evaluation
Tool Version 1.0 User Manual*
AN-878 Application Note, *High Speed ADC SPI Control Software*
AN-877 Application Note, *Interface to High Speed ADCs via SPI*

SOFTWARE NEEDED

VisualAnalog
SPI Controller

GENERAL DESCRIPTION

This document describes the evaluation board for the AD9467, which provides all of the support circuitry required to operate the AD9467 in its various configurations. The application software used to interface with the device is also described.

The AD9467 data sheet, available at www.analog.com, which provides additional information, should be consulted when using the evaluation board. All documents and software tools are available at <http://www.analog.com/fifo>. For any questions, send an email to highspeed.converters@analog.com.

TYPICAL MEASUREMENT SETUP

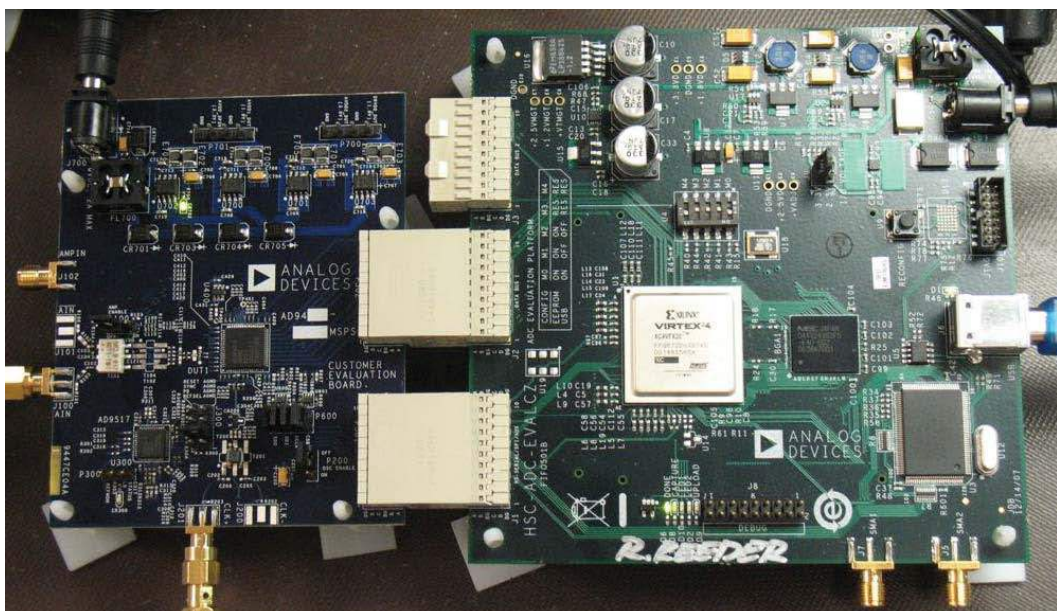

Figure 1. AD9467-250EBZ Evaluation Board and HSC-ADC-EVALCZ Data Capture Board

TABLE OF CONTENTS

Features	1	Input Signals.....	3
Equipment Needed.....	1	Output Signals	3
Documents Needed.....	1	Default Operation and Jumper Selection Settings.....	5
Software Needed.....	1	Evaluation Board Software Quick Start Procedures.....	6
General Description	1	Configuring the Board	6
Typical Measurement Setup	1	Using the Software for Testing.....	6
Revision History	2	Evaluation Board Schematics and Artwork.....	10
Evaluation Board Hardware.....	3	Ordering Information.....	25
Power Supplies	3	Bill of Materials.....	25

REVISION HISTORY

10/10—Revision 0: Initial Version

EVALUATION BOARD HARDWARE

The AD9467 evaluation board provides all of the support circuitry required to operate the AD9467 in its various modes and configurations. Figure 2 shows the typical bench characterization setup used to evaluate the performance of the AD9467. It is critical that the signal sources used for the analog input and clock have very low phase noise (<1 ps rms jitter) to realize the optimum performance of the signal chain. Proper filtering of the analog input signal to remove harmonics and lower the integrated or broadband noise at the input is necessary to achieve the specified noise performance (see the AD9467 data sheet).

See the Evaluation Board Software Quick Start Procedures section to get started and Figure 17 to Figure 31 for the complete schematics and layout diagrams that demonstrate the routing and grounding techniques that should be applied at the system level.

POWER SUPPLIES

This evaluation board comes with a wall-mountable switching power supply that provides a 6 V, 2.5 A maximum output. Connect the supply to the rated 100 V ac to 240 V ac wall outlet at 47 Hz to 63 Hz. The other end is a 2.1 mm inner diameter jack that connects to the PCB at P700. Once on the PC board, the 6 V supply is fused and conditioned before connecting to low dropout linear regulators that supply the proper bias to each of the various sections on the board.

When operating the evaluation board in a nondefault condition, E704, E705, E706, E707 can be removed to disconnect the switching power supply. This enables the user to bias each section of the board individually. Use P700 and P701 to connect a different supply for each section. At least one 1.8 V supply is needed with a 1 A current capability for 1.8 V AVDD1 and 1.8 V DRVDD;

however, it is recommended that separate supplies be used for both analog and digital domains. An additional supply is also required to supply 3.3 V to the DUT, 3.3 V AVDD2. This should also have a 1 A current capability. To operate the evaluation board using the SPI and alternate clock and amplifier options, a separate 3.3 V analog supply is needed in addition to the other supplies. The 3.3 V supply, or 3.3 V 3P3V_AVDD, should have a 1 A current capability.

INPUT SIGNALS

When connecting the ADC clock and analog source, use clean signal generators with low phase noise, such as Rohde & Schwarz SMA or HP8644B signal generators or the equivalent. Use a 1 m shielded, RG-58, 50 Ω coaxial cable for making connections to the evaluation board. Enter the desired frequency and amplitude (refer to the specifications in the AD9467 data sheet).

If a different or external ADC clock source is desired, follow the instructions in the Clock Circuitry section or use the on-board crystal oscillator, Y200. Typically, most Analog Devices, Inc., evaluation boards can accept ~ 2.8 V p-p or 13 dBm sine wave input for the clock. When connecting the analog input source, it is recommended to use a multipole, narrow-band band-pass filter with 50 Ω terminations. Analog Devices uses TTE and K&L Microwave, Inc., band-pass filters. The filter should be connected directly to the evaluation board.

OUTPUT SIGNALS

The default setup uses the FIFO5 high speed, dual-channel FIFO data capture board (HSC-ADC-EVALCZ). For more information on this board and its optional settings, visit <http://www.analog.com/fifo>.

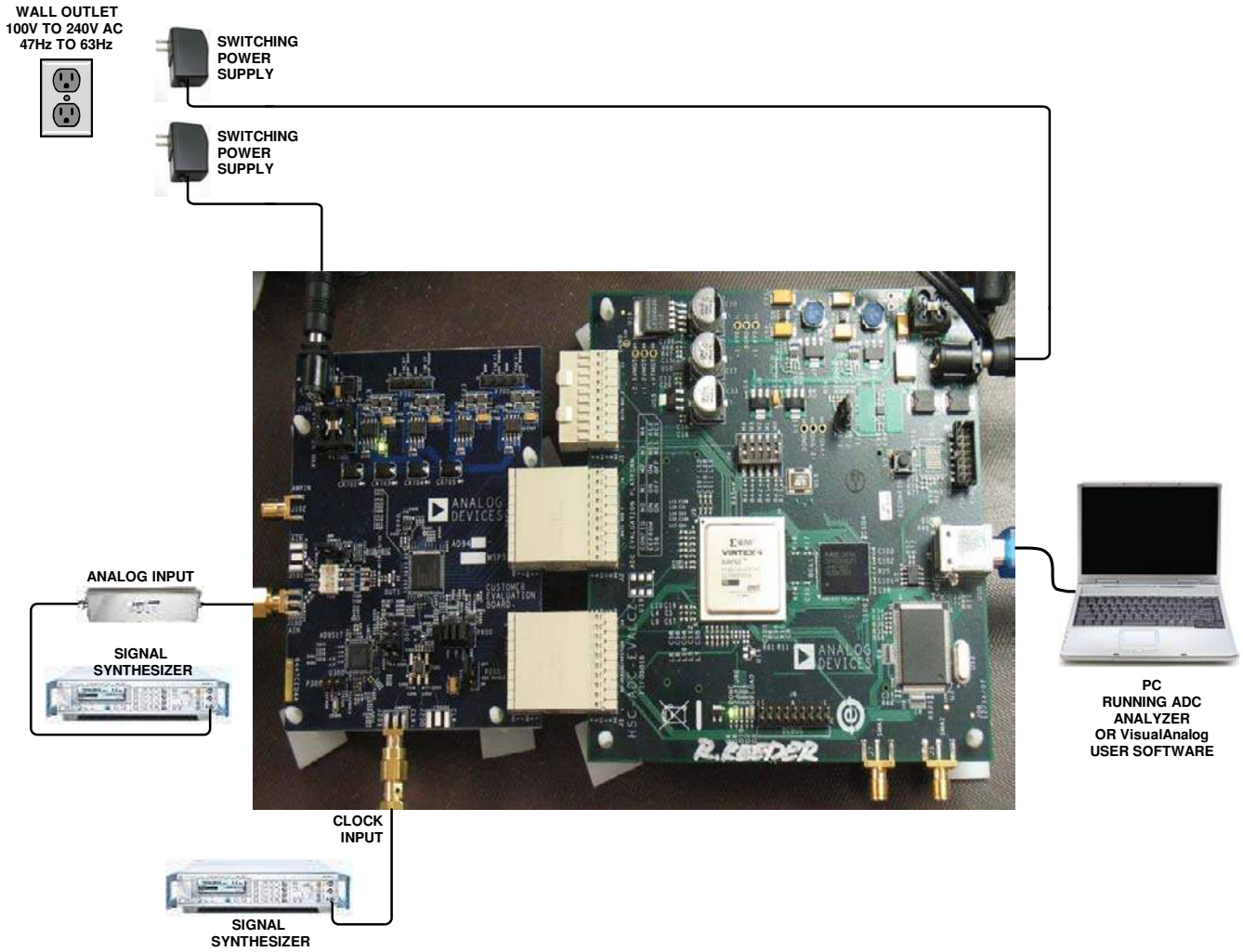

Figure 2. Evaluation Board Connection

09458-0102

DEFAULT OPERATION AND JUMPER SELECTION SETTINGS

This section explains the default and optional settings or modes allowed on the evaluation board for the AD9467.

Power Circuitry

Connect the switching power supply that is supplied in the evaluation kit between a rated 100 V ac to 240 V ac wall outlet at 47 Hz to 63 Hz and P700.

Analog Input Front-End Circuit

The evaluation board is set up for single-ended analog input connection with an optimum 50 Ω impedance match of 350 MHz of bandwidth. For a different bandwidth response, the input network needs to be changed or modified.

XVREF

XVREF is set to 1.25 V. This causes the ADC to operate with the default internal reference in the 2.5 V p-p full-scale range. A separate external reference option using the [ADR130](#) is also included on the evaluation board. Populate R400 with a 0 Ω resistor. Note that ADC full-scale ranges from 2.0 V p-p to 2.5 V p-p are supported by the AD9467.

Clock Circuitry

The default clock input circuitry is derived from a simple transformer-coupled circuit using a high bandwidth 1:1 impedance ratio transformer (T201) that adds a very low amount of jitter to the clock path. The clock input is 50 Ω terminated and ac-coupled to handle single-ended sine wave types of inputs. The transformer converts the single-ended input to a differential signal that is clipped before entering the ADC clock inputs.

The evaluation board can be set up to be clocked from the crystal oscillator, Y200. This oscillator is a low phase noise oscillator from Vectron (VCC6-QCD-250M000). If this clock source is desired, install C205 and C206 and remove C202. Jumper P200 is used to disable the oscillator from running.

A differential LVPECL or LVDS clock driver can also be used to clock the ADC input using the [AD9517](#) (U300). Populate C304, C305, C306, and C307 with 0.1 μ F capacitors for one drive option or the other and remove C209 and C210 to disconnect the default clock path inputs. The AD9517 has many SPI-selectable options that are set to a default mode of operation. Consult the AD9517 data sheet for more information about these and other options.

Dx+, Dx-

If an alternative data capture method to the setup shown in Figure 2 is used, optional receiver terminations, R500 to R509, can be installed next to the high speed backplane connector, P502.

EVALUATION BOARD SOFTWARE QUICK START PROCEDURES

This section provides quick start procedures for using the AD9467, either on the evaluation board or at the system level design. Both the default and optional settings are described.

CONFIGURING THE BOARD

Before using the software for testing, configure the evaluation board as follows:

1. Connect the evaluation board and the HSC-ADC-EVALCZ as shown in Figure 1 and Figure 2.
2. Connect one 6 V, 2.5 A switching power supply (such as the CUI, Inc., EPS060250UH-PHP-SZ included) to the evaluation board.
3. Connect one 6 V, 2.5 A switching power supply (such as the CUI EPS060250UH-PHP-SZ included) to the HSC-ADC-EVALCZ board.
4. Connect the USB cable to J6 on the HSC-ADC-EVALCZ board to the PC.
5. On the evaluation board, place jumpers on all four pin pairs of P600 to connect the SPI bus.
6. On the evaluation board, ensure that P200 is jumpered to the off setting to use the on-board 250 MHz Vectron VCC6 oscillator.
7. On the evaluation board, use a clean signal generator with low phase noise to provide an input signal to the desired channel. Use a 1 m, shielded, RG-58, 50 Ω coaxial cable to connect the signal generator. For best results, use a narrow-band band-pass filter with 50 Ω terminations and an appropriate center frequency. (Analog Devices uses TTE, Allen Avionics, and K&L band-pass filters.)

USING THE SOFTWARE FOR TESTING

Setting Up the ADC Data Capture

After configuring the evaluation board, set up the ADC data capture block using the following steps:

1. Open VisualAnalog® on a PC. AD9467 should be listed in the status bar of the **New Canvas** window. Select the template that corresponds to the type of testing to be performed (see Figure 3).

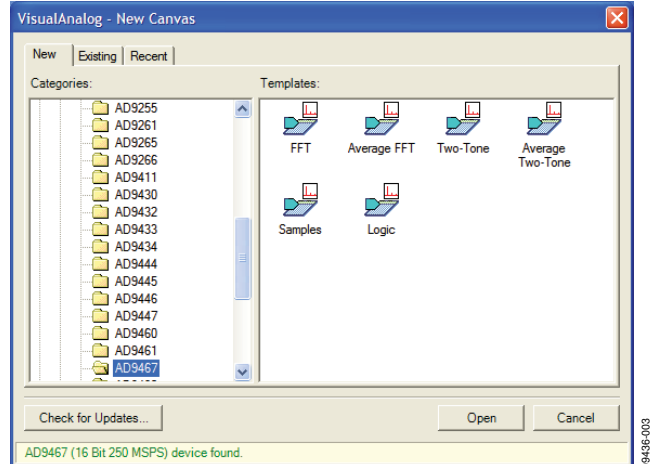

Figure 3. VisualAnalog, New Canvas Dialog Box

2. After the template is selected, a message box opens, asking if the default configuration can be used to program the FPGA (see Figure 4). Click **Yes**, and the window closes.

If a different program is desired, follow Step 3.

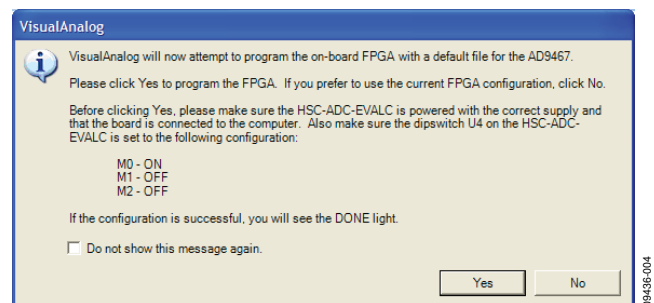

Figure 4. VisualAnalog, New Canvas Message Box

3. To view different channels or change features to settings other than the default settings, click the **Expand Display** button located on the top right corner of the VisualAnalog window, as shown in Figure 5 and Figure 6.

This process is described in the [AN-905](#) Application Note, *VisualAnalog Converter Evaluation Tool Version 1.0 User Manual*. Once you are finished, click the **Collapse Display** button.



Figure 5. VisualAnalog Window Toolbar, Expand Display Button

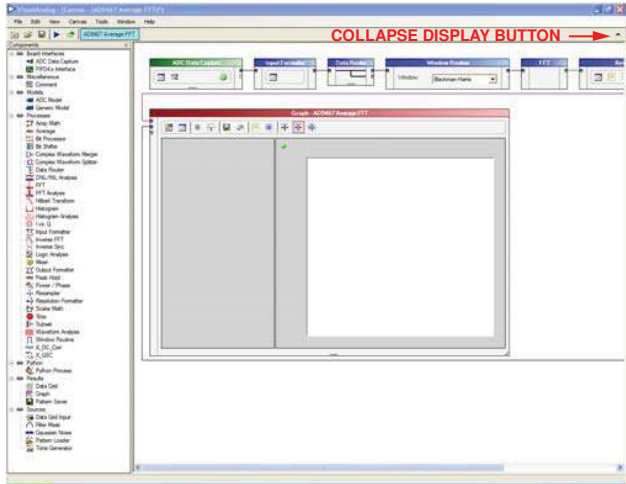

Figure 6. VisualAnalog, Main Window Expanded Display

4. Program the FPGA of the HSC-ADC-EVALCZ board to a setting other than the default setting as described in Step 3. Then expand the VisualAnalog display and click the **Settings** button in the **ADC Data Capture** block (see Figure 6). The **ADC Data Capture Settings** box opens (see Figure 7).

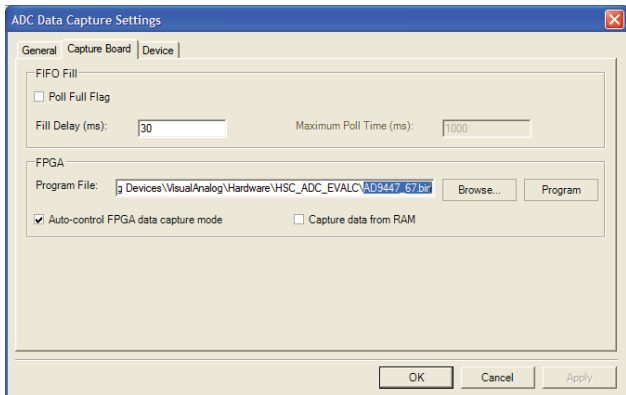

Figure 7. ADC Data Capture Settings, Capture Board Tab

5. Select the **Capture Board** tab and browse to the appropriate programming file. Next, click **Program**; the DONE LED, D6, in the HSC-ADC-EVALCZ board should then turn on.
6. Exit the **ADC Data Capture Settings** box by clicking **OK**.

Setting Up the SPI Controller

After the ADC data capture board setup has been completed, set up the SPI Controller:

1. Open the SPI Controller software by going to the **Start** menu or double-clicking the SPI Controller software desktop icon. If prompted for a configuration file, select the appropriate one. If not, check the title bar at the top of the SPI Controller window to determine which configuration is loaded. If necessary, choose **Cfg Open** from the **File**

menu and select the appropriate configuration. Note that the **CHIP ID(1)** field should be filled to indicate whether the correct SPI Controller configuration file is loaded (see Figure 8).

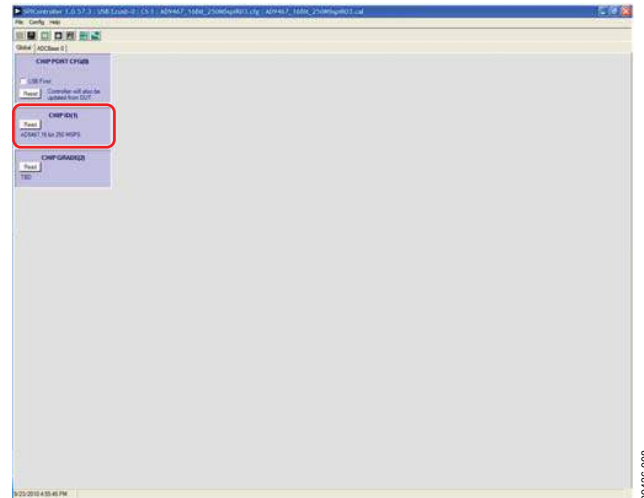

Figure 8. SPI Controller, CHIP ID(1) Box

2. Click the **New DUT** button in the SPI Controller (see Figure 9).

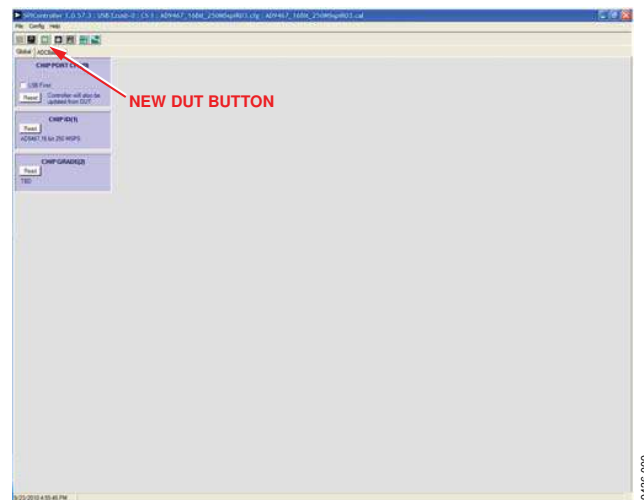

Figure 9. SPI Controller, New DUT Button

3. Click the **Run** button in the VisualAnalog toolbar (see Figure 10).

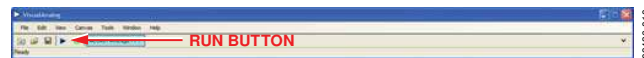

Figure 10. VisualAnalog Window Toolbar, Run Button

Applying Input Signal and Optimizing SFDR

Apply the input signal as follows:

1. Apply the input signal so that the fundamental is at the desired level (examine the **Fund Power** reading in the left panel of the **VisualAnalog FFT** window). See Figure 11 and Figure 12.

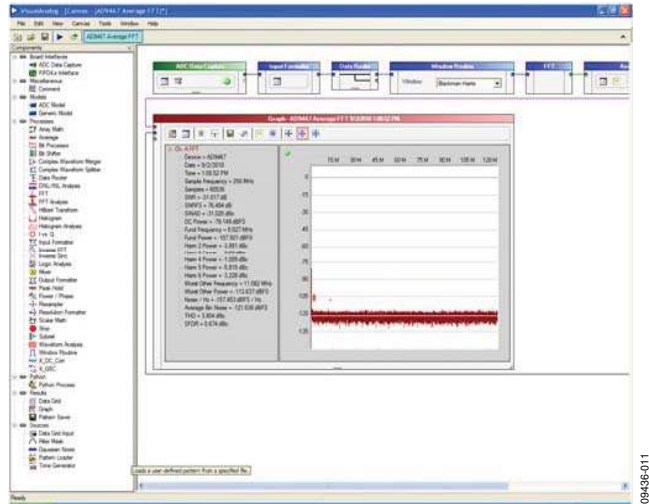

Figure 11. VisualAnalog, FFT Graph, No Signal or Very Low Signal Applied

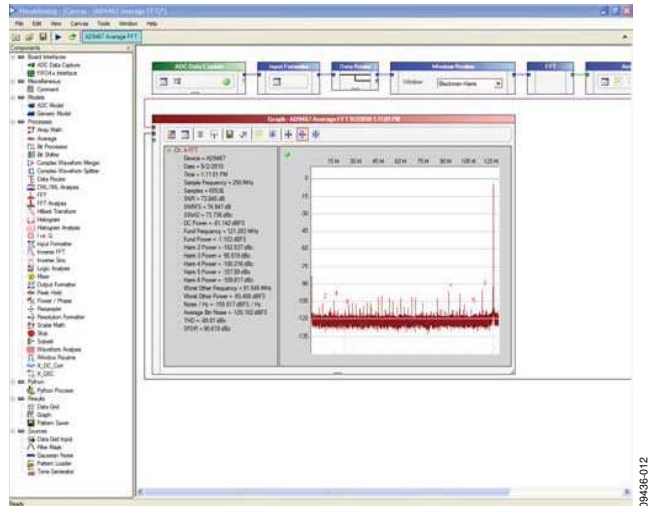

Figure 12. VisualAnalog, FFT Graph, Full-Scale Signal Applied

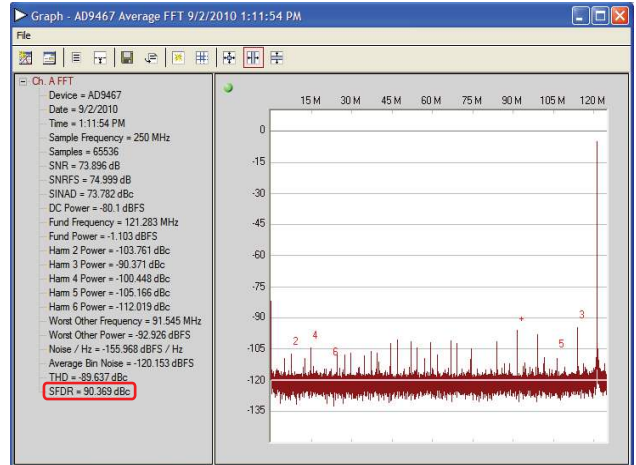

Figure 13. Typical FFT, AD9467 (No Buffer Current Optimization)

2. To optimize SFDR performance, use Register 36 and Register 107 to change the buffer current setting. In the **ADCBASE 0** tab of the SPI Controller, find the **BUFFER(36)/BUFFER(107)** box. Use the drop-down list box to select the best current, if necessary. See the AD9467 data sheet, the [AN-878](#) Application Note, and the [AN-877](#) Application Note for reference.

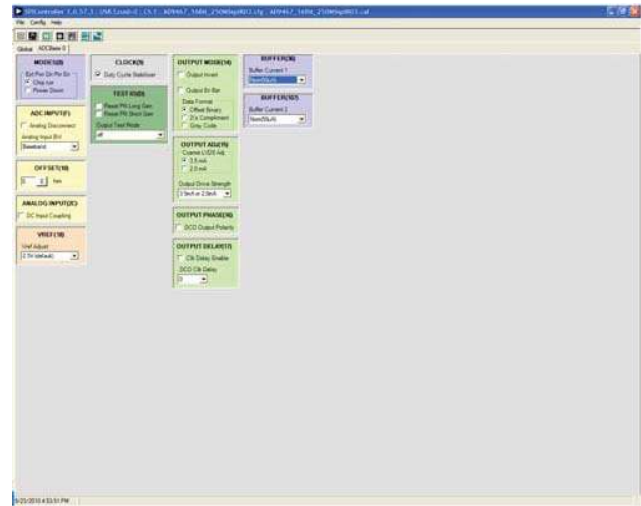

Figure 14. SPI Controller, BUFFER(36)/BUFFER(107)

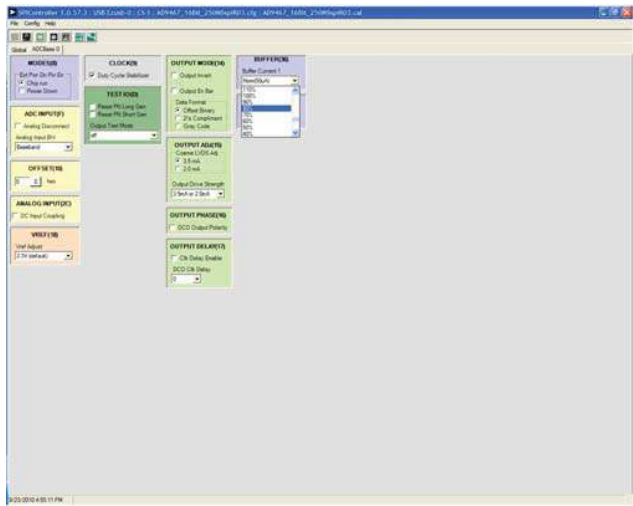

Figure 15. SPI Controller, SPI Controller, BUFFER(36)/BUFFER(107) Drop-Down Setting

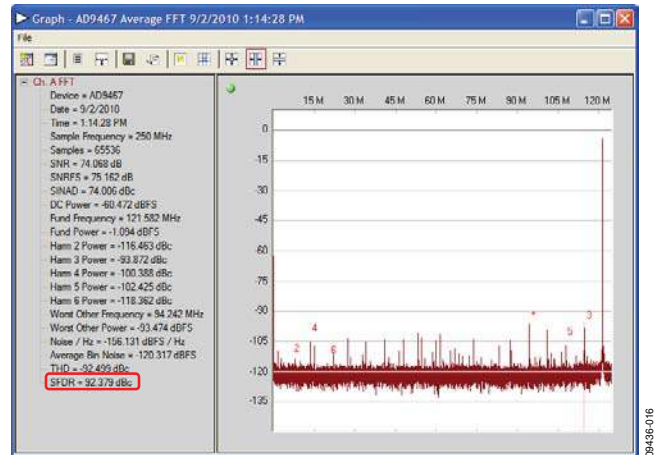

Figure 16. Typical FFT, AD9467 (With Buffer Current Optimized)

EVALUATION BOARD SCHEMATICS AND ARTWORK

09436-017

ANALOG INPUT CIRCUITRY

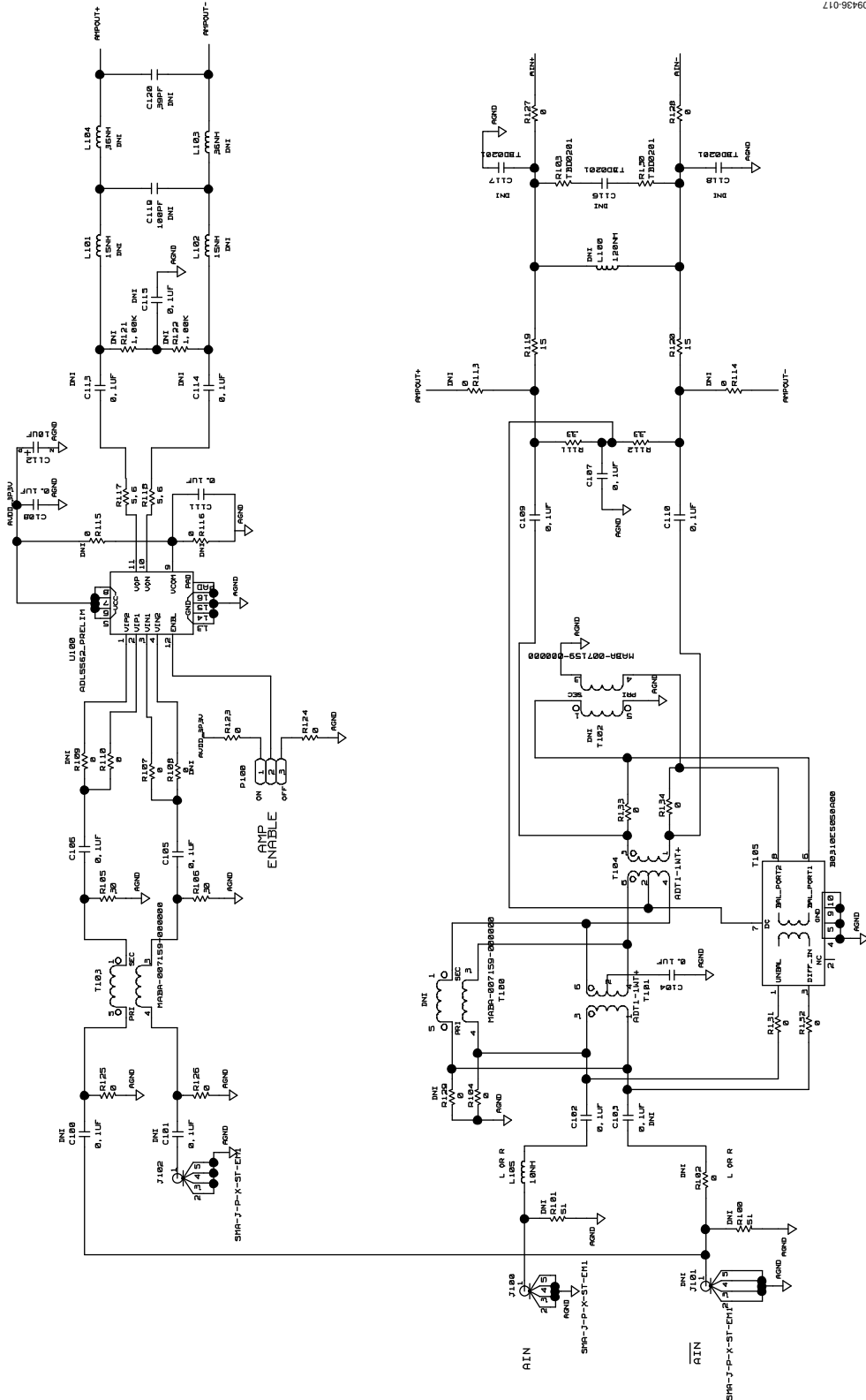
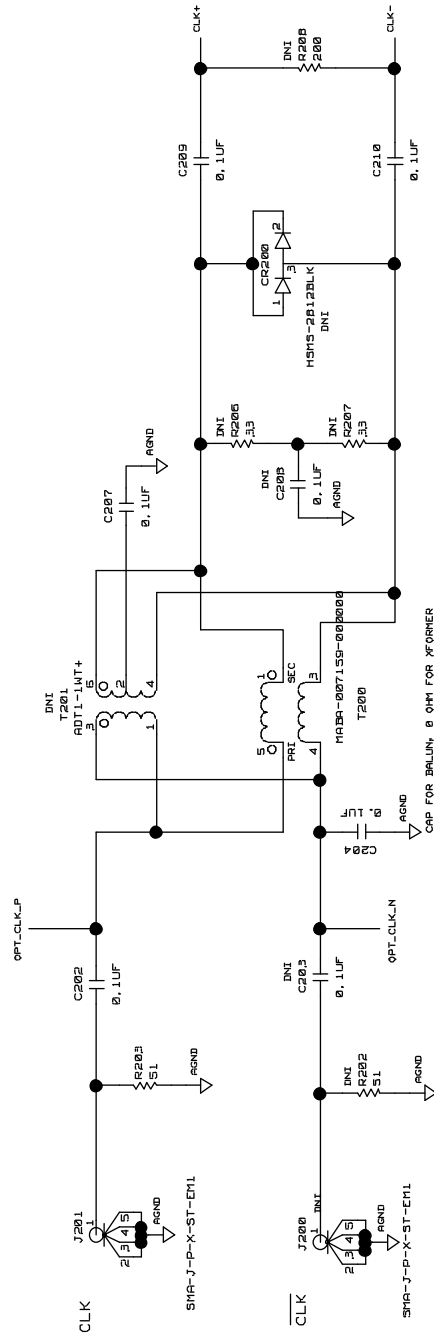

Figure 17. DUT Analog Input Circuits

CLOCK CIRCUITRY

< DEFAULT >



OPTIONAL OSCILLATOR

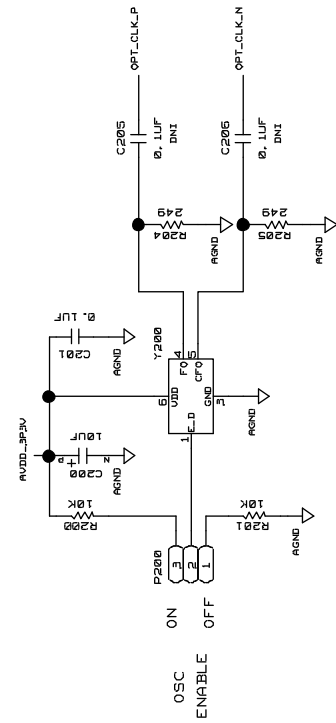

Figure 18. DUT Passive (Default) Clock Circuit

OPTIONAL CLOCK PATH CIRCUIT

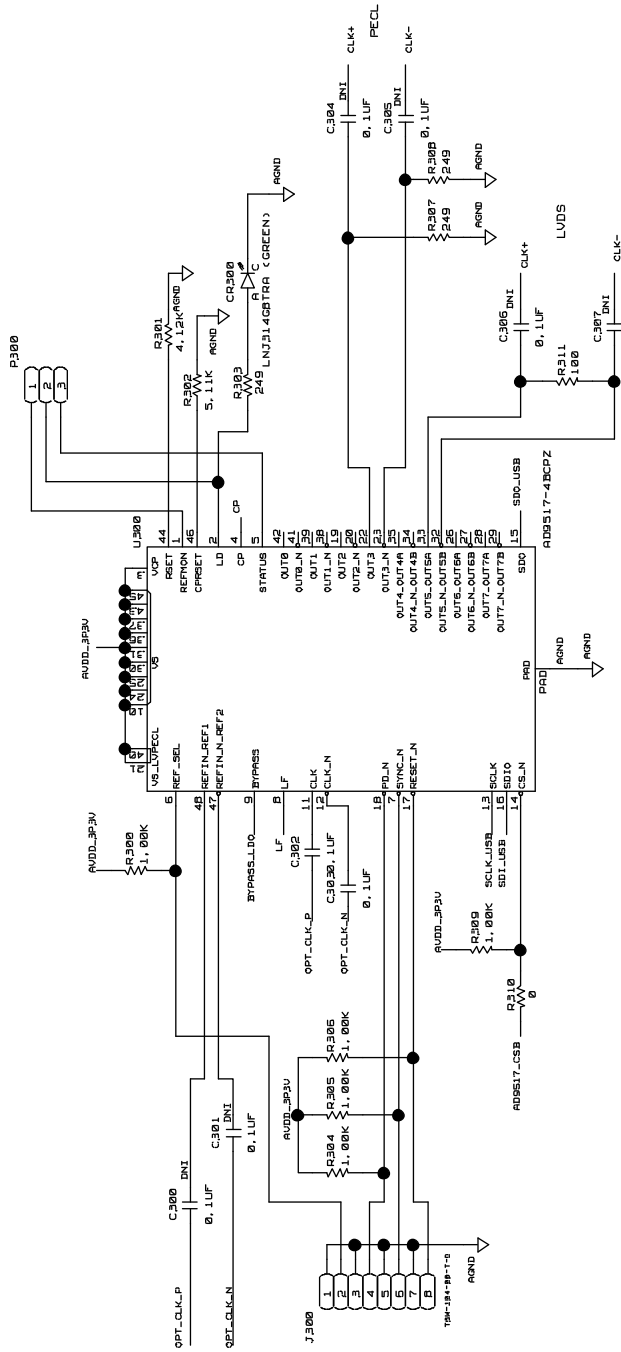
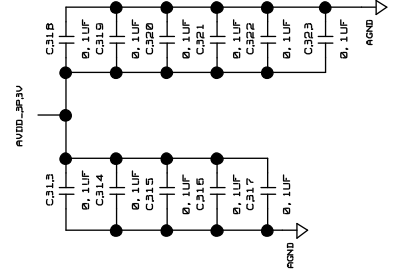
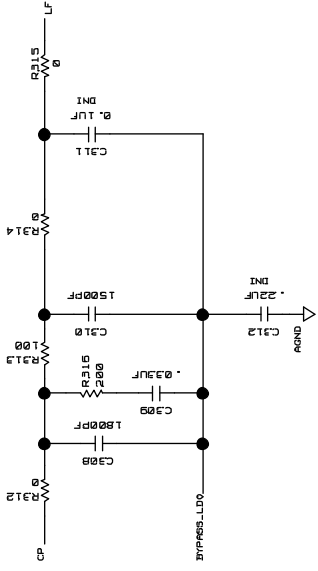

Figure 19. DUT Active Clock Circuit

DECOUPLING



CHARGE PUMP FILTER



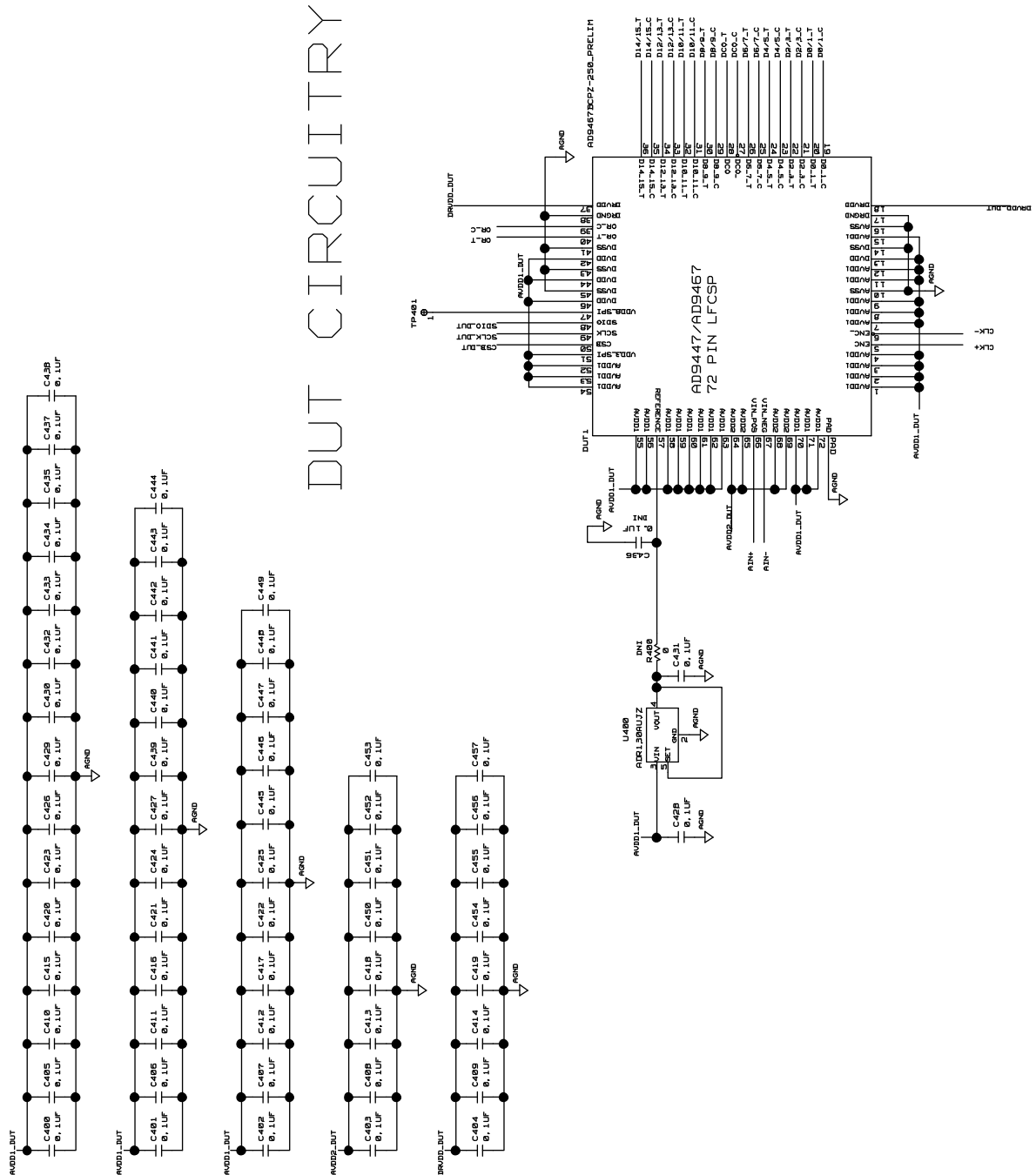

Figure 20. DUT Circuitry

OPTIONAL TERMINATION

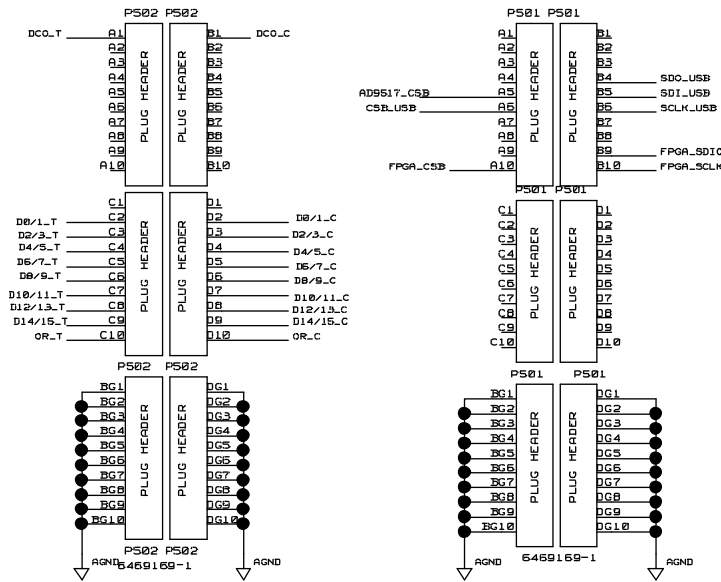
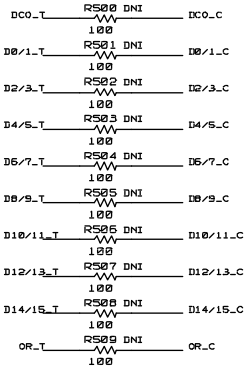

Figure 21. Digital Output Interface

09436-021

SPI CIRCUITRY

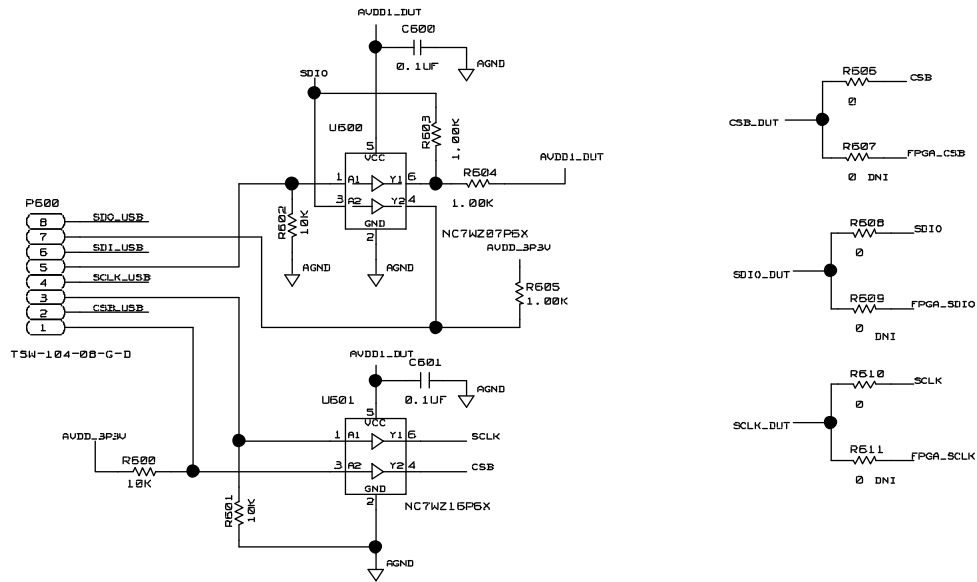

Figure 22. SPI Interface Circuitry

09436-022

WALWART POWER SUPPLY CIRCUITRY

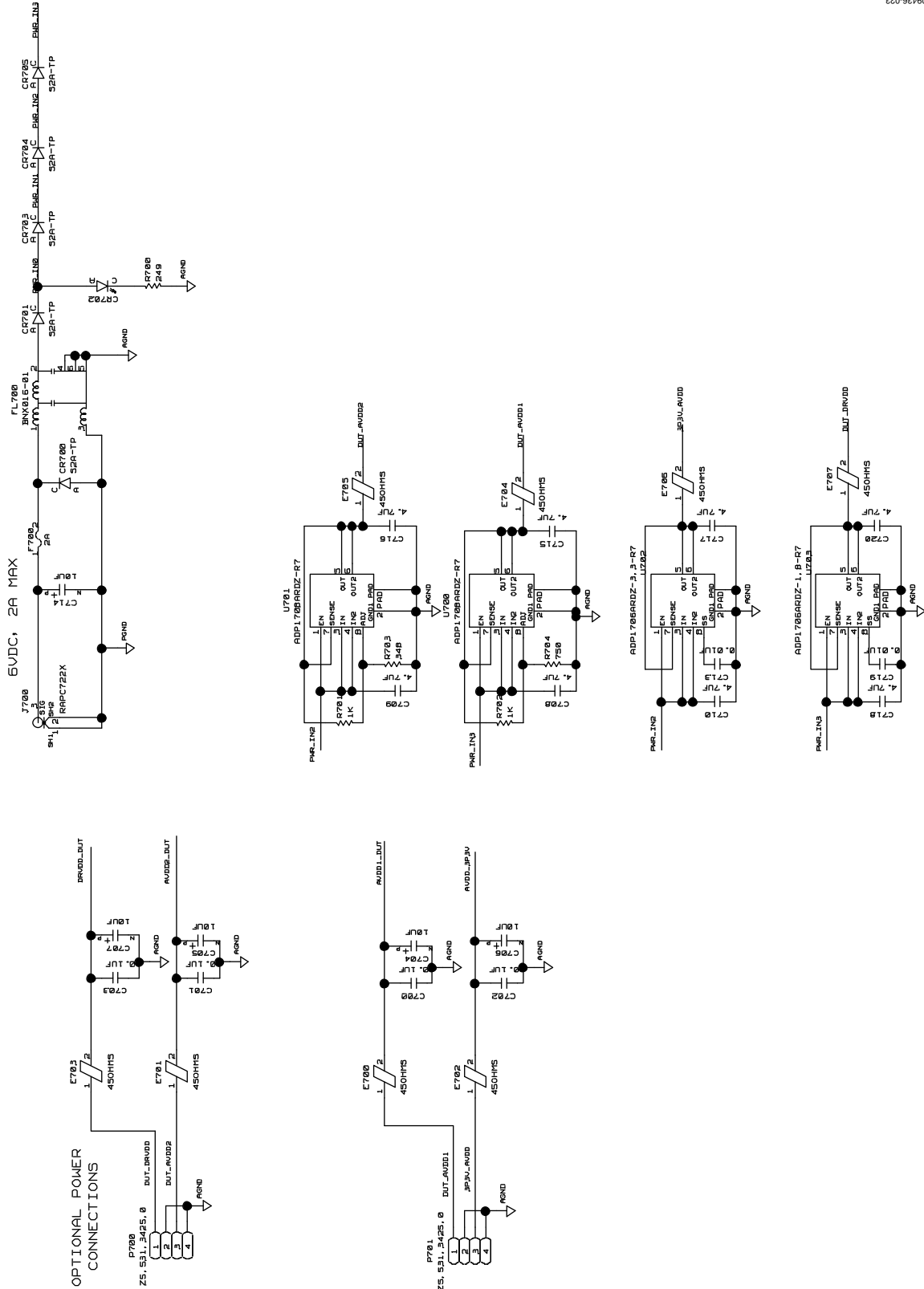

Figure 23. Power Supply Circuitry

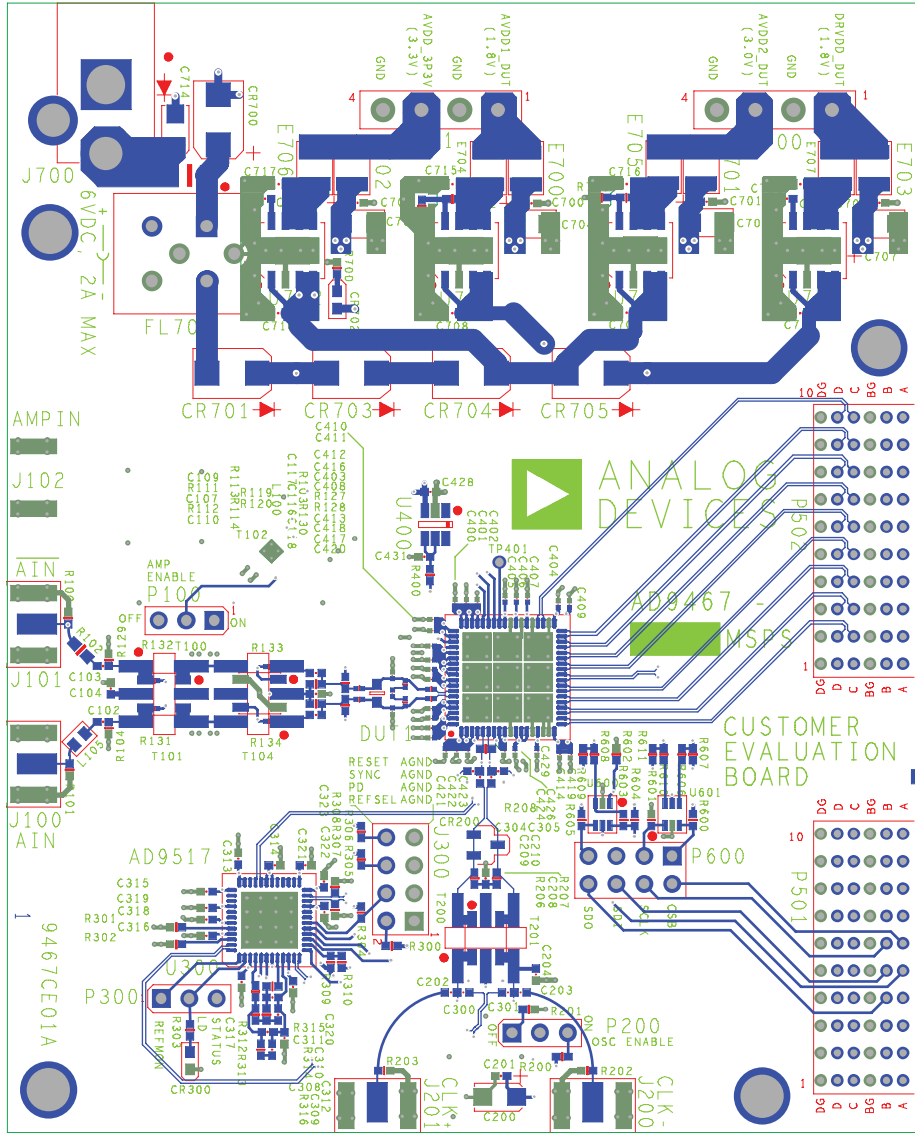

Figure 24. Top (Layer 1)

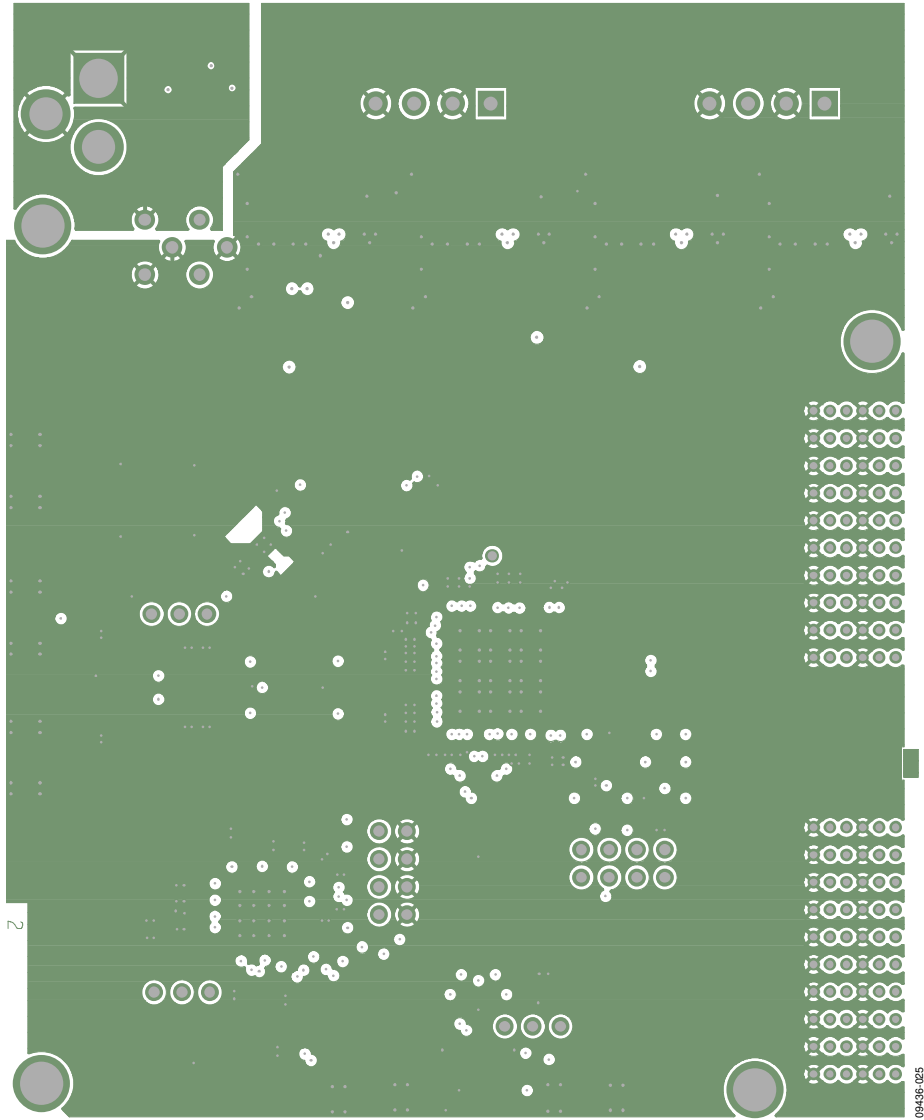

Figure 25. Ground (Layer 2)

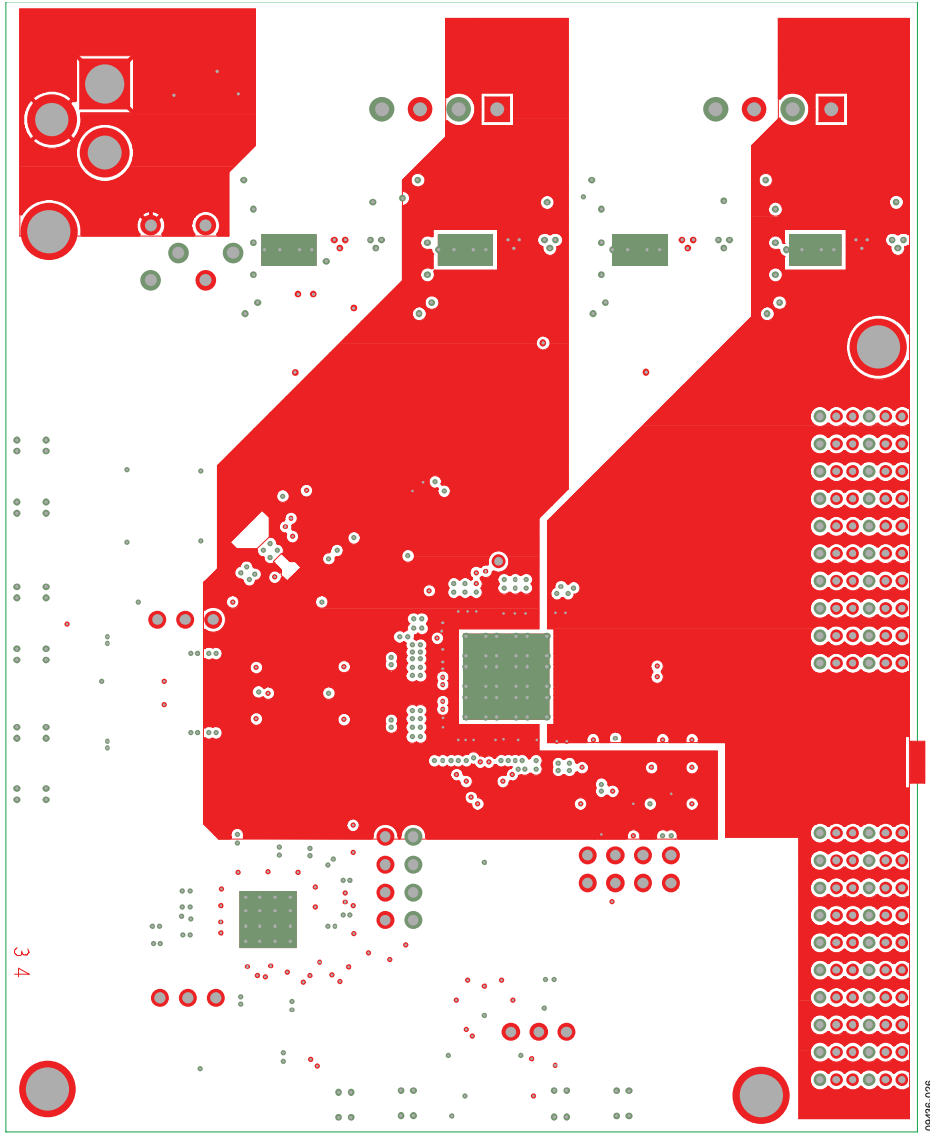

Figure 26. Power Plane (Layer 3)

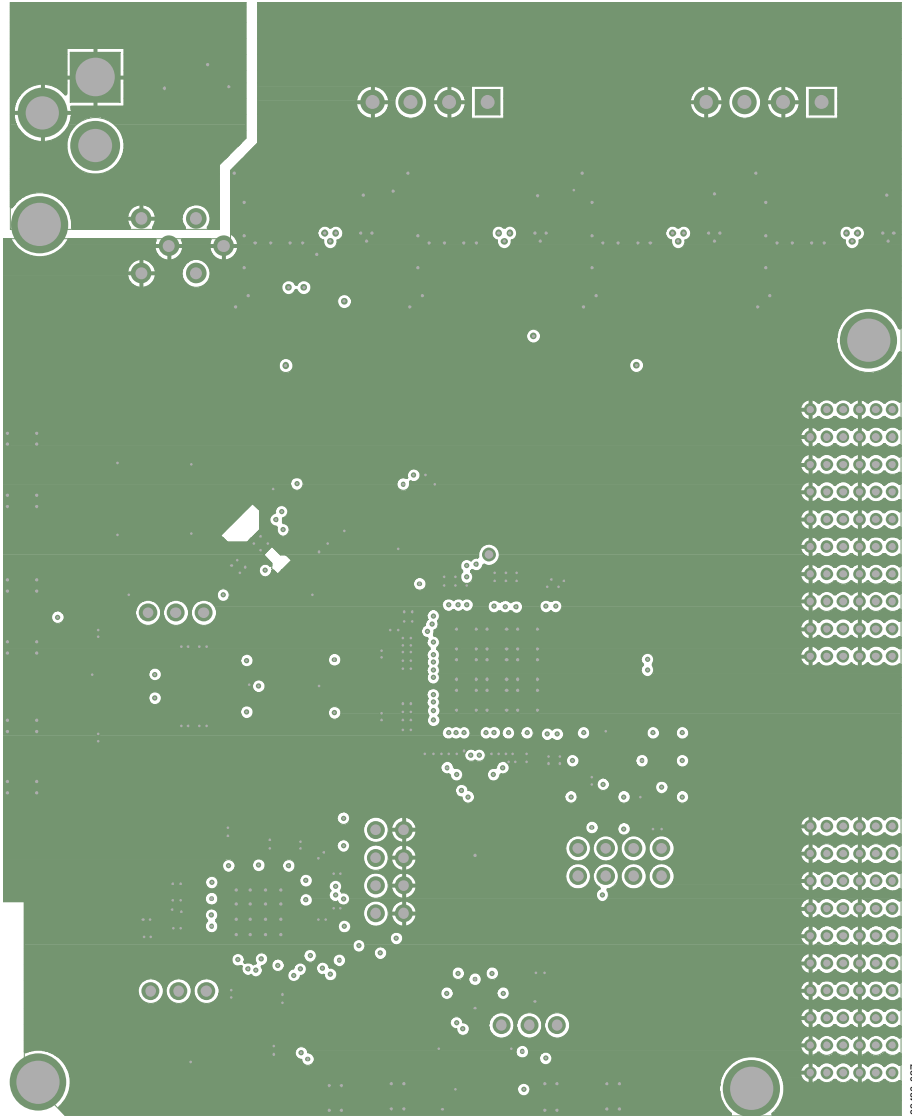

Figure 27. Ground Plane (Layer 4)

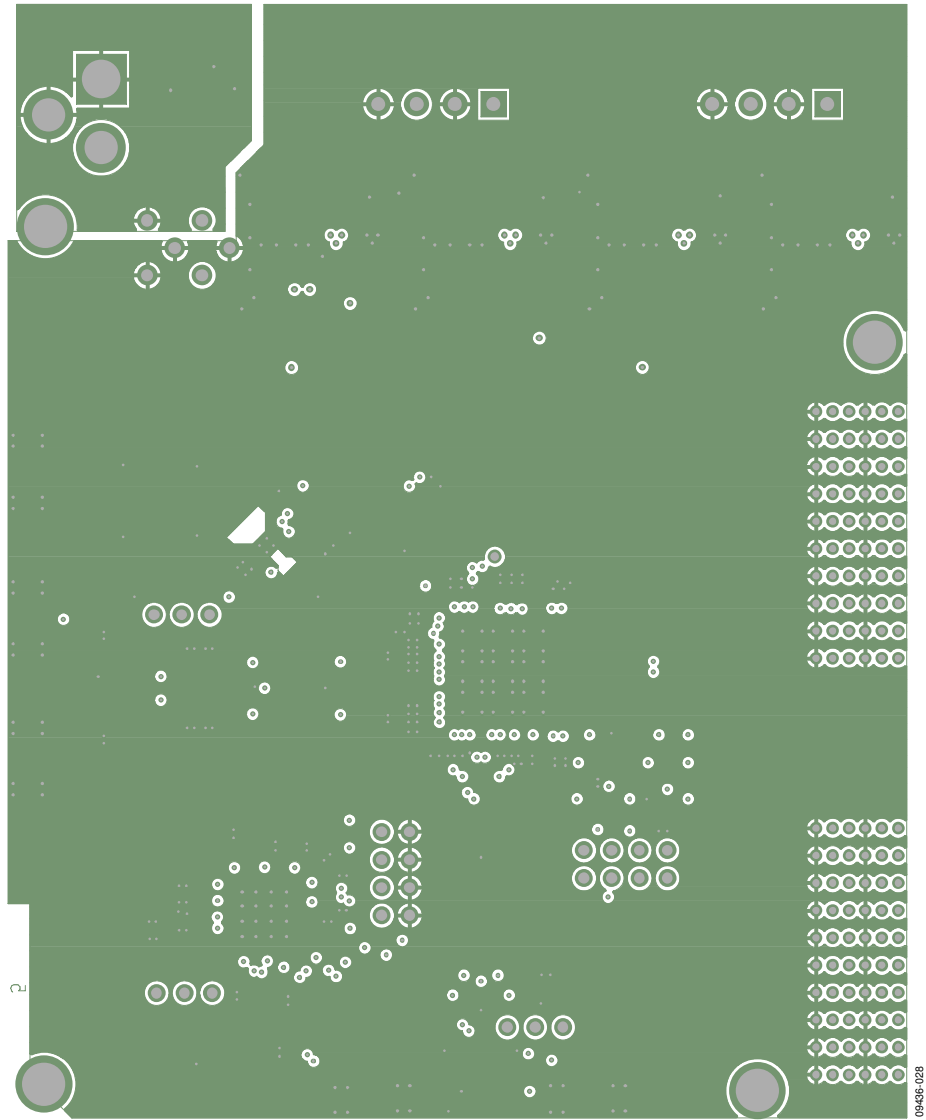

Figure 28. Ground Plane (Layer 5)

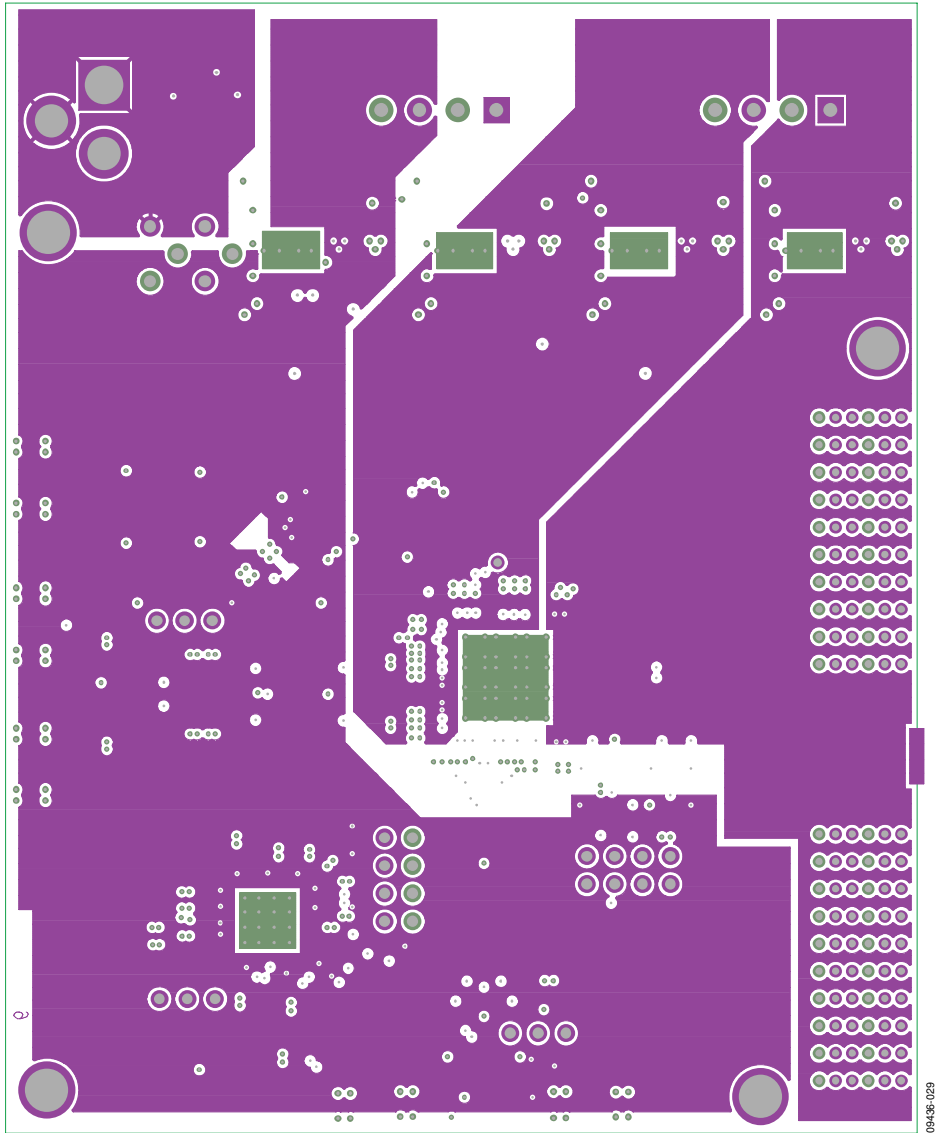

Figure 29. Power Plane (Layer 6)

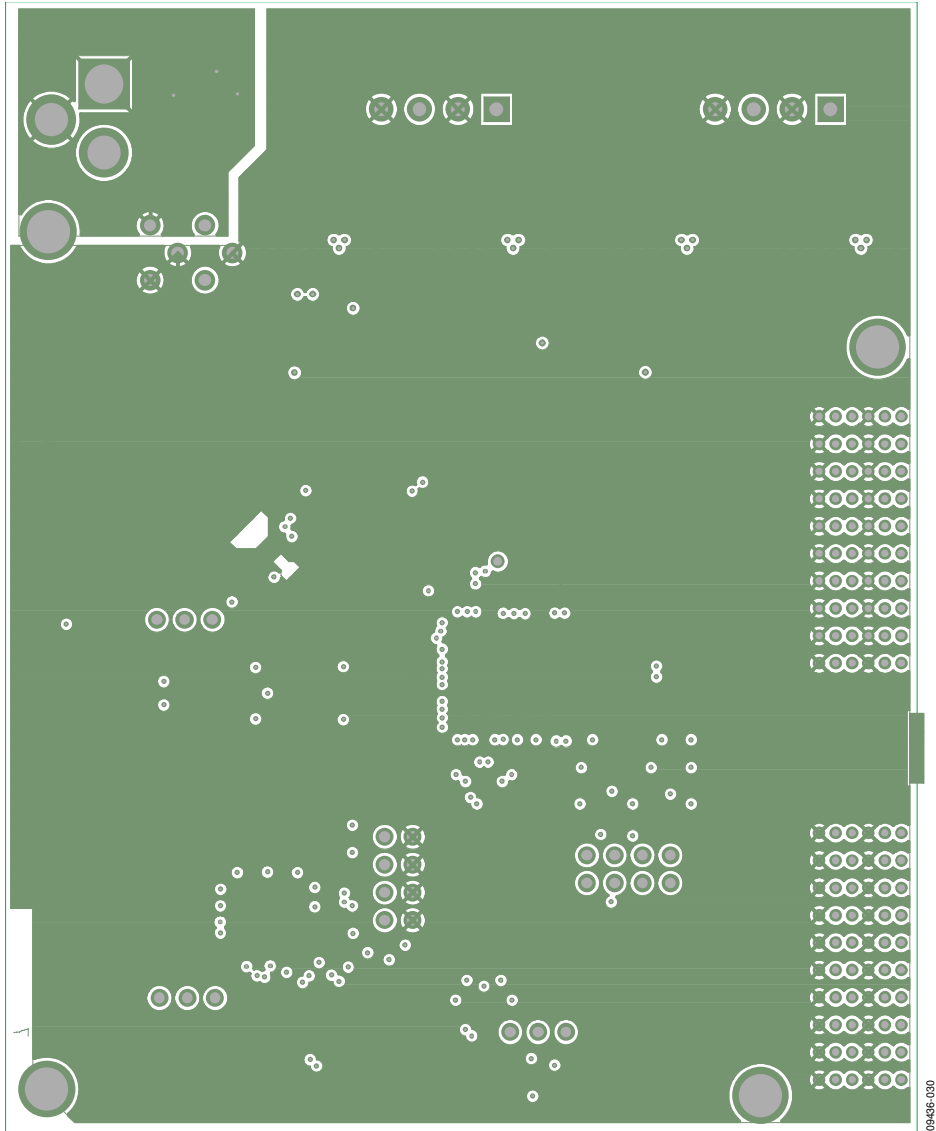

Figure 30. Ground Plane (Layer 7)

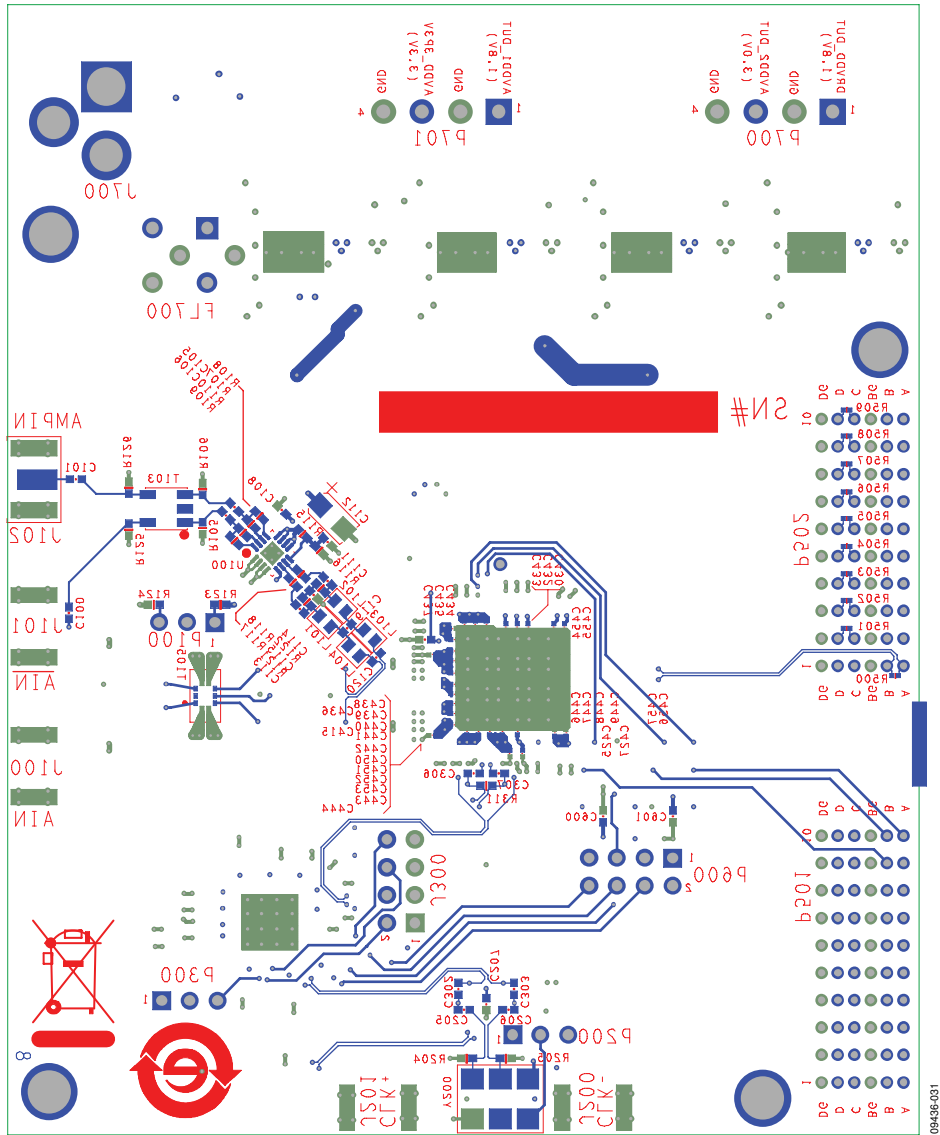

Figure 31. Bottom Side (Layer 8)

ORDERING INFORMATION

BILL OF MATERIALS

Table 1.

Item	Qty	Reference Designator	Description	Manufacturer	Part Number
1	1	9467CE01A	PCB		
2	38	C101, C102, C104, C105, C106, C107, C108, C109, C110, C111, C201, C202, C204, C207, C208, C209, C210, C302, C303, C313, C314, C315, C316, C317, C318, C319, C320, C321, C322, C323, C428, C431, C600, C601, C700, C701, C702, C703	Capacitor, 0.1 μ F, 0402, X7R, ceramic	Murata	GRM155R71C104KA88D
3	7	C112, C200, C704, C705, C706, C707, C714	Capacitor tantalum, 10 μ F, 10 V, 10%, SMD	AVX	TAJA106K010RNJ
4	1	C308	Capacitor, 1800 pF, 25 V, ceramic, 0402, SMD	Panasonic	ECJ-0EB1E182K
5	1	C309	Capacitor, ceramic, 0.033 μ F, 10%, 16 V, X5R, 0402	Panasonic	0402YD333KAT2A
6	1	C310	Capacitor, 1500 pF, 0402, 25 V, ceramic, X7R	Panasonic	ECJ-0EB1E152K
7	55	C400, C401, C402, C403, C404, C405, C406, C407, C408, C409, C410, C411, C412, C413, C414, C415, C416, C417, C418, C419, C420, C421, C422, C423, C424, C425, C426, C427, C429, C430, C432, C433, C434, C435, C437, C438, C439, C440, C441, C442, C443, C444, C445, C446, C447, C448, C449, C450, C451, C452, C453, C454, C455, C456, C457	Capacitor, ceramic, 0.1 μ F, 6.3 V, X5R, 0201	Murata	GRM033R60J104KE19D
8	8	C708, C709, C710, C715, C716, C717, C718, C720	Capacitor, ceramic, 4.7 μ F, 6.3 V, X5R, 0603	Murata	GRM188R60J475KE19D
9	2	C713, C719	Capacitor, 10,000 pF, 0402, 16 V, ceramic, X7R	Panasonic	ECJ-0EB1C103K
10	1	C116	Capacitor, ceramic, 1.8 pF, 25 V, C0G 0201	Murata	GRM0335C1E1R8CD01D
11	2	CR300, CR702	LED green USS type 0603	Panasonic	LNJ314G8TRA
12	5	CR700, CR701, CR703, CR704, CR705	Rectifier SIL 2A 50 V DO-214AA	Micro Commercial Components Corp	S2A-TP
13	1	CR200	Diode Schottky dual series	Avago	HSMS-2812BLK
14	8	E700, E701, E702, E703, E704, E705, E706, E707	Bead core 3.2 \times 2.5 \times 1.6 SMD T/R, 45 Ω @ 100 MHz	Panasonic	EXCCL3225U1
15	1	F700	Polyswitch 1.10 A reset fuse SMD	Tyco/Raychem	NANOSMDC110F-2
16	1	FL700	EMI filter LC block choke coil	Murata	BNX016-01
17	3	J100, J102, J201	SMA, end launch, COAX	Samtec	SMA-J-P-H-ST-EM1
18	2	J300, P600	CONN-PCB header 8-pin double row	Samtec	TSW-104-08-T-D
19	1	J700	Power supply connector	Switchcraft	RAPC722X
20	1	L105	Inductor SM, 10 nH	Coilcraft	0603CS-10NXJLW
21	3	P100, P200, P300	Conn-PCB BERG HDR ST male 3P	Samtec	TSW-103-08-G-S
22	2	P501, P502	CONN_PCB 60-pin RA connector	Tyco	6469169-1
23	13	R107, R110, R123, R124, R125, R129, R310, R312, R314, R315, R606, R608, R610	Resistor, 0 Ω , 0402, 1/16 W, 1%	Panasonic	ERJ-2GE0R00X

Item	Qty	Reference Designator	Description	Manufacturer	Part Number
24	2	R117, R118	Resistor, 5.60 Ω , 1/16 W, 1%, 0402, SMD	Vishay/Dale	CRCW04025R60FNED
25	2	R119, R120	Resistor, 15 Ω , 1/20 W, 5%, 0201, SMD	Panasonic	ERJ-1GEJ150C
26	2	R206, R207	Resistor, 33 Ω , 1/10 W, 5%, 0402, SMD	Panasonic	ERJ-2GEJ330X
27	4	R105, R106, R111, R112	Resistor, 33 Ω , 1/10 W, 5%, 0402, SMD	Panasonic	ERJ-2GEJ330X
28	5	R200, R201, R600, R601, R602	Resistor, 10.0 k Ω , 0402, 1/16 W, 1%	Panasonic	ERJ-2RKF1002X
29	2	R127, R128	Resistor, 0.0 Ω , 1/20 W, 0201, SMD	Panasonic	ERJ-1GE0R00C
30	6	R204, R205, R303, R307, R308, R700	Resistor, 249 Ω , 0402, 1/16 W, 1%	Panasonic	ERJ-2RKF2490X
31	10	R300, R304, R305, R306, R309, R603, R604, R605, R701, R702	Resistor, 1.00 k Ω , 0402, 1/16 W, 1%	Panasonic	ERJ-2RKF1001X
32	1	R704	Resistor, 750 Ω , 1/10 W, 5%, 0402, SMD	Panasonic	ERJ-2GEJ751X
33	1	R703	Resistor, 316 Ω , 0402, 1/16 W, 1%	Panasonic	ERJ-2RKF3160X
34	1	R301	Resistor, 4.12 k Ω , 0402, 1/10 W, 1%	Panasonic	ERJ-2RKF4121X
35	1	R302	Resistor, 5.1 k Ω , 0402, 1/16 W, 5%	Panasonic	ERJ-2GEJ512X
36	1	R316	Resistor, 200 Ω , 1/10 W, 1%, 0402, SMD	Panasonic	ERJ-2RKF2000X
37	2	R103, R130	Resistor, 20 Ω , 1/20 W, 5%, 0201, SMD	Panasonic	ERJ-1GEJ200C
38	2	R311, R313	Resistor, 100 Ω , 1/10 W, 5%, 0402, SMD	Panasonic	ERJ-2GEJ101X
39	2	T101, T104	XFMR, 1:1 impedance ratio	Minicircuits	ADT1-1WT+
40	2	T103, T200	Balun, 1:1 impedance ratio	Macom	MABA-007159-000000
41	1	T105	Balun, 1:1 impedance ratio	Anaren	BD0205F5050A00
42	1	DUT1	IC-ADI LFCSP 10 mm \times 10 mm plus EPAD	Analog Devices	AD9467BCPZ-250
43	1	U100	IC 2.6 GHz ultralow distortion differential IF/RF amplifier	Analog Devices	ADL5562ACPZ-R7
44	1	U300	IC-ADI 12-output CLK GEN with INT 1.6 GHZ VCO	Analog Devices	AD9517-4BCPZ
45	1	U400	IC, voltage ref, precision series, SOT23_6	Analog Devices	ADR130AUJZ
46	1	U600	IC tinylogic UHS dual buffer	Fairchild	NC7WZ07P6X
47	1	U601	IC tinylogic UHS dual buffer	Fairchild	NC7WZ16P6X
48	2	U700, U701	IC, regulator 0.8 V to 5.0 V, low dropout CMOS, SO8	Analog Devices	ADP1708ARDZ-R7
49	1	U702	IC-ADI low dropout CMOS linear regulator	Analog Devices	ADP1706ARDZ-3.3-R7
50	1	U703	IC-ADI low dropout CMOS linear regulator	Analog Devices	ADP1706ARDZ-1.8-R7
51	1	Y200	250 MHz, XTAL 3.3 V LVPECL OSC	Vectron	VCC6-QCD-250M000

Item	Qty	Reference Designator	Description	Manufacturer	Part Number
52	7	MP101, MP102, MP103, MP104, MP105, MP106, MP107	Part of assembly, 100 mil jumpers, place into P100 (Pin 2 to Pin 3), P200 (Pin 1 to Pin 2), J300 (Pin 3 to Pin 4), P600 (Pin 1 to Pin 2, Pin 3 to Pin 4, Pin 5 to Pin 6, Pin 7 to Pin 8)	SAMTEC	SNT-100-BK-G-H
53	4	MP111, MP112, MP113, MP114	Part of assembly, insert/snap into the large holes from the bottom side of board, 14 mm height, dual locking standoffs for circuit board support	RICHCO	CBSB-14-01

NOTES

**ESD Caution**

ESD (electrostatic discharge) sensitive device. Charged devices and circuit boards can discharge without detection. Although this product features patented or proprietary protection circuitry, damage may occur on devices subjected to high energy ESD. Therefore, proper ESD precautions should be taken to avoid performance degradation or loss of functionality.

Legal Terms and Conditions

By using the evaluation board discussed herein (together with any tools, components documentation or support materials, the "Evaluation Board"), you are agreeing to be bound by the terms and conditions set forth below ("Agreement") unless you have purchased the Evaluation Board, in which case the Analog Devices Standard Terms and Conditions of Sale shall govern. Do not use the Evaluation Board until you have read and agreed to the Agreement. Your use of the Evaluation Board shall signify your acceptance of the Agreement. This Agreement is made by and between you ("Customer") and Analog Devices, Inc. ("ADI"), with its principal place of business at One Technology Way, Norwood, MA 02062, USA. Subject to the terms and conditions of the Agreement, ADI hereby grants to Customer a free, limited, personal, temporary, non-exclusive, non-sublicensable, non-transferable license to use the Evaluation Board FOR EVALUATION PURPOSES ONLY. Customer understands and agrees that the Evaluation Board is provided for the sole and exclusive purpose referenced above, and agrees not to use the Evaluation Board for any other purpose. Furthermore, the license granted is expressly made subject to the following additional limitations: Customer shall not (i) rent, lease, display, sell, transfer, assign, sublicense, or distribute the Evaluation Board; and (ii) permit any Third Party to access the Evaluation Board. As used herein, the term "Third Party" includes any entity other than ADI, Customer, their employees, affiliates and in-house consultants. The Evaluation Board is NOT sold to Customer; all rights not expressly granted herein, including ownership of the Evaluation Board, are reserved by ADI. CONFIDENTIALITY. This Agreement and the Evaluation Board shall all be considered the confidential and proprietary information of ADI. Customer may not disclose or transfer any portion of the Evaluation Board to any other party for any reason. Upon discontinuation of use of the Evaluation Board or termination of this Agreement, Customer agrees to promptly return the Evaluation Board to ADI. ADDITIONAL RESTRICTIONS. Customer may not disassemble, decompile or reverse engineer chips on the Evaluation Board. Customer shall inform ADI of any occurred damages or any modifications or alterations it makes to the Evaluation Board, including but not limited to soldering or any other activity that affects the material content of the Evaluation Board. Modifications to the Evaluation Board must comply with applicable law, including but not limited to the RoHS Directive. TERMINATION. ADI may terminate this Agreement at any time upon giving written notice to Customer. Customer agrees to return to ADI the Evaluation Board at that time. LIMITATION OF LIABILITY. THE EVALUATION BOARD PROVIDED HEREUNDER IS PROVIDED "AS IS" AND ADI MAKES NO WARRANTIES OR REPRESENTATIONS OF ANY KIND WITH RESPECT TO IT. ADI SPECIFICALLY DISCLAIMS ANY REPRESENTATIONS, ENDORSEMENTS, GUARANTEES, OR WARRANTIES, EXPRESS OR IMPLIED, RELATED TO THE EVALUATION BOARD INCLUDING, BUT NOT LIMITED TO, THE IMPLIED WARRANTY OF MERCHANTABILITY, TITLE, FITNESS FOR A PARTICULAR PURPOSE OR NON-INFRINGEMENT OF INTELLECTUAL PROPERTY RIGHTS. IN NO EVENT WILL ADI AND ITS LICENSORS BE LIABLE FOR ANY INCIDENTAL, SPECIAL, INDIRECT, OR CONSEQUENTIAL DAMAGES RESULTING FROM CUSTOMER'S POSSESSION OR USE OF THE EVALUATION BOARD, INCLUDING BUT NOT LIMITED TO LOST PROFITS, DELAY COSTS, LABOR COSTS OR LOSS OF GOODWILL. ADI'S TOTAL LIABILITY FROM ANY AND ALL CAUSES SHALL BE LIMITED TO THE AMOUNT OF ONE HUNDRED US DOLLARS (\$100.00). EXPORT. Customer agrees that it will not directly or indirectly export the Evaluation Board to another country, and that it will comply with all applicable United States federal laws and regulations relating to exports. GOVERNING LAW. This Agreement shall be governed by and construed in accordance with the substantive laws of the Commonwealth of Massachusetts (excluding conflict of law rules). Any legal action regarding this Agreement will be heard in the state or federal courts having jurisdiction in Suffolk County, Massachusetts, and Customer hereby submits to the personal jurisdiction and venue of such courts. The United Nations Convention on Contracts for the International Sale of Goods shall not apply to this Agreement and is expressly disclaimed.