

PART NUMBER	REV	FIRST USED
466317-1	A	954400-1
466317-2	C	565435-5

OBSOLETE

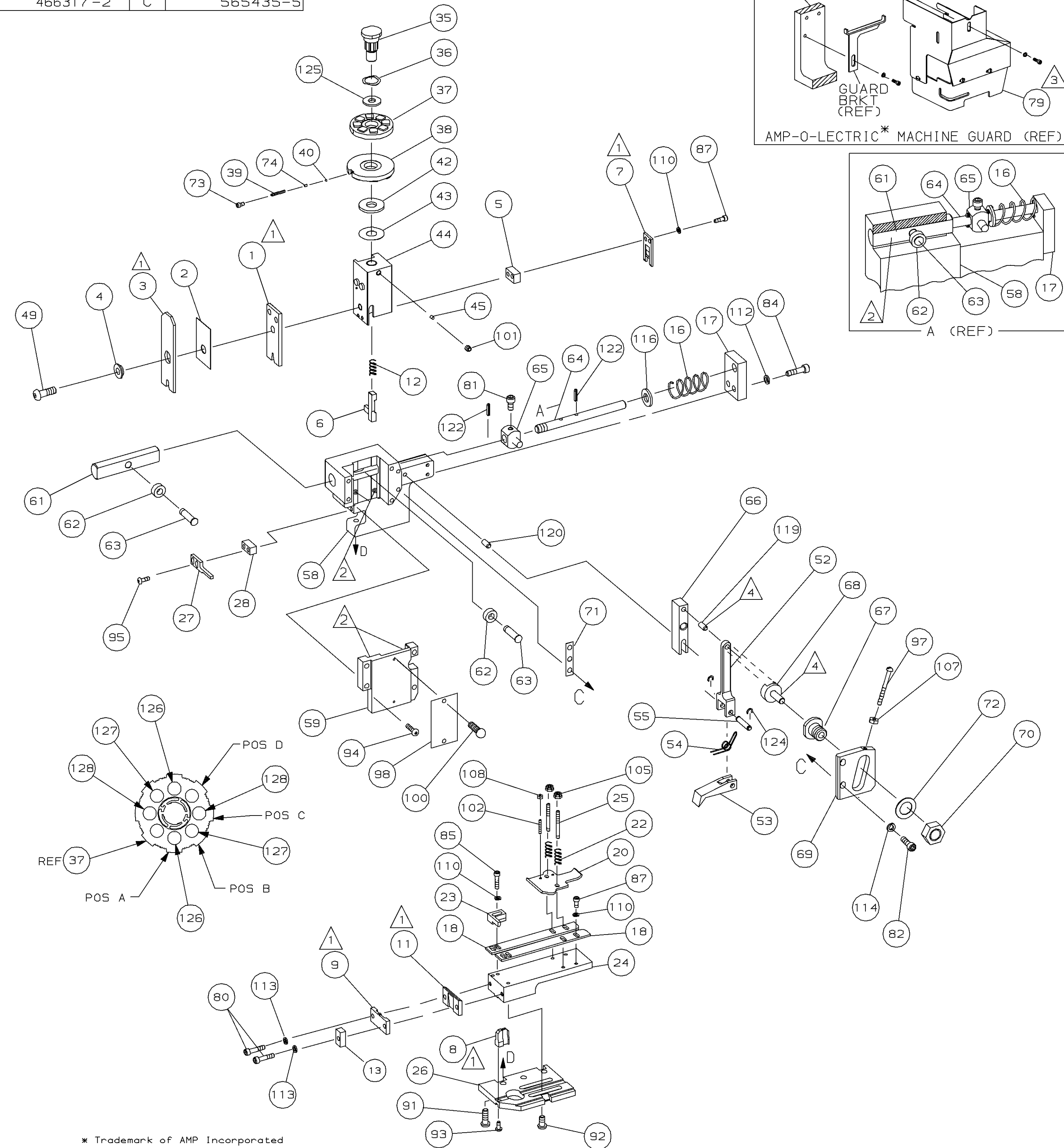

\* Trademark of AMP Incorporated

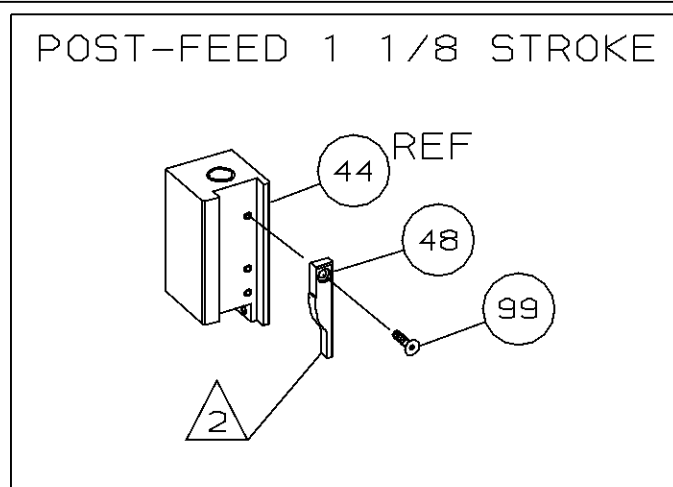
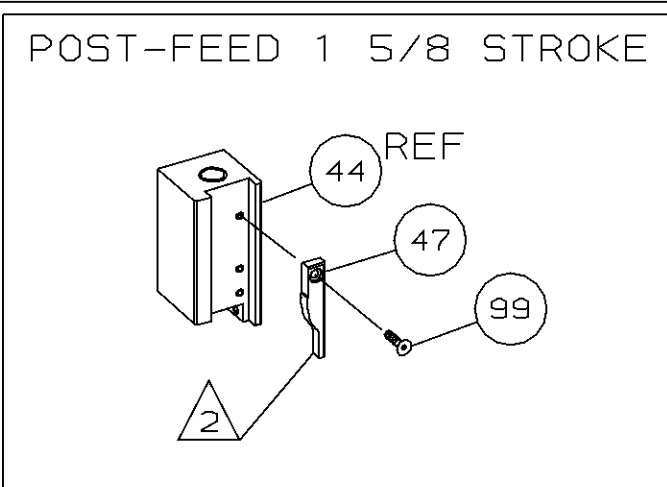

- 1 RECOMMENDED SPARE PARTS.
- 2 GREASE LIGHTLY.
- 3 GUARD MUST BE IN PLACE WHEN OPERATING APPLICATOR IN AMP-O-ELECTRIC MACHINE.
- 4 LUBRICATE DAILY USING NO. 20 MACHINE OIL.
- 5. ITEMS WITH QTY OF REF SPECIFIED (EXCEPT ITEM 79) ARE USED ON ITEM 32.

LOC A  
DIST 66  
LEADMAKER  
T TERMINATING UNIT

AMP-O-ELECTRIC  
KTERMINATING UNIT

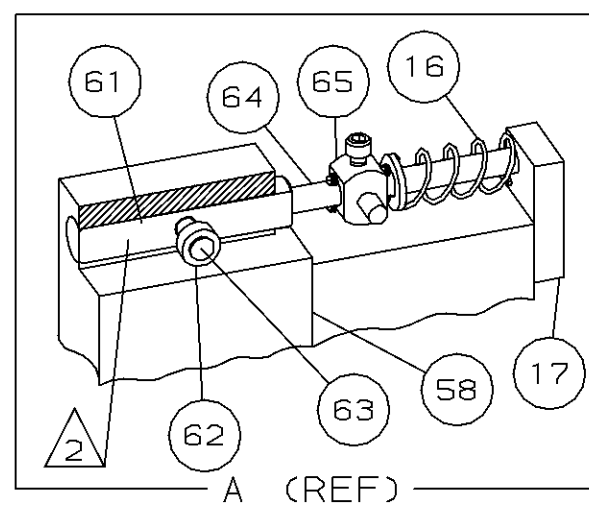
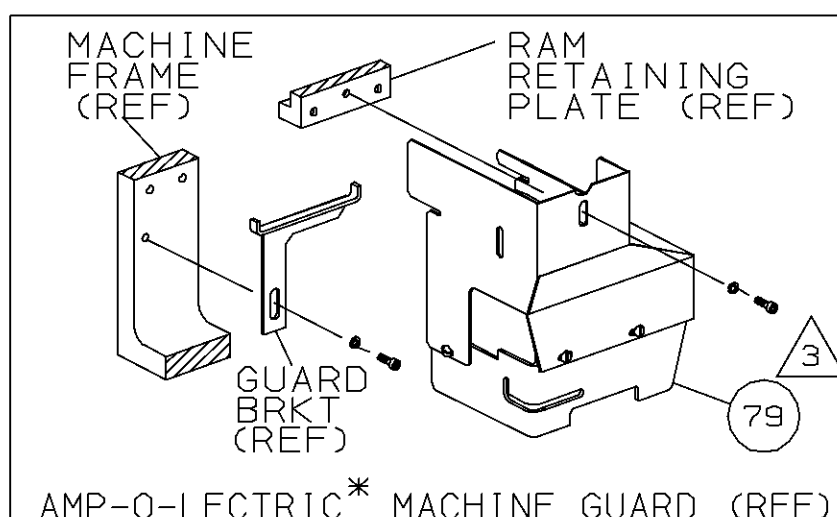

TERMINAL NAME:		CRIMPING DATA			
.250 FASTON RECEPTACLE		PAD LTR	CRIMP HEIGHT	WIRE SIZE	
735213		A	.062 ±.002	14	
		B	.060 ±.002	16	
		C	.058 ±.002	18	
		D	NOT USED		
		CRIMP	SIZE	TYPE	RANGE
		WIRE	.110	F	18-14
		INSUL	.180	F	.120-.170
		FEED	APPL INST	SET UP GAGE	LAYOUT
		.740	408-8039	458638-1	615
TERM APPL SPEC -		WIRE STRIP LENGTH -			

QTY	REV	U/M	DWG SIZE	PART NO	DESCRIPTION	ITEM NO
2	2	-	C	354779-6	PIN, WIRE DISC (.3020)C	128
2	2	-	C	354779-2	PIN, WIRE DISC (.3000)B	127
2	2	-	C	354779-8	PIN, WIRE DISC (.3030)A	126
1	1	-	A	986950-1	WASHER, FLAT PRECISION	125
REF	REF	-	A	21045-3	RING, RET "C" (Ø.187)FD PIN	124
REF	REF	-	A	5-21028-1	PIN, STD SPRING (Ø.12)FD ADJ ROD	122
REF	REF	-	A	1-21030-7	PIN, DOWEL (Ø.187x1.50)HSG	120
REF	REF	-	A	1-21030-1	PIN, DOWEL (Ø.187x.50)LEVER	119
REF	REF	-	A	21899-4	WASHER, FLAT (Ø5/16)SCR ADJ	116
REF	REF	-	A	21024-5	WASHER, LOCK (NO.10)FD ADJ PL	114
2	2	-	A	21024-5	WASHER, LOCK (NO.10)SHEAR PL	113
REF	REF	-	A	21024-5	WASHER, LOCK (NO.10)FD ROD GDE	112
7	7	-	A	21024-4	WASHER, LOCK (NO.8)SHEAR BL	110
2	2	-	A	21018-4	NUT, HEX (4-40)DRAG	108
REF	REF	-	A	21018-5	NUT, HEX (6-32)FD ADJ PL	107
2	2	-	A	21022-2	NUT, HEX SL (8-32)DRAG STUD	105
2	2	-	A	4-21078-8	SKT SKT SET (4-40x.75)DRAG	102
1	1	-	A	21009-2	SCR, SKT SET (1/4-20x.25 )RAM	101
2	2	-	A	21017-2	SCR, DRIVE (#2x.19) ID PLATE	100
1	1	-	A	1-21002-7	SCR, BHC (6-32x.38)CAM	99
1	1	-	B	461264-1	PLATE, IDENTIFICATION	98
REF	REF	-	A	6-23715-5	SCR, PAN HD (6-32x1.50)FEED ADJ	97
2	2	-	A	2-21002-2	SCR, BHC (8-32x.50)STRIPPER	95
REF	REF	-	A	2-21002-9	SCR, BHC (10-32x.75)HSG CAP	94
1	1	-	A	22733-8	SCR, BHC (8-32x.38 LW)ANVIL	93
4	4	-	A	3-21002-3	SCR, BHC (1/4-20x.50)ST 6D PL	92
REF	REF	-	A	2-22733-8	SCR, BHC (1/4-20x.62)BASE PL	91
1	1	-	A	690603-1	SPRING, ASSIST	74
1	1	-	A	23030-1	SCR, SKT CAP (6-32x.25)CP DSC	73
REF	REF	-	A	458109-1	WASHER, FLAT (SPECIAL)	72
REF	REF	-	A	690517-1	SPACER	71
-2	-1	U/M	DWG SIZE	PART NO	DESCRIPTION	ITEM NO
REVISION OF EACH ASSY NO (WHEN BLANK, USE DWG REVISION)						
QTY REQD PER ASSY						

QTY	REV	U/M	DWG SIZE	PART NO	DESCRIPTION	ITEM NO
-1				LEADMAKER	MECH-POST FEED	
-2				AMP-O-ELECTRIC	MECH-POST FEED	
REF	REF	-	A	22594-8	NUT, HEX	70
REF	REF	-	B	240628-1	PLATE, ADJ	69
REF	REF	-	B	240626-1	SHAFT, PIVOT	68
REF	REF	-	B	240633-1	BUSHING	67
REF	REF	-	A	455680-1	LEVER, INTERMEDIATE	66
REF	REF	-	B	240629-1	BLOCK, PIVOT	65
REF	REF	-	A	240632-2	SCR, ADJ	64
REF	REF	-	B	240659-3	PIN, CAM ROLLER	63
REF	REF	-	B	240658-1	CAM, ROLLER	62
REF	REF	-	B	454398-1	ROD, FEED	61
REF	REF	-	C	454220-1	CAP, RAM	59
REF	REF	-	D	453736-1	HOUSING	58
REF	REF	-	B	240624-1	PIN, FEED FINGER	55
REF	REF	-	B	691499-1	SPRING, FEED FINGER	54
REF	REF	-	B	240635-1	FINGER, FEED	53
REF	REF	-	B	240634-1	LEVER, TERMINAL	52
1	1	-	A	7-21002-9	BOLT, CRIMPER (5/16-24x1.00)	49
1	1	-	B	690501-3	CAM, POST FEED 1 1/8 ST	48
-	-	-	B	690501-4	CAM, POST-FEED 1 5/8 ST	47
1	1	-	A	690191-1	PLUG, NYLON	45
1	1	-	C	455674-1	RAM	44
1	1	-	A	690125-1	WASHER, LAMINATED	43
1	1	-	A	690124-1	WASHER, RAM	42
1	1	-	A	23241-6	BALL, STEEL	40
1	1	-	A	690170-1	SPRING, COMPRESSION	39
1	1	-	C	690142-1	DISC, INSULATION	38
1	1	-	D	354777-1	WIRE DISC, PLASTIC	37
1	1	-	A	22480-5	WASHER, SPRING	36
1	1	-	B	690212-1	POST, RAM	35
1	1	-	D	458980-1	APPLICATOR, BASIC (SUB ASSY)	32
1	1	-	B	3-690451-2	SPACER, STRIPPER	28
1	1	-	A	240639-1	STRIPPER	27
REF	REF	-	C	455676-1	PLATE, BASE	26
2	2	-	A	22354-8	DRAG, STUD	25
1	1	-	B	458803-2	PLATE, STRIP GUIDE	24
1	1	-	C	240825-2	PLATE, STRIP HOLD DOWN	23
2	2	-	A	4-22281-1	SPRING, DRAG	22
1	1	-	A	454177-1	DRAG, STOCK	20
2	2	-	C	454204-3	GUIDE, STRIP (FRONT)	18
REF	REF	-	A	454178-1	GUIDE, FEED ROD	17
REF	REF	-	A	4-22284-9	SPRING, FEED RETURN	16
1	1	-	C	690481-7	SPACER, HOLD DOWN	13
1	1	-	A	23846-1	SPRING, HOLD DOWN	12
1	1	-	B	240833-2	PLATE, REAR SHEAR	11
1	1	-	B	690482-5	PLATE, FRONT SHEAR	9
1	1	-	D	2-240693-3	ANVIL	8
1	1	-	B	690474-5	BLADE, SLUG	7
1	1	-	D	1-455892-1	HOLD DOWN, TERMINAL	6
1	1	-	C	240641-6	SPACER, SLUG BLADE	5
1	1	-	B	238009-1	SPACER, BLOCK CRIMPER	4
1	1	-	C	4-456134-6	CRIMPER, INSULATION	3
1	1	-	B	455888-3	SPACER, CRIMPER	2
1	1	-	C	456408-7	CRIMPER, WIRE	1
-2	-1	U/M	DWG SIZE	PART NO	DESCRIPTION	ITEM NO
REVISION OF EACH ASSY NO (WHEN BLANK, USE DWG REVISION)						
QTY REQD PER ASSY						

DIMENSIONS IN INCHES. DO NOT SCALE PRINT. TOLERANCES UNLESS OTHERWISE SPECIFIED:

2 PLC DEC ±  
3 PLC DEC ±  
4 PLC DEC ±  
ANGLES ±  
SURF TEXTURE: REMOVE BURRS, BREAK SHARP EDGES R.015 MAX

MATL - HT TR - FIN -

DR D.SALTZER 9/20/93 APP 9-21-93 E.KOOTTE  
CHK 9-21-93 REL 11/11/93 G.OCHENIS  
C.ERISMAN

AMP Incorporated Harrisburg, PA 17105-3608

NAME END FEED HDM APPLICATOR MACHINE REF MINI APPL  
SCALE - DWG NO 466317 SHEET 1 OF 1 REV C

THIS DRAWING IS A CONTROLLED DOCUMENT FOR AMP INCORPORATED. IT IS SUBJECT TO CHANGE AND THE CONTROLLING ENGINEERING ORGANIZATION SHOULD BE CONTACTED FOR THE LATEST REVISION.

THIS INFORMATION IS CONFIDENTIAL AND IS DISCLOSED TO YOU ON CONDITION THAT NO FURTHER DISCLOSURE IS MADE BY YOU TO OTHER THAN AMP PERSONNEL WITHOUT WRITTEN AUTHORIZATION FROM AMP INCORPORATED, HARRISBURG, PA.