

PART NO.	PCS/REEL	REEL/CARTON	PCS/CARTON
151129-0001	1400	2	2800

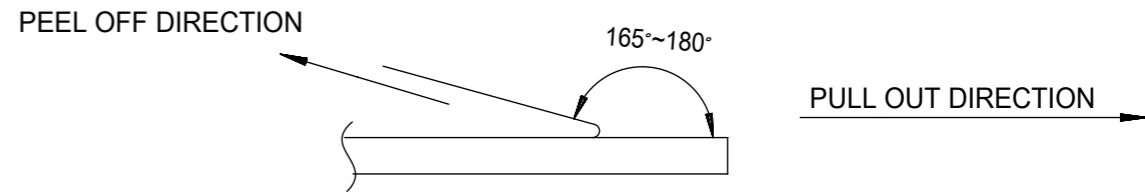

PEELING SPEED	30010MM/MIN
FORCE	10g~130g

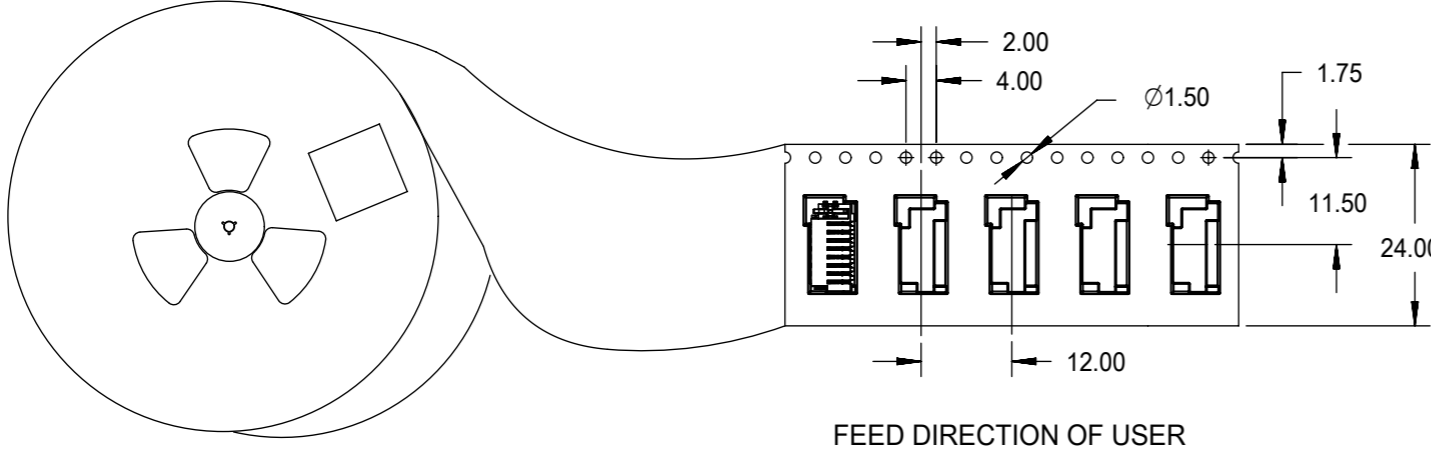
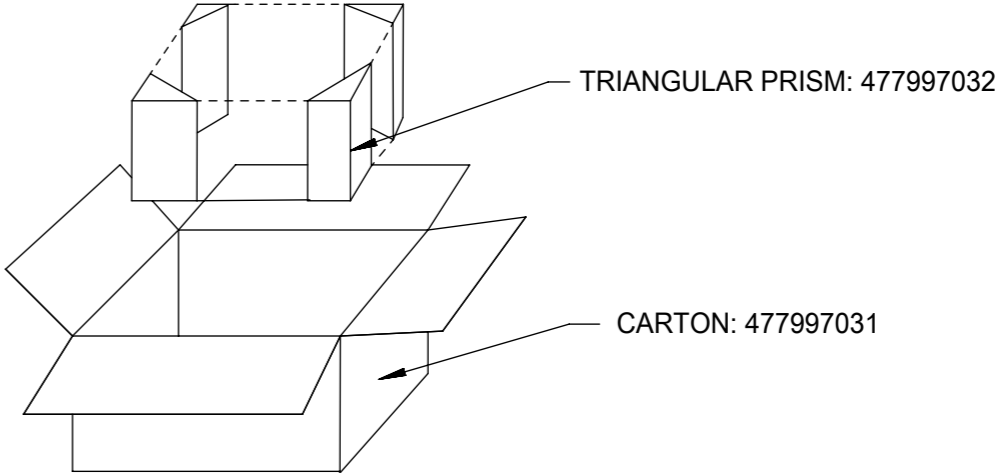
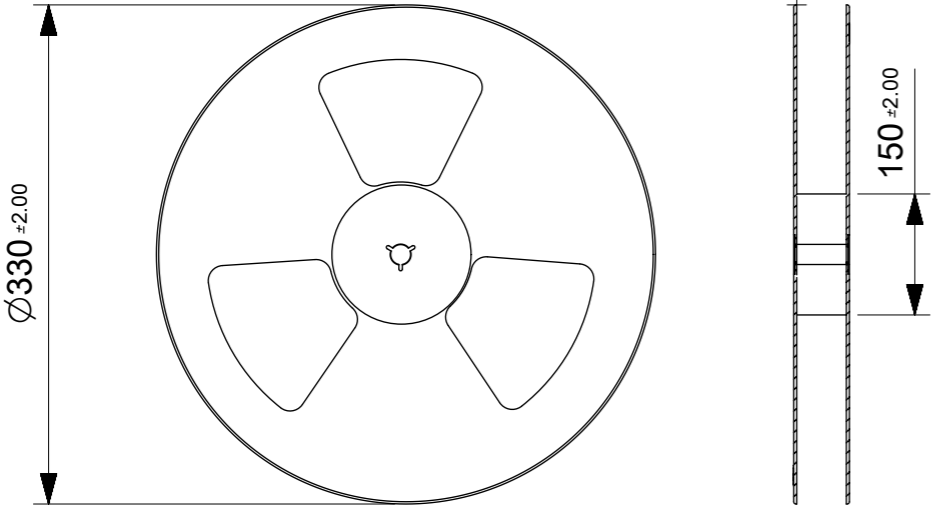
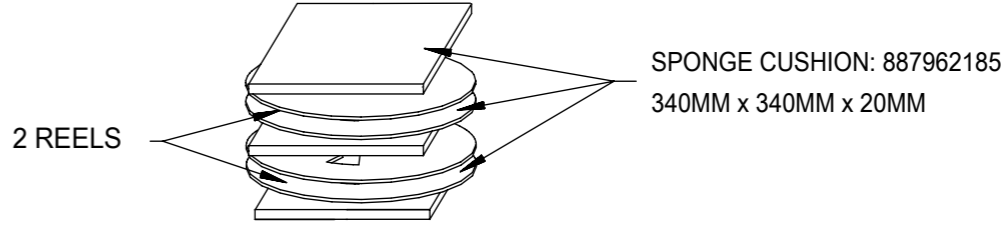
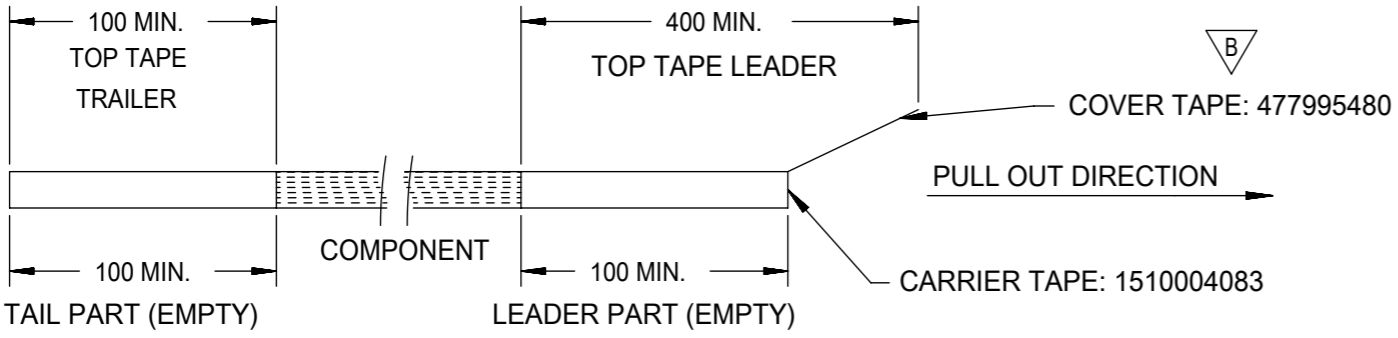

PLASTIC REEL (BLACK):
477995358 (WITH EMPTY CARRIER IN)

- NOTES:
1. PACKING REELS INTO CARTON ACCORDINGLY TO THE ILLUSTRATION AS SHOWN;
 2. PARTIAL PACKAGING SHOULD BE AVOIDED;
 3. PACKAGING SPECIFICATION IS BASED ON GENERAL PACKAGING ONLY. IT MAY BE CHANGED BASED ON THE RESULT OF DROP TEST.

THIS DRAWING CONTAINS INFORMATION THAT IS PROPRIETARY TO MOLEX ELECTRONIC TECHNOLOGIES, LLC AND SHOULD NOT BE USED WITHOUT WRITTEN PERMISSION											
QUALITY SYMBOLS ▽A = 0 ▽E = 0 ▽F = 0 ▼ = 0 ▽C = 0 ⊗ = 0 ■ = 0 ▽ = 0	EC NO: 116744 DRWN: FCHEN11 CHK'D: APPR: AYIN	2017/05/10 2017/05/26	GENERAL TOLERANCES (UNLESS SPECIFIED)		DIMENSION UNITS	SCALE					
			ANGULAR TOL ± °		MM	1:1					
			4 PLACES ±		DRWN BY	DATE	PACKAGING SPECIFICATION FOR 1.40MM HEIGHT MICRO SD CONNECTOR				
			3 PLACES ±		XQZHANG	2016/04/13					
			2 PLACES ±		CHK'D BY	DATE	PACKAGING DESIGN DRAWING				
1 PLACE ±		CHKD BY									
0 PLACES ±		APPR BY	DATE	SERIES	MATERIAL NUMBER	CUSTOMER					
				151129	1511290001	GENERAL MARKET					
				DRAWING SIZE		THIRD ANGLE PROJECTION	DOCUMENT NUMBER		DOC TYPE	DOC PART	SHEET NUMBER
				A3			PK-151129-0001	PDD	000	1 OF 1	

RELEASE STATUS	RELEASE DATE
----------------	--------------