

LTC3576EUFE-1
**Switching Power Manager + USB On-the-Go
 + OVP + HV Buck VC Control + 3 Bucks**
DESCRIPTION

Demonstration Circuit DC1577A is a Switching Power Manager with USB On-the-Go + Triple Step Down DC/DCs. The LTC3576EUFE-1 is available in a 38-pin (4mm × 6mm) QFN surface mount package.

LTC, LTM, LT, Burst Mode, OPTI-LOOP, Over-The-Top and PolyPhase are registered trademarks of Linear Technology Corporation. Adaptive Power, C-Load, DirectSense, Easy Drive, FilterCAD, Hot Swap, LinearView, µModule, Micropower SwitcherCAD, Multimode Dimming, No Latency ΔΣ, No Latency Delta-Sigma, No R_{SENSE}, Operational Filter, PanelProtect, PowerPath, PowerSOT, SmartStart, SoftSpan, Stage Shedding, SwitcherCAD, ThinSOT, UltraFast and VLDO are trademarks of Linear Technology Corporation. Other product names may be trademarks of the companies that manufacture the products.

PERFORMANCE SUMMARY Specifications are at T_A = 25°C

SYMBOL	PARAMETER	CONDITIONS	MIN	TYP	MAX	UNITS
V _{USB}	VUSB Input Voltage Range	Input disabled from 6V–30V	4.35		30	V
V _{OUT}	V _{OUT} Output Voltage Range	Range is mode and load dependant	3.5		5.5	V
V _{BAT}	Output Float Voltage	Constant voltage mode		4.1		V
I _{BAT}	Output Charge Current	Constant current mode		0.5	1	A

SOFTWARE GUI

The DC1577A Demo Circuit can be controlled from a software GUI. Most of the features of the LTC3576EUFE-1 are only accessible via the I²C channel. When the QuikEval program is active and a DC590 with a DC1577A connected and attached to the USB cable, the “LTC3576” form should automatically pop up and be fully operational:

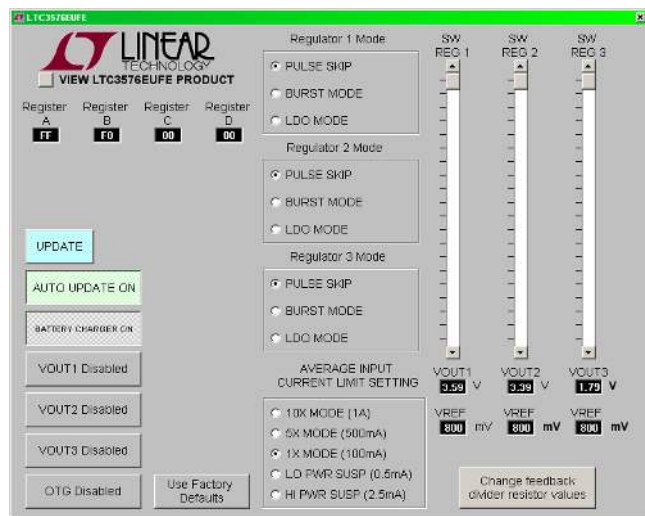

Figure 1. GUI control panel

SOFTWARE OPERATION

The software GUI automatically opens the control panel shown above. This control panel allows control of most major functions of the LTC3576EUFE-1. The EN1, EN2, EN3, and ENOTG signals are wire OR’ed with individual regulator enable regulator signals from the I²C channel. Consequent to this, if the EN_x or ENOTG signals are high, the regulators will be enabled regardless of the state of the I²C channel regulator control bits.

Register A, B, C and D display

These are not writeable and are provided as a programming aid. The current value of the I²C A, B, C and D registers are displayed.

Update button

Forces an immediate update of the I²C registers.

Autoupdate button

LTC3576EUFE-1

If enabled (default) will update the I2C channel whenever something is changed.

Battery charger button

If on (default) the battery charger in the LTC3576EUFE-1 will be enabled, and if off the battery charger will be disabled.

VOUT1~VOUT3 buttons

Individually enable or disable the three voltage regulators. These only function if the ENx pins are held low.

Switchmode Regulators mode

Set the mode of operation of all the switchmode regulators.

VOUT1, VOUT2 and VOUT3 sliders

Allow control of voltage regulator 1, 2 and 3 output voltages by adjusting the respective reference DACs.

VOUT1~3 output and reference voltages

These are not writeable, but reflect the current state of the reference DACs, and feedback resistors.

Input current limit

Set the maximum power drawn from the USB port.

Change feedback divider resistor values

This opens the form:

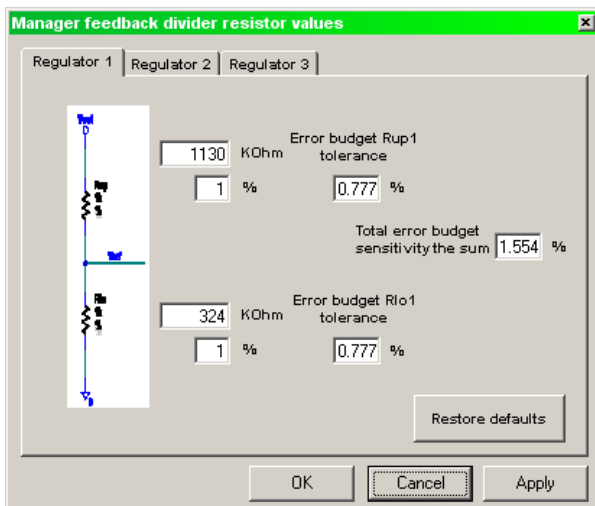

Figure 2. Feedback resistor control panel

This form allows the feedback resistor divider network on each regulator to be changed. The information changed here, is saved, and is durable from session to session. However, the factory values can be recovered by pressing the “Restore defaults” button

QUICK START PROCEDURE

Using short twisted pair leads for any power connections, with all loads and power supplies off, refer to Figures 2 & 3 for the proper measurement and equipment setup.

A companion HV Buck demo board is required for this check out procedure. The DC1394 (LT3480) board is recommended, and will be used for the following procedure. Please refer to the DC1394 Quick Start Guide for further information.

Follow the procedure below:

1. Set “DVCC” jumper (JP9) to “MODE”, JP7 & JP8 to “0”. Do not start the GUI, at this time, as JP9 has disabled the I²C interface.
2. Set PS1 to 5V, and PS4 to 3.6V. Observe that $3.55V < V_{OUT} (VM6) < 3.70V$ and $80mA < I(V_{USB}) (AM1) < 95mA$. The USB current limit is set for 1X (100mA), and the battery charger is set to 500mA. So, V_{OUT} collapses until the charge current matches the current available from the USB input.
3. Set ILIM1 (JP2) and ILIM0 (JP1) to “1”. Observe that $3.80 < V_{OUT} (VM4) < 4.10V$ and $380mA < I(V_{USB}) < 420mA (AM1)$. The USB input current limit is now 5X (500mA), and the V_{OUT} switching regulator behaves like a transformer, exchanging output current for output voltage. So, the input current is $\approx (V_{OUT}/V_{USB}) * 500mA$. Set Load 1 to 0A.
4. Set ILIM1 (JP2) to “0” and ILIM0 (JP1) to “1”. Set Load 1 to 500mA. Observe $4.00V < V_{OUT} < 4.15V (VM4)$ and $760mA < I(V_{USB}) < 840mA (AM1)$. The USB input current limit is now 10X (1A).
5. Set “DVCC” Jumper (JP9) to “DVCC”, JP7 and JP8 to “DC590”. Start the GUI
6. Set PS1 to 5V, and PS4 to 3.6V. . Observe that $3.55V < V_{OUT} (VM6) < 3.70V$ and $80mA < I(V_{USB}) (AM1) < 95mA$. The USB current limit is set for 1X (100mA), and the battery charger is set to 500mA. So, V_{OUT} collapses until the charge current matches the current available from the USB input.
7. Use GUI to set “Average input current limit setting” to “5X Mode (500mA). . Observe that $3.55V < V_{OUT} (VM6) < 3.70V$ and $80mA < I(V_{USB}) (AM1) < 95mA$. The USB current limit is set for 1X (100mA), and the battery charger is set to 500mA. So, V_{OUT} collapses until the charge current matches the current available from the USB input.
8. Use GUI to set “Average input current limit setting” to “10X Mode (1A). Set Load 1 to 500mA. Observe $4.00V < V_{OUT} < 4.15V (VM4)$ and $760mA < I(V_{USB}) < 840mA (AM1)$. The USB input current limit is now 10X (1A).
9. Set PS1 to 0V, and Load 1 to 0A. Observe that $3.50V < V_{OUT} 3.65V (VM6)$ and $V(V_{OUT}, BAT) < 30mV (VM6 - VM7)$. The ideal diode is now on, with a minimal load on V_{OUT}.
10. Set Load 1 to 1A. Observe that $3.50V < V_{OUT} (VM6) < 3.60V$ and $V(V_{OUT},BAT) < 0.10V (VM6 - VM7)$. Set Load 1 to 0A. The ideal diode is on and supplying the 1A Load 1 load from the battery.
11. Set NTC (JP4) to “EXT”. Does the “Battery Charging” LED blink? Set NTC (JP4) to “INT”.
12. Set WALL (DC1394, JP3) to “HVBUCK”, COMP (DC1394, JP2) to “REMOTE”, and SYNC (DC1394, JP1) to “RUN/SYNC”. Increase PS2 from 0V to 8V. Observe that $3.80V < V_{OUT} < 4.10V (VM6)$ and $0.98V < V(PROG) < 1.02V (VM5)$. The HV Buck regulator is now providing power to V_{OUT}, and the internal regulator has stopped supplying power from the USB port.
13. Set Load 1 to 1A. Observe that $3.80V < V_{OUT} < 4.10V (VM6)$ and $0.98V < V(PROG) < 1.02V (VM5)$.

LTC3576EUFE-1

14. Set PS2 to 38V. Measure VOUT (VM6) and V (PROG) (VM5). Observe that $3.80V < VOUT < 4.10V$ (VM6) and $0.98V < V (PROG) < 1.02V$ (VM5).
15. Set WALL (DC1394, JP3) to “5V ADAPTOR” and PS3 to 5V. Observe that $4.40V < VOUT < 5.40V$ (VM6) and $0.98V < V (PROG) < 1.02V$ (VM5). The 5V adaptor is now providing the power VOUT. The voltage of PS3 will not track V (BAT) and the dissipation in the charger will increase.
16. Set Load 1 to 1A. Observe that $4.40V < VOUT < 5.40V$ (VM6) and $0.98V < V (PROG) < 1.02V$ (VM5). Set Load 1 to 0A and set Wall (DC1394, JP3) to “HVBUCK”.
17. Use GUI to enable VOUT1, VOUT2, and VOUT3. Observe that $3.48V < VOUT1 < 3.70V$ (VM10), $3.28V < VOUT2 < 3.49V$ (VM8), and $1.74V < VOUT3 < 1.84V$ (VM9).
18. Set Load 2 to 400mA, Load 3 to 1A, and Load 4 to 400mA. Observe that $3.48V < VOUT1 < 3.70V$ (VM10), $3.28V < VOUT2 < 3.49V$ (VM8), and $1.74V < VOUT3 < 1.84V$ (VM9).
19. Use GUI to set VOUT1, VOUT2, and VOUT3 to minimum. Observe that $1.85V < VOUT1 < 1.96V$ (VM10), $1.74V < VOUT2 < 1.85V$ (VM8), and $0.93V < VOUT3 < 0.977V$ (VM9).
20. Set Load 2 to 0mA, Load 3 to 0mA, and Load 4 to 400mA. Observe that $1.85V < VOUT1 < 1.96V$ (VM10), $1.74V < VOUT2 < 1.85V$ (VM8), and $0.93V < VOUT3 < 0.977V$ (VM9).
21. Use the GUI to disable VOUT1, VOUT2, and VOUT3. Observe that $VOUT1 < 0.1V$ (VM10), $VOUT2 < 0.1V$ (VM8), and $VOUT3 < 0.1V$ (VM9).

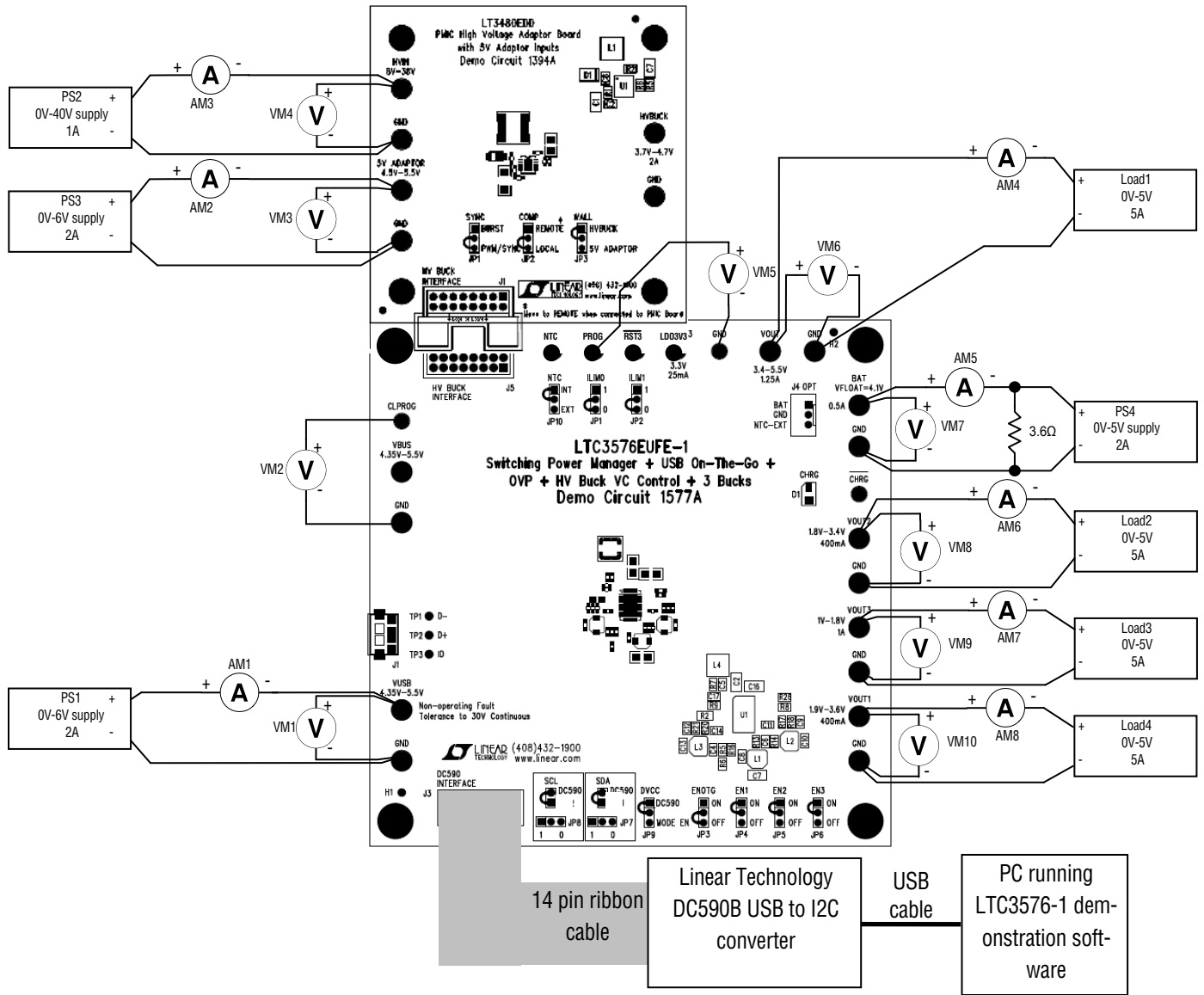

Note: All connections from equipment should be Kelvin connected directly to the Board PINS which they are connected to on this diagram and any input, or output, leads should be twisted pair

Figure 3. Proper Measurement Equipment Setup for DC1577A

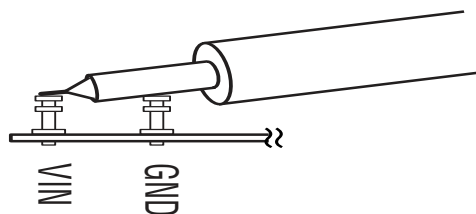
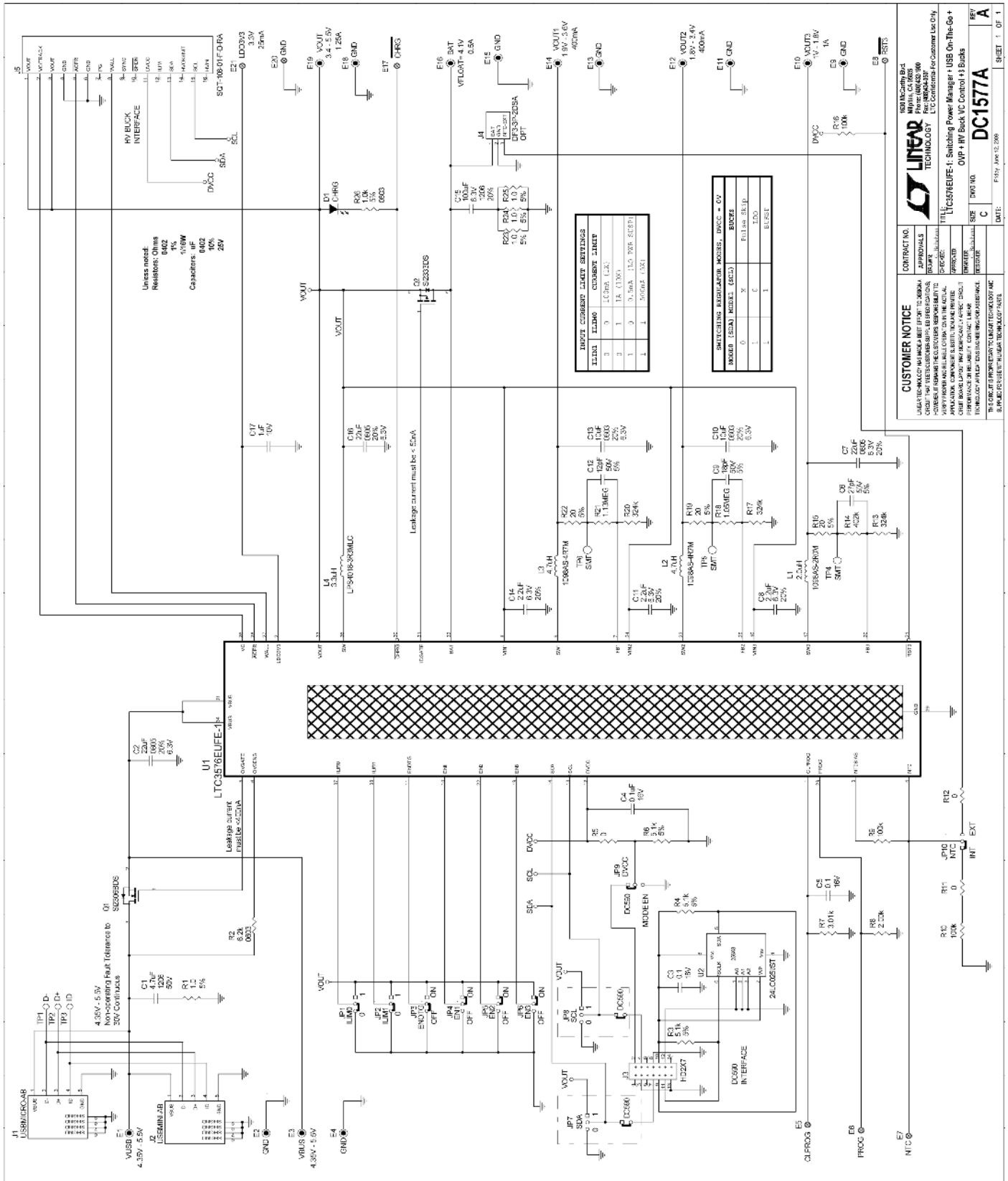

Figure 4. Measuring Input or Output Ripple

LTC3576EUF-1



CUSTOMER NOTICE
LINEAR TECHNOLOGY HAS MADE BEST EFFORT TO DESIGN AND MANUFACTURE THIS PRODUCT TO MEET THE SPECIFICATIONS AND REQUIREMENTS OF THE CUSTOMER. LINEAR TECHNOLOGY DOES NOT WARRANT, REPRESENT OR GUARANTEE THE PERFORMANCE OF THIS PRODUCT IN ANY APPLICATION. CUSTOMER SHALL BE RESPONSIBLE FOR THE PROPER DESIGN AND USE OF THIS PRODUCT IN THEIR APPLICATION. LINEAR TECHNOLOGY SHALL NOT BE RESPONSIBLE FOR ANY DAMAGE TO OR LOSS OF DATA OR EQUIPMENT RESULTING FROM THE USE OF THIS PRODUCT.

CONTRACT NO.: 0000000000
APPROVALS: 0000000000
DESIGNER: 0000000000
DATE: 0000000000

LINEAR TECHNOLOGY
100 GARDEN STREET, FRAMINGHAM, MA 01901
TEL: 508-875-5200 FAX: 508-875-5201
WWW.LINEARTECH.COM

DC1577A
REV: A
DATE: 0000000000

Figure 5. DC1577A Schematic

Qty	Reference	Part Description	Manufacture / Part #	
REQUIRED CIRCUIT COMPONENTS:				
1	3	C2, C7, C16	CAP, CHIP, X5R, 22 μ F, \pm 20%, 6.3V, 0805	TAIYO-YUDEN, JMK212BJ226MG
2	1	C5	CAP, CHIP, X7R, 0.1 μ F, \pm 10%, 16V, 0402	MURATA, GRM155R71C104KA88
3	1	C6	CAP, CHIP, COG, 27pF, 5%, 50V, 0402	VISHAY, VJ0402A270JXAA
4	3	C8, C11, C14	CAP, CHIP, X5R, 2.2 μ F, 20%, 6.3V, 0402	MURATA, GRM155R60J225ME15D
5	1	C9	CAP, CHIP, COG, 18pF, 5%, 50V, 0402	VISHAY, VJ0402A180JXAA
6	2	C10, C13	CAP, CHIP, X5R, 10 μ F, 10%, 6.3V, 0603	TDK, C1608X5R0J106K
7	1	C12	CAP, CHIP, COG, 12pF, 50V, 5%, 0402	VISHAY, VJ0402A120JXAA
8	1	C17	CAP, CHIP, X5R, 1.0 μ F, 10%, 10V, 0402	TDK, C1005X5R1A105K
9	1	L1	IND, SMT, 2.0 μ H, \pm 20%, 1.9A, 3.0mmX3.2mm	TOKO, 1098AS-2R0M
10	2	L2, L3	IND, SMT, 4.7 μ H, \pm 20%, 1.3A, 3.0mmX3.2mm	TOKO, 1098AS-4R7M
11	1	L4	IND, SMT, 3.3 μ H, \pm 20%, 2.2A, 4.0mmX4.0mm	COILCRAFT, LPS4018-3R3MLC
12	1	Q1	MOSFET, 30V, 65m Ω , 3.5A, SOT-23	VISHAY, Si2306BDS
13	1	R2	RES, CHIP, 6.2k Ω , 1/10W, 5%, 0603	VISHAY, CRCW06036K20JNED
14	1	R7	RES, CHIP, 3.01k Ω , 1/16W, 1%, 0402	VISHAY, CRCW04023K01FKED
15	1	R8	RES, CHIP, 2.00k Ω , 1/16W, 1%, 0402	VISHAY, CRCW04022K00FKED
16	3	R13, R17, R20	RES, CHIP, 324k Ω , 1/16W, 1%, 0402	VISHAY, CRCW0402324KFKED
17	1	R14	RES, CHIP, 402k Ω , 1/16W, 1%, 0402	VISHAY, CRCW0402402KFKED
18	1	R18	RES, CHIP, 1.05MEG Ω , 1/16W, 1%, 0402	VISHAY, CRCW04021M05FKED
19	1	R21	RES, CHIP, 1.13MEG Ω , 1/16W, 1%, 0402	VISHAY, CRCW04021M13FKED
20	1	U1	Switching Power Manager with USB On-the-Go + Triple Step-Down DC/DCs	LINEAR TECH., LTC3576EUFE-1
ADDITIONAL DEMO BOARD CIRCUIT COMPONENTS:				
1	1	C1	CAP, CHIP, X7R, 4.7 μ F, \pm 10%, 50V, 1206	MURATA, GRM31CR71H475KA12L
2	2	C3, C4	CAP, CHIP, X7R, 0.1 μ F, \pm 10%, 16V, 0402	MURATA, GRM155R71C104KA88
3	1	C15	CAP, CHIP, X5R, 100 μ F, \pm 20%, 6.3V, 1206	MURATA, GRM31CR60J107ME39L
4	1	D1	LED, SMT, GREEN, 1206	PANASONIC, LN1351CTR
5	1	Q2	MOSFET, -12V, 35m Ω , -5.3A, SOT-23	VISHAY, Si2333DS
6	4	R1, R23, R24, R25	RES, CHIP, 1.0 Ω , 1/16W, 5%, 0402	VISHAY, CRCW04021R00JNED
7	3	R3, R4, R6	RES, CHIP, 5.1k Ω , 5%, 1/16W, 0402	VISHAY, CRCW04025K10JNED
8	3	R5, R11, R12	RES, CHIP, 0 Ω , 1/16W, 0402	VISHAY, CRCW04020000Z0ED
9	3	R9, R10, R16	RES, CHIP, 100k Ω , 1/16W, 1%, 0402	VISHAY, CRCW0402100KFKED
10	3	R15, R19, R22	RES, CHIP, 20 Ω , 1/16W, 5%, 0402	VISHAY, CRCW040220R0JNED
11	1	R26	RES, CHIP, 1.0k Ω , 5%, 1/10W, 0603	VISHAY, CRCW06031K00JNED
12	1	U2	I2C EEPROM	MICROCHIP, 24LC025-I/ST
HARDWARE FOR DEMO BOARD ONLY:				
1	14	E1, E2, E3, E4, E9, E10, E11, E12, E13, E14, E15, E16, E18, E19	Turret, 0.09"	MILL-MAX, 2501-2
2	7	E5, E6, E7, E8, E17, E20, E21	Turret, 0.061"	MILL-MAX, 2308-2
3	1	J1	CONN, USB MICRO-A/B	HIROSE, ZX62-AB-5PA
4	1	J2	CONN, USB MINI-A/B	MOLEX, 56579-0576
5	1	J3	CONN, I2C header	MOLEX, 87831-1420
6	0	J4-OPT	CONN, Battery	HIROSE, DF3-3P-2DSA
	1	J5	CONN, HV interface	SAMTEC, SQT-108-01-F-D-RA
7	10	JP1, JP2, JP3, JP4, JP5, JP6, JP7, JP8, JP9, JP10	3 Pin Jumper, 2mm	SAMTEC, TMM-103-02-L-S
8	10	JP1, JP2, JP3, JP4, JP5, JP6, JP7, JP8, JP9, JP10	2mm SHUNT	SAMTEC, 2SN-BK-G
9	2	JP11, JP12	2 Pin Jumper, 2mm	SAMTEC, TMM-102-02-L-S
10	4		STAND-OFF, NYLON 0.375" tall (SNAP ON)	KEYSTONE, 8832 (SNAP ON)

Figure 6. DC1577A BOM