

- Reinforced I/O-isolation 5000 VAC rated for 1000 VAC working voltage
- Ultra-high isolation peak voltage 9000 VDC (1s)
- Common Mode Transient Immunity (dv/dt) 15 kV/μs
- Operating temperature range -40 to +90°C
- Low no-load power consumption 96 – 192 mW
- Internal EN 55032 class A filter
- High efficiency up to 87%
- 2:1 input voltage range: 4.5-9, 9-18, 18-36, 36-75 VDC
- Protection against overload, overvoltage and short circuit
- 3-year product warranty



The new TRI 3 is a high isolation, regulated 3.5 Watt DC/DC converter series which comes in a compact DIP-24 package. The core characteristic of the TRI 3 series is a sophisticated reinforced isolation system which is able to withstand high test voltages (9000 VDC for 1s and 5000 VAC for 60s) and working voltages (1000 VACrms). Complementing this isolation characteristic is a high Common Mode Transient Immunity of 15 kV/μs. The new design allows to fully integrate an EN 55032 class A filter and greatly reduces the no-load power consumption. High efficiencies up to 87% allow safe operation from -40°C to +90°C without derating. All models have a wide 2:1 input voltage range and precisely regulated, isolated output voltages. With the latest IT safety certifications (IEC/EN/UL 62368-1) the TRI 3 series is the perfect choice for many demanding applications in the industrial, transportation and instrumentation sectors.

### Models

Order Code	Input Voltage Range	Output 1		Output 2		Efficiency typ.
		Vnom	I <sub>max</sub>	Vnom	I <sub>max</sub>	
TRI 3-0511	4.5 - 9 VDC (5 VDC nom.)	5 VDC	700 mA			82 %
TRI 3-0512		12 VDC	290 mA			83 %
TRI 3-0513		15 VDC	235 mA			84 %
TRI 3-0515		24 VDC	146 mA			83 %
TRI 3-0522		+12 VDC	145 mA	-12 VDC	145 mA	84 %
TRI 3-0523		+15 VDC	115 mA	-15 VDC	115 mA	84 %
TRI 3-1211	9 - 18 VDC (12 VDC nom.)	5 VDC	700 mA			82 %
TRI 3-1212		12 VDC	290 mA			86 %
TRI 3-1213		15 VDC	235 mA			87 %
TRI 3-1215		24 VDC	146 mA			86 %
TRI 3-1222		+12 VDC	145 mA	-12 VDC	145 mA	87 %
TRI 3-1223		+15 VDC	115 mA	-15 VDC	115 mA	87 %
TRI 3-2411	18 - 36 VDC (24 VDC nom.)	5 VDC	700 mA			82 %
TRI 3-2412		12 VDC	290 mA			85 %
TRI 3-2413		15 VDC	235 mA			87 %
TRI 3-2415		24 VDC	146 mA			86 %
TRI 3-2422		+12 VDC	145 mA	-12 VDC	145 mA	87 %
TRI 3-2423		+15 VDC	115 mA	-15 VDC	115 mA	86 %
TRI 3-4811	36 - 75 VDC (48 VDC nom.)	5 VDC	700 mA			82 %
TRI 3-4812		12 VDC	290 mA			85 %
TRI 3-4813		15 VDC	235 mA			85 %
TRI 3-4815		24 VDC	146 mA			83 %
TRI 3-4822		+12 VDC	145 mA	-12 VDC	145 mA	84 %
TRI 3-4823		+15 VDC	115 mA	-15 VDC	115 mA	84 %

### Input Specifications

Input Current	- At no load	5 Vin models: <b>30 mA typ.</b> 12 Vin models: <b>10 mA typ.</b> 24 Vin models: <b>6 mA typ.</b> 48 Vin models: <b>4 mA typ.</b>
	- At full load	5 Vin models: <b>838 mA typ.</b> 12 Vin models: <b>339 mA typ.</b> 24 Vin models: <b>170 mA typ.</b> 48 Vin models: <b>87 mA typ.</b>
Surge Voltage		5 Vin models: <b>15 VDC max.</b> (1 s max.) 12 Vin models: <b>25 VDC max.</b> (1 s max.) 24 Vin models: <b>50 VDC max.</b> (1 s max.) 48 Vin models: <b>100 VDC max.</b> (1 s max.)
Under Voltage Lockout		5 Vin models: <b>4 VDC typ.</b> 12 Vin models: <b>8 VDC typ.</b> 24 Vin models: <b>16 VDC typ.</b> 48 Vin models: <b>34 VDC typ.</b>
Recommended Input Fuse		(The need of an external fuse has to be assessed in the final application.)
Input Filter		Internal Pi-Type

### Output Specifications

Voltage Set Accuracy		<b>±1% max.</b>
Regulation	- Input Variation (Vmin - Vmax)	single output models: <b>0.5% max.</b> dual output models: <b>0.5% max.</b>
	- Load Variation (0 - 100%)	single output models: <b>0.5% max.</b> dual output models: <b>0.5% max.</b> (Output 1) <b>0.5% max.</b> (Output 2)
	- Voltage Balance (symmetrical load)	dual output models: <b>2% max.</b>
	- Cross Regulation (25% / 100% asym. load)	dual output models: <b>5% max.</b>
Ripple and Noise	- 20 MHz Bandwidth	<b>70 mVp-p max.</b> (w/ 1 µF MLCC)
Capacitive Load	- single output	5 Vout models: <b>750 µF max.</b> 12 Vout models: <b>130 µF max.</b> 15 Vout models: <b>100 µF max.</b> 24 Vout models: <b>39 µF max.</b>
	- dual output	12 / -12 Vout models: <b>75 / 75 µF max.</b> 15 / -15 Vout models: <b>56 / 56 µF max.</b>
Minimum Load		Not required
Temperature Coefficient		<b>±0.02 %/K max.</b>
Start-up Time		<b>30 ms max.</b>
Short Circuit Protection		Continuous, Automatic recovery
Output Current Limitation		<b>150% typ.</b> of Iout max.
Oversvoltage Protection		<b>125% typ.</b> of Vout nom.
Transient Response	- Response Deviation	<b>5% max.</b> (75% to 100% Load Step)
	- Response Time	<b>300 µs typ.</b> (75% to 100% Load Step)

### Safety Specifications

Safety Standards	- IT / Multimedia Equipment	EN 62368-1 IEC 62368-1 UL 62368-1
	- Certification Documents	<a href="http://www.tracopower.com/overview/tri3">www.tracopower.com/overview/tri3</a>
Pollution Degree		PD 2
Over Voltage Category		OVC II

All specifications valid at nominal voltage, resistive full load and +25°C after warm-up time, unless otherwise stated.

## EMC Specifications

EMI Emissions	- Conducted Emissions	EN 55032 class A (internal filter) EN 55032 class B (with external filter) FCC Part 15 class A (internal filter)
	- Radiated Emissions	EN 55032 class A (with external filter) External filter proposal: <a href="http://www.tracopower.com/overview/tri3">www.tracopower.com/overview/tri3</a>
EMS Immunity	- Electrostatic Discharge	Air: EN 55024 (IT Equipment) EN 61000-4-2, ±15 kV, perf. criteria A
	- RF Electromagnetic Field	Contact: EN 61000-4-2, ±6 kV, perf. criteria A EN 61000-4-3, 10 V/m, perf. criteria A
	- EFT (Burst) / Surge	EN 61000-4-4, ±2 kV, perf. criteria A EN 61000-4-5, ±2 kV, perf. criteria A
	- Conducted RF Disturbances	Ext. input component: 5 Vin models: KY 1000 µF / 35 V // V10P45 12 Vin models: KY 560 µF / 50 V 24 Vin models: KY 470 µF / 50 V 48 Vin models: KY 330 µF / 100 V EN 61000-4-6, 10 Vrms, perf. criteria A
	- PF Magnetic Field	Continuous: EN 61000-4-8, 100 A/m, perf. criteria A

## General Specifications

Relative Humidity		95% max. (non condensing)
Temperature Ranges	- Operating Temperature	-40°C to +96°C
	- Case Temperature	+105°C max.
	- Storage Temperature	-40°C to +125°C
Power Derating	- High Temperature	8.3 %/K above 90°C
		See application note: <a href="http://www.tracopower.com/overview/tri3">www.tracopower.com/overview/tri3</a>
Cooling System		Natural convection (20 LFM)
Altitude During Operation		5'000 m max.
Switching Frequency		330 kHz typ. (PWM)
Insulation System		Reinforced Insulation
Working Voltage (rated)		1'000 VAC
Isolation Test Voltage	- Input to Output, 60 s	5'000 VAC
	- Input to Output, 1 s	9'000 VDC
Isolation Resistance	- Input to Output, 500 VDC	10'000 MΩ min.
Isolation Capacitance	- Input to Output, 100 kHz, 1 V	40 pF max.
Common Mode Transient Immunity		15 kV/µs min.
Reliability	- Calculated MTBF	5'815'000 h (MIL-HDBK-217F, ground benign)
Washing Process		Allowed (hermetical product)
		See Cleaning Guideline: <a href="http://www.tracopower.com/info/cleaning.pdf">www.tracopower.com/info/cleaning.pdf</a>
Housing Material		Plastic (UL 94 V-0 rated)
Potting Material		Silicone (UL 94 V-0 rated)
Pin Material		Copper Alloy (C6801)
Pin Foundation Plating		Nickel (2 - 4 µm)
Pin Surface Plating		Tin (3 - 5 µm), matte
Housing Type		Plastic Case
Mounting Type		PCB Mount
Connection Type		THD (Through-Hole Device)
Footprint Type		DIP24
Soldering Profile		Wave Soldering
		260°C / 10 s max.
Weight		15.5 g

All specifications valid at nominal voltage, resistive full load and +25°C after warm-up time, unless otherwise stated.

Environmental Compliance - REACH Declaration

[www.tracopower.com/info/reach-declaration.pdf](http://www.tracopower.com/info/reach-declaration.pdf)

- RoHS Declaration

REACH SVHC list compliant

REACH Annex XVII compliant

[www.tracopower.com/info/rohs-declaration.pdf](http://www.tracopower.com/info/rohs-declaration.pdf)

Exemptions: 7a

(RoHS exemptions refer to the component concentration only, not to the overall concentration in the product (O5A rule).  
The SCIP number is provided on request.)

### Supporting Documents

[Overview Link](#) (for additional Documents)

[www.tracopower.com/overview/tri3](http://www.tracopower.com/overview/tri3)

### Outline Dimensions

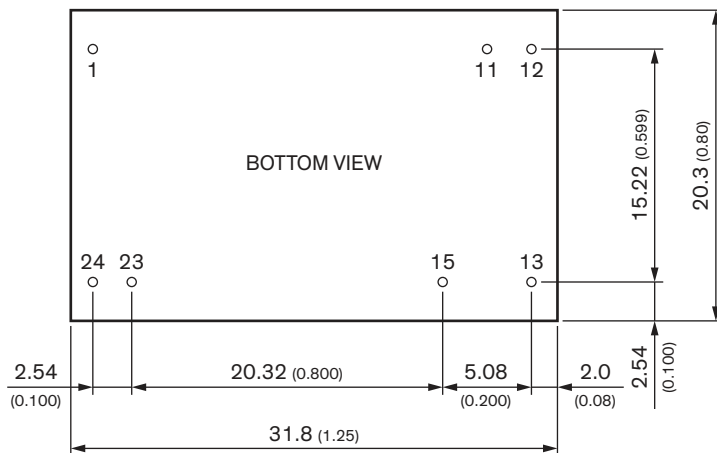
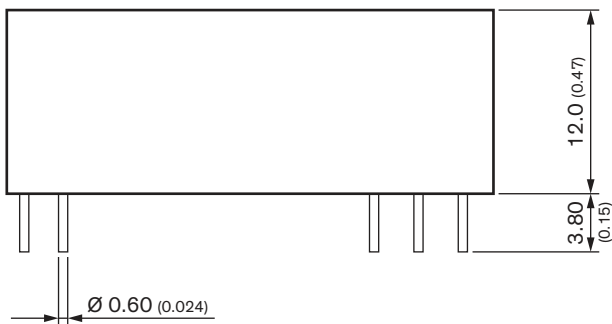

Dimensions in mm (inch)

Tolerances: X.X  $\pm 0.5$  (X.XX  $\pm 0.02$ )

X.XX  $\pm 0.25$  (X.XXX  $\pm 0.01$ )

Pin  $\varnothing 0.6 \pm 0.05$  (0.02  $\pm 0.002$ )

### Pinout

Pin	Single Output	Dual Output
1	+Vin (Vcc)	+Vin (Vcc)
11	No pin	Common
12	-Vout	No pin
13	+Vout	-Vout
15	No pin	+Vout
23	-Vin (GND)	-Vin (GND)
24	-Vin (GND)	-Vin (GND)