

# Surface-mount Power Transistor SSD103

## Absolute Maximum Ratings (Ta=25°C)

Symbol	Ratings	Unit
Vcbo	65±5	V
Vceo	65±5	V
Vebo	6	V
Ic	6	A
Ic (pulse)	10 (Pw≤1mS, Duty≤25%)	A
Ib	10	A
Pc	1.5*1	W
Tj	150	°C
Tstg	-55 to +150	°C

\*1: FR4 70mm×100mm×1.6mm  
(drain heatsink copper foil area 25×25mm)

## Electrical Characteristics (Ta=25°C)

Symbol	Test Conditions	Ratings			Unit
		min	typ	max	
ICBO	V <sub>CB</sub> = 60V, I <sub>E</sub> = 0A			10	A
IEBO	V <sub>EB</sub> = 6V, I <sub>C</sub> = 0A			10	A
VCEO	I <sub>C</sub> = 50mA	60	65	70	V
hFE	V <sub>CE</sub> = 1V, I <sub>C</sub> = 1A	400	800	1500	
VCE (sat)	I <sub>C</sub> = 1.5A, I <sub>B</sub> = 15mA		0.11	0.15	V
VFEC	I <sub>FEC</sub> = 6A		1.25	1.5	V
Es/b	L = 10mH	80			mJ

## External Dimensions SOP8

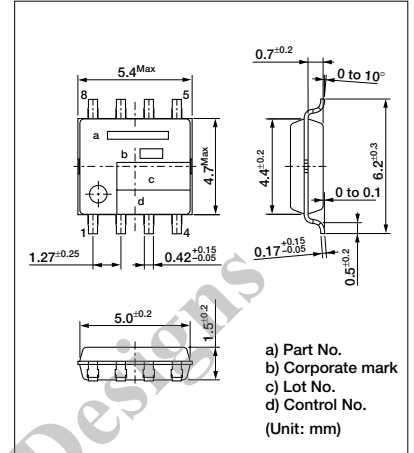

### IC—VCE Characteristics (typ.)

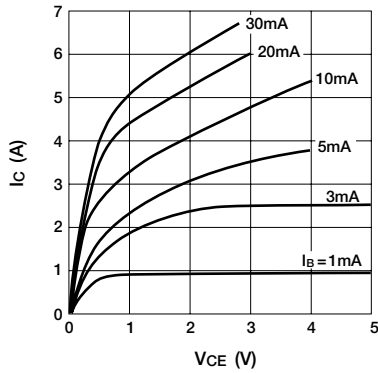

### VCE (sat)—IC Temperature Characteristics (typ.)

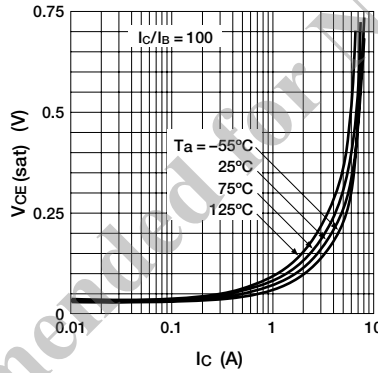

### IC—VBE Temperature Characteristics (typ.)

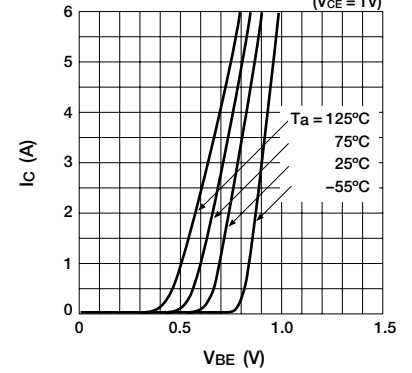

### hFE—IC Temperature Characteristics (typ.)

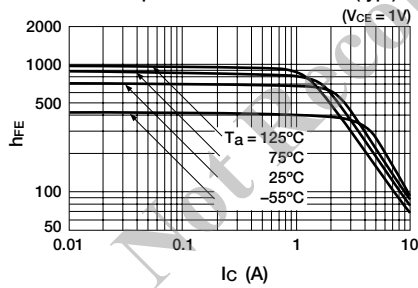

### ton·tstg·tr—IC Characteristics (typ.)

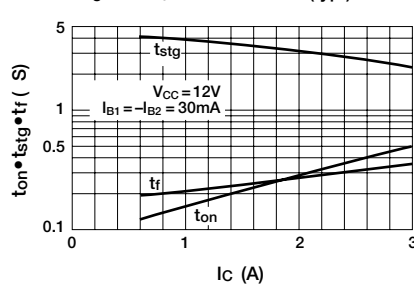

### Safe Operating Area (Single pulse)

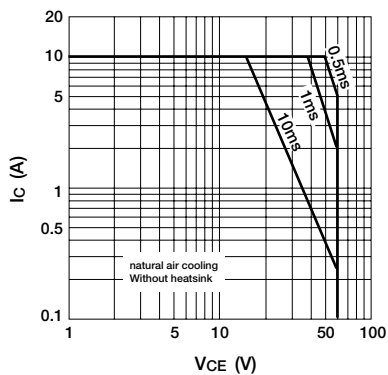

### Equivalent Circuit Diagram

