

J8064D649P

NOTICE: THE INFORMATION AND DESIGN CONTAINED HEREIN IS THE PROPERTY OF PULSE JACK WHO RESERVES ALL RIGHTS THEREON.

FINAL OUTLINE NOTE:

1. CHECK DIMENSIONS PER PACKAGE SPECIFICATION ITEM 7.

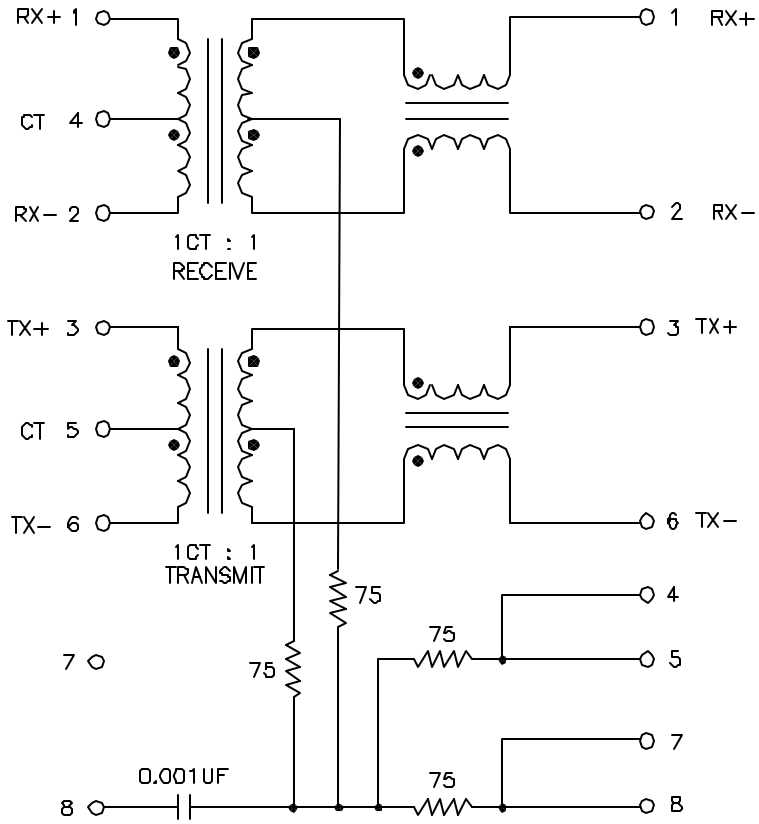

SCHEMATIC

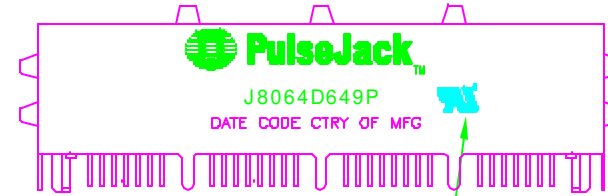

MARK PART WITH "UL MARK" PER MARKING PROCEDURE. MARK POSITION IS OPTIONAL PREFERRED LOCATION IS BACK OF THE PART.

BACK VIEW
FINAL OUTLINE

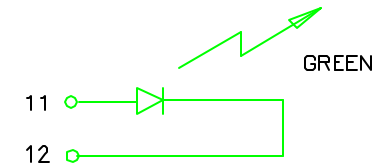
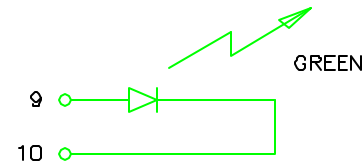

UNLESS OTHERWISE SPECIFIED, ALL DIMENSIONS ARE IN INCHES TOLERANCES ARE:
 DECIMALS .XX ±.01 ANGLES ± 1°
 .XXX ±.005
 DO NOT SCALE DRAWING

SIZE: A301961
 SCALE: NONE

DWG. NO.: J8064D649P
 REV.: 12
 CADD FILE: J8064D649P-7
 SHEET: 7 OF 7

125-J8064

NOTICE: THE INFORMATION AND DESIGN CONTAINED HEREIN IS THE PROPERTY OF PULSE WHO RESERVES ALL RIGHTS THERETO.

TEST NOTES:
UNLESS OTHERWISE SPECIFIED, TESTING IS PERFORMED AT 25°C ±5°C.

1. HIPOT: (100%) WITH PCB PINS (1-8) CONNECTED AND CABLE PINS (1-8) CONNECTED, APPLY 2400 VDC, 2 mA, FOR 9 SECONDS ACROSS PCB PINS AND CABLE PINS. NEED A 1 MOHM RESISTOR IN SERIES WITH THE TEST FIXTURE.
2. CONNECTIVITY: (100%)
 - 2.1 VERIFY FOLLOWING CONTINUITY:
 PCB (1-4) = (2-4) = 1.00 OHMS MAXIMUM.
 PCB (3-5) = (5-6) = 1.00 OHMS MAXIMUM.
 CABLE (1-2) = 2.00 OHMS MAXIMUM.
 CABLE (3-6) = 2.00 OHMS MAXIMUM.
 CABLE (1-3) = (5-8) = (4-7) = 140 TO 160 OHMS
 CABLE (1-4) = 140 TO 160 OHMS
 - 2.2 VERIFY OPENS (RESISTANCE > 10 MEGOHMS)
 PCB (2) TO PCB (3), PCB (6) TO PCB (8)
 PCB (6) TO PCB (7), PCB (7) TO PCB (8)
 - 2.3 CAPACITANCE - PCB 8 TO CABLE 8.
 700 pF MIN. AT 1 KHz, 1 V ON LCR METER.
3. OCL: (100%) 400uH MINIMUM WITH 8 mA DC BIAS AT 100 KHz MEASURE PINS (1-2) AND (3-6) ON CABLE SIDE
4. TURNS RATIO: (100%) TEST AT 100 KHz, 100 mV
 PCB PINS (1-2) / CABLE PINS (1-2) = 1.00 ±2%
 PCB PINS (3-6) / CABLE PINS (3-6) = 1.00 ±2%

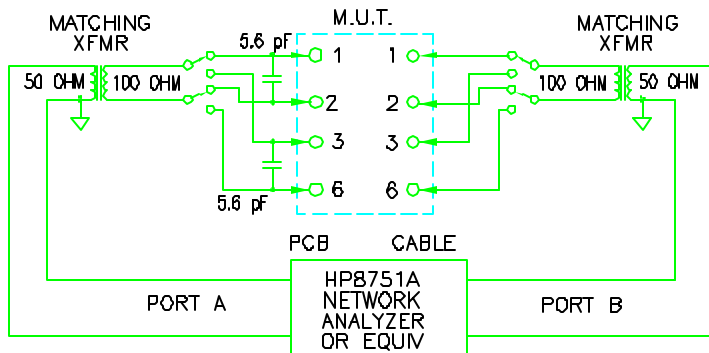

INSERTION LOSS TEST CIRCUIT
FIGURE 7

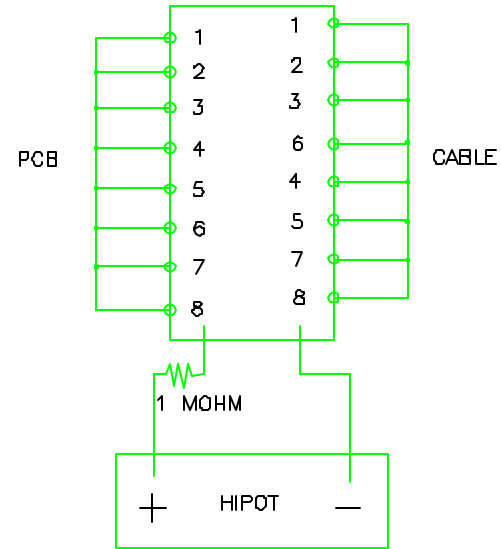

5. INSERTION LOSS: - (100%) FIGURE 7
 CALIBRATE THE NETWORK ANALYZER IN THE S21 MODE BY SHORTING (1-1) AND SHORT (2-2) - DO A THRU CALIBRATION. MEASURE THE INSERTION LOSS BETWEEN 100 KHz AND 200 MHz. THE ATTENUATION SHALL BE WITHIN THE ATTENUATION SHALL BE WITHIN THE FOLLOWING LIMITS ON BOTH CHANNELS.

RECEIVE	
FREQUENCY	ATTENUATION (S21)
1 MHz	-1.0 dB MAX
10 MHz	-1.0 dB MAX
30 MHz	-1.0 dB MAX
65 MHz	-1.0 dB MAX.

TRANSMIT	
FREQUENCY	ATTENUATION (S21)
1 MHz	-1.0 dB MAX
10 MHz	-1.0 dB MAX
30 MHz	-1.0 dB MAX
65 MHz	-1.0 dB MAX.

6. POLARITY: (100%)
 CALIBRATE THE SAME AS IN INSERTION LOSS USING FIGURE 7. PHASE SHALL BE NEGATIVE AND NEAR 0° AT 5 MHz AND APPROACH -90° AT 200 MHz. REVERSED POLARITY IS INDICATED BY +90° PHASE AT 5 MHz.

UNLESS OTHERWISE SPECIFIED, ALL DIMENSIONS ARE IN INCHES
 FRACTIONS ANGLES
 .XX ±.01 ± 1°
 .XXX ±.005
 DO NOT SCALE DRAWING

SIZE PAGE CODE
B01961
 SCALE NONE CADD FILE

DWG. NO.
 125-J8064-6

REV
 18
 SHEET 6 OF 8

NOTICE: THE INFORMATION AND DESIGN CONTAINED HEREIN IS THE PROPERTY OF PULSE WHO RESERVES ALL RIGHTS THEREOF.

TEST NOTES: (CONTINUED)

7. RETURN LOSS: (100%) FIGURE 8
 CALIBRATE THE NETWORK ANALYZER IN THE S11 MODE AND MEASURE THE RETURN LOSS OF BOTH CHANNELS. THE RETURN LOSS SHALL BE WITHIN THE FOLLOWING LIMITS.

FREQUENCY	TRANSMIT/RECEIVE (S11)
1 MHZ	-18 dB MIN
10 MHZ	-18 dB MIN
30 MHZ	-16 dB MIN
60 MHZ	-12 dB MIN
80 MHZ	-12 dB MIN

8. CROSSTALK: (SAMPLE TEST) - FIGURE 9
 CALIBRATE THE NETWORK ANALYZER IN THE S21 MODE BY SHORTING (1-3) AND SHORTING (2-6). DO A THRU CALIBRATION. MEASURE THE CROSSTALK BETWEEN THE TWO CHANNELS OVER THE RANGE OF 1 MHZ TO 100 MHZ. THE CROSSTALK ATTENUATION SHALL BE WITHIN THE FOLLOWING LIMITS:

FREQUENCY	ATTENUATION (S21)
1 MHZ	-40 dB MIN
10 MHZ	-40 dB MIN
32 MHZ	-35 dB MIN
62 MHZ	-35 dB MIN
100 MHZ	-30 dB MIN

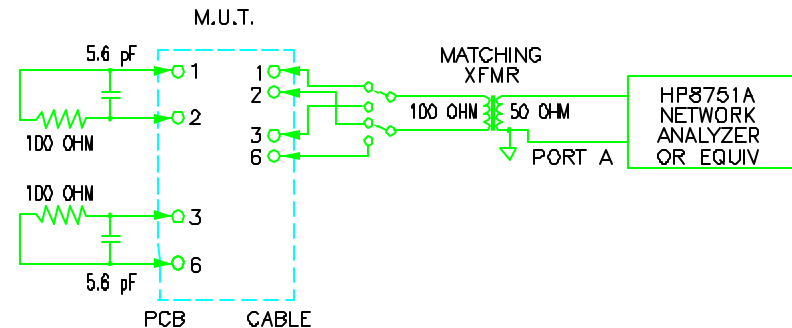

RETURN LOSS TEST CIRCUIT
 FIGURE 8

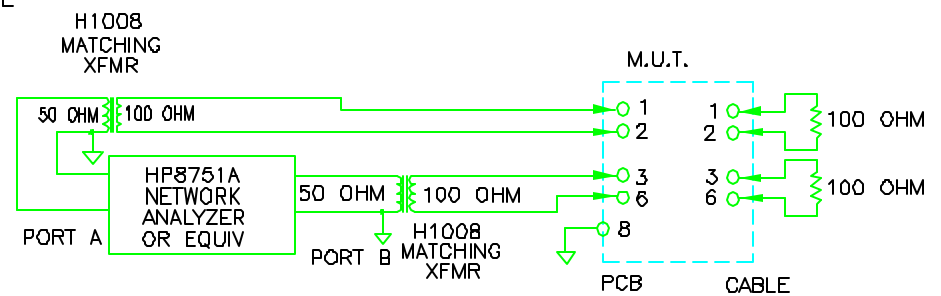

CROSSTALK
 FIGURE 9

UNLESS OTHERWISE SPECIFIED, ALL DIMENSIONS ARE IN INCHES TOLERANCES ARE:
 DECIMALS .XX ±.01 ±.1*
 .XXX ±.005
 DO NOT SCALE DRAWING

PS-2064.001

NOTICE: THE INFORMATION AND DESIGN CONTAINED HEREIN IS THE PROPERTY OF PULSE WHO RESERVES ALL RIGHTS THEREOF.

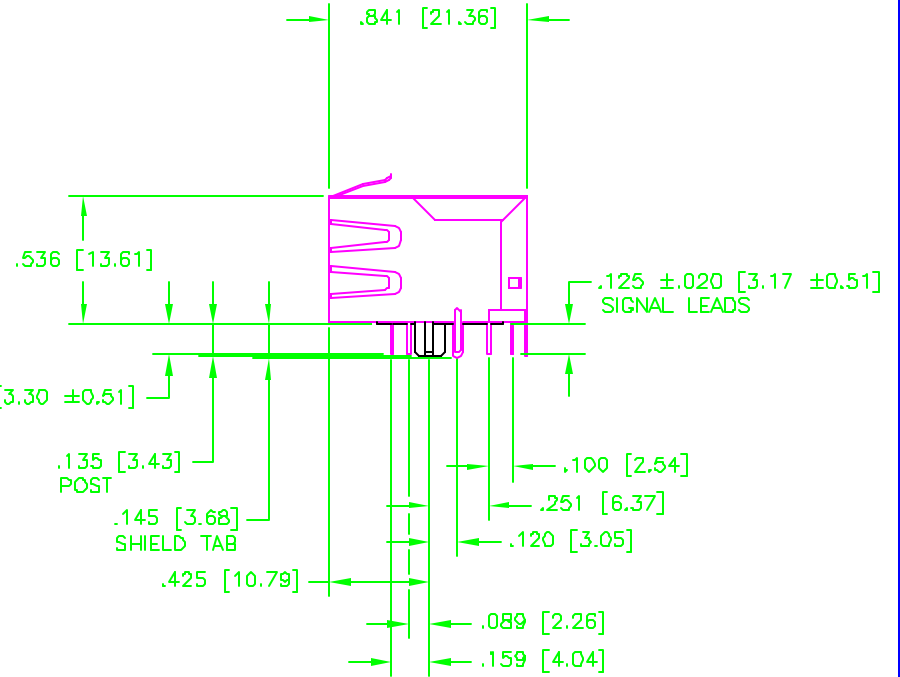
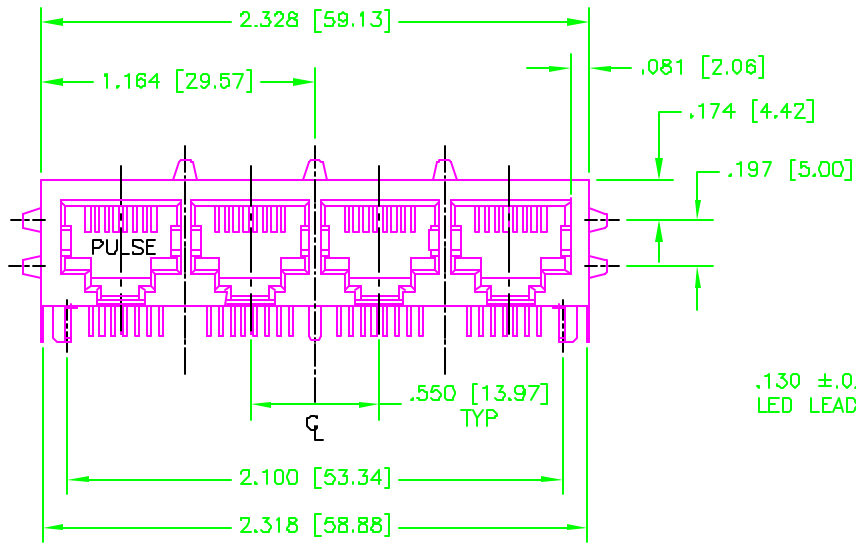

UNLESS OTHERWISE SPECIFIED, ALL DIMENSIONS ARE IN INCHES TOLERANCES AND FINISH:

DECIMALS	± .1*
XX ±.01	3.
XXX ±.005	

DO NOT SCALE DRAWING

SIZE PAGE CODE
B01961

DWG. NO. PS-2064.001

REV G

SCALE 4/1

CADD FILE

PS-2064.001-2

SHEET

2 OF 3

PS-2064.001

NOTICE: THE INFORMATION AND DESIGN CONTAINED HEREIN IS THE PROPERTY OF PULSE WHO RESERVES ALL RIGHTS THEREOF.

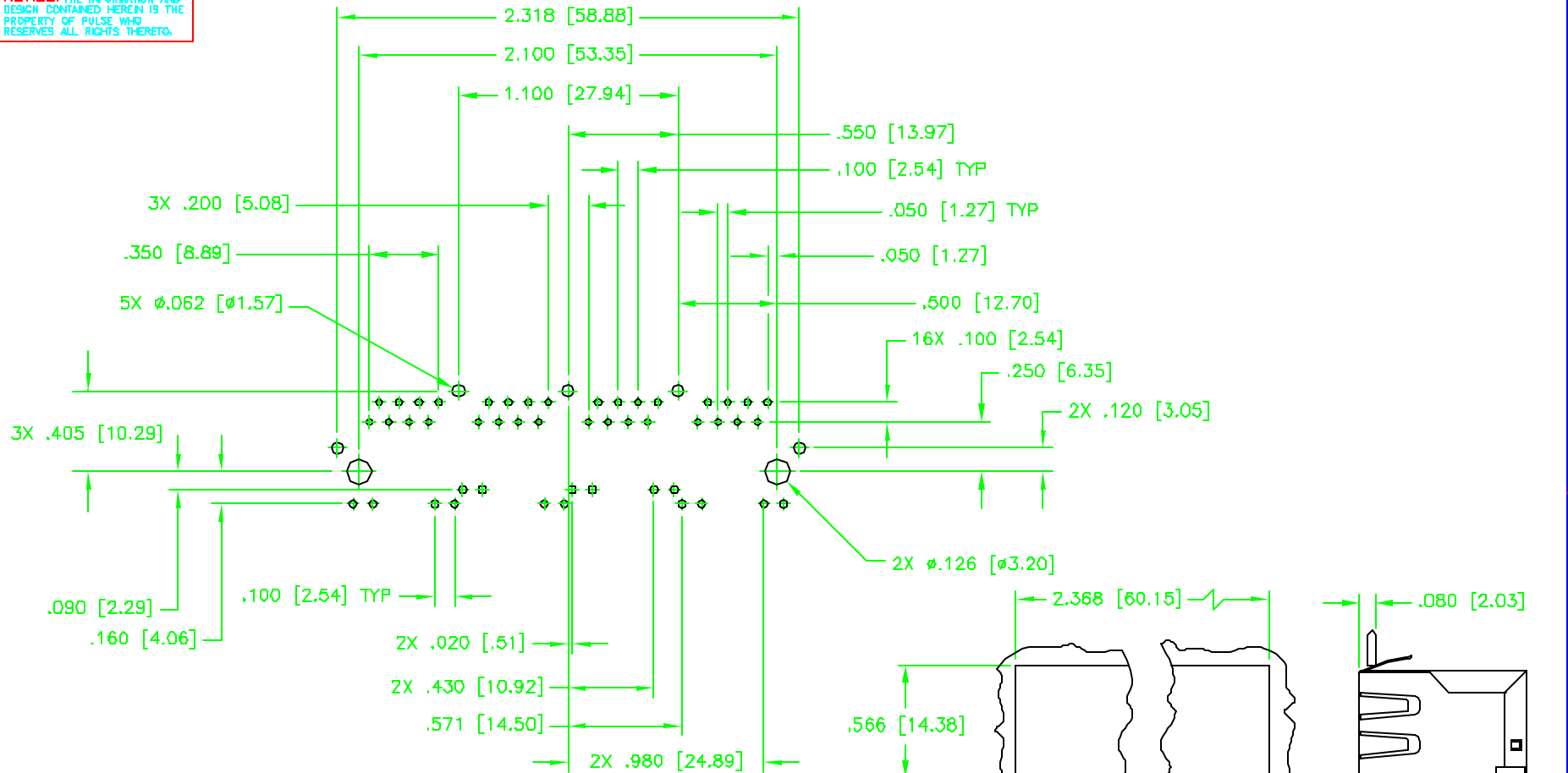

SUGGESTED PRINTED CIRCUIT BOARD LAYOUT
VIEWED FROM COMPONENT SIDE
UNLESS OTHERWISE SPECIFIED PCB DIMENSION ARE ±.003

SUGGESTED PANEL CUTOUT

UNLESS OTHERWISE SPECIFIED ALL DIMENSIONS ARE IN INCHES

DECIMALS ANGLES
 .XX ±.02 ± 1°
 .XXX ±.010

DO NOT SCALE DRAWING

SIZE	DWG. NO.	REV
2/1	B01961	G
SCALE	DWG. FILE	SHEET
2/1	PS-2064.001-3	3 OF 3
PS-2064.001		