

MFG. ENG. APPROVED BY: DATE: QA APPROVED BY: DATE:

PART NO.	NO. OF PINS
W17984-5SG-P-300	5
W17984-6SG-P-300	6
W17984-7SG-P-300	7

NOTES:

1. ALL PARTS ARE BULK PACKED.
2. REFER TO DRAWING HPMCSTD FOR CONTACT PATTERNS.
3. ALL DIMENSIONS ARE REFERENCE ONLY IN INCHES [mm], WITHIN ±0.015 UNLESS OTHERWISE NOTED.

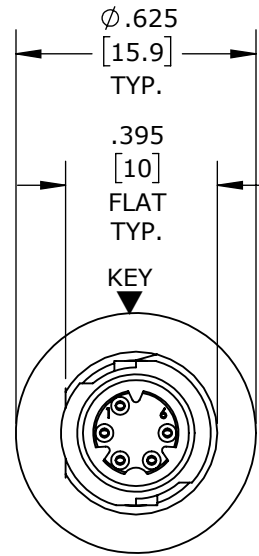

FACE VIEW
W17984-5SG-P-300
5 POSITION
A-KEY

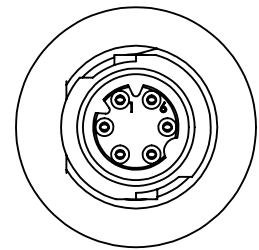

FACE VIEW
W17984-6SG-P-300
6 POSITION
B-KEY

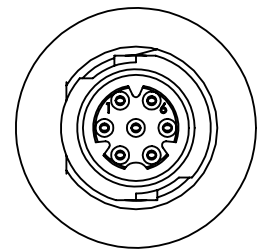

FACE VIEW
W17984-7SG-P-300
7 POSITION
A-KEY

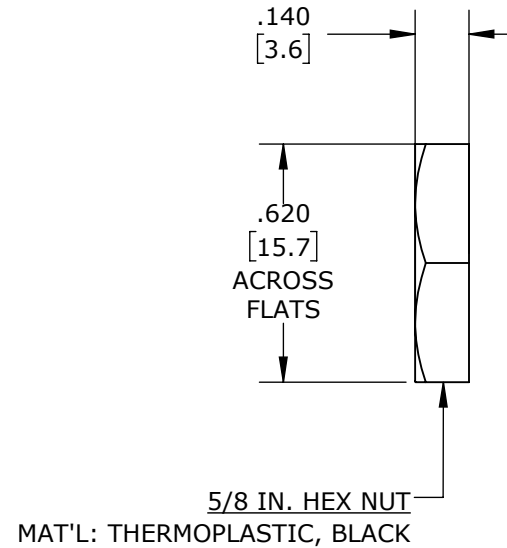

5/8 IN. HEX NUT
MAT'L: THERMOPLASTIC, BLACK

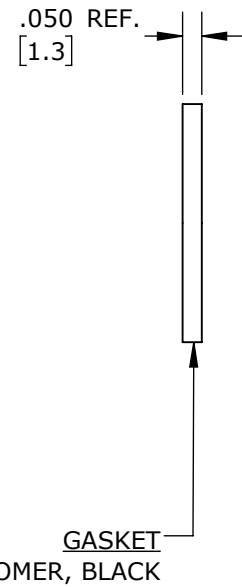

GASKET
MAT'L: ELASTOMER, BLACK

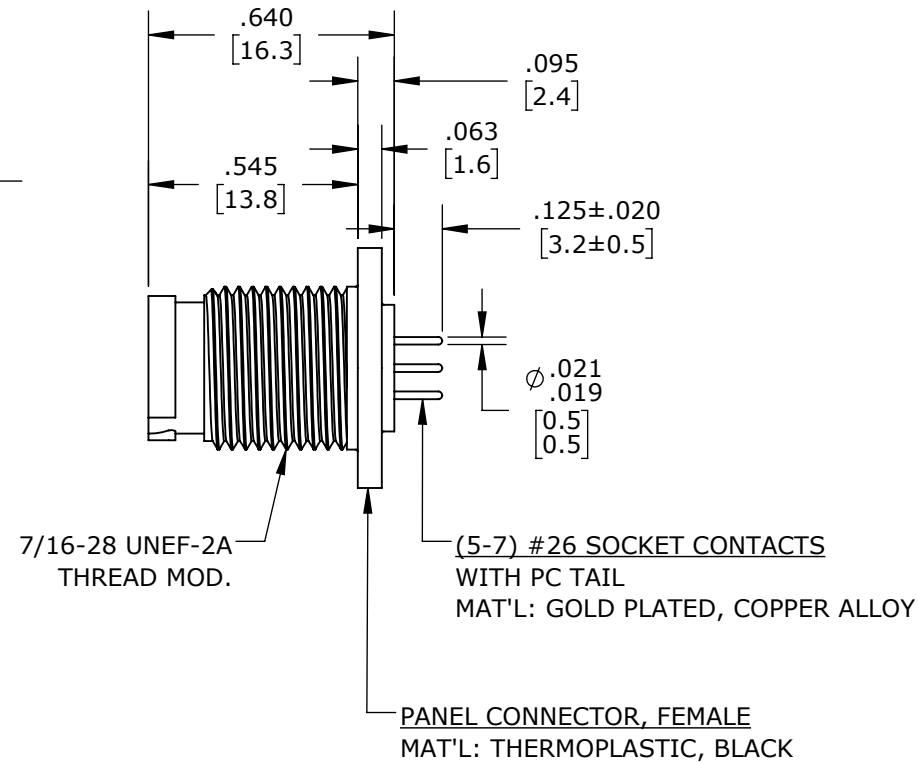

7/16-28 UNEF-2A
THREAD MOD.
(5-7) #26 SOCKET CONTACTS
WITH PC TAIL
MAT'L: GOLD PLATED, COPPER ALLOY
PANEL CONNECTOR, FEMALE
MAT'L: THERMOPLASTIC, BLACK

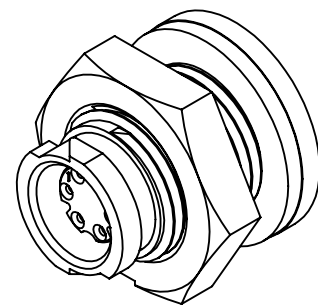

ASSEMBLED VIEW
FOR CUSTOMER REF. ONLY

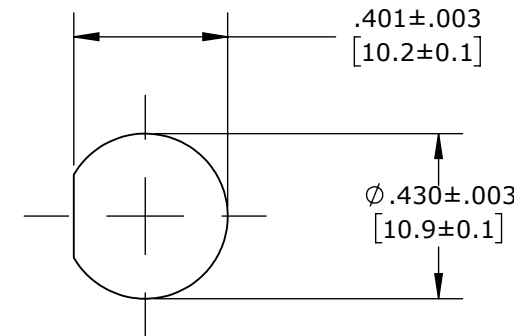

RECOMMENDED PANEL CUTOUT

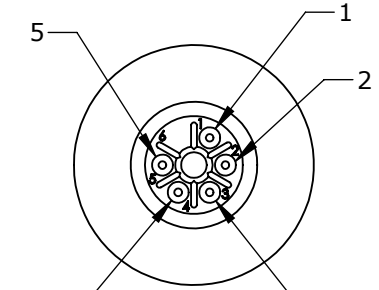

WIRE VIEW
W17984-5SG-P-300

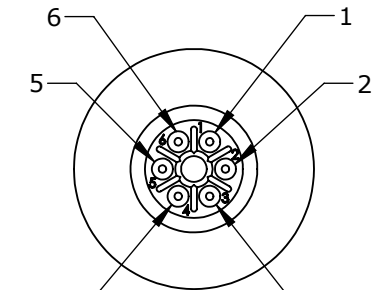

WIRE VIEW
W17984-6SG-P-300

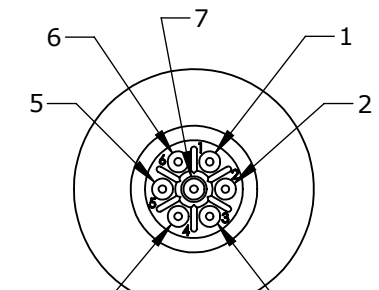

WIRE VIEW
W17984-7SG-P-300

CUSTOMER PRINT

PART NUMBER: W17984-XSG-P-300

CUSTOMER APPROVAL

THIS DOCUMENT CONTAINS CONFIDENTIAL INFORMATION PROPRIETARY TO CONXALL CORPORATION. ANY REPRODUCTION, DISCLOSURE, OR USE OF THIS DOCUMENT /INFORMATION IS EXPRESSLY PROHIBITED UNLESS AUTHORIZED IN WRITING BY CONXALL CORPORATION.

APPROVED BY: _____
DATE: _____

RoHS COMPLIANT

0A	JGK	8/15/19	DRAWING CREATED FOR PDR #18004.	
REV.	INIT.	DATE	DESCRIPTION	
	JGK	8/15/19	ORIG. DRAWN BY: DATE: 8/15/19	
ALL INFORMATION ILLUSTRATED IS THE PROPERTY OF "CONXALL CORPORATION". UNAUTHORIZED DUPLICATION OR DISTRIBUTION OF THIS DOCUMENT IS PROHIBITED.			 601 E. WILDWOOD VILLA PARK, IL 60181	
ALL UNITS ARE IN FEET, INCHES, FRACTION OF INCHES AND DECIMALS. UNLESS OTHERWISE SPECIFIED TOLERANCES: 3 PLACE DECIMALS ±.005 ANGLES ±1° FRACTIONS ±1/16				
APPROVED BY: _____			TITLE: PANEL MOUNT ASSEMBLY (5-7) #26 SOCKET CONTACTS, PC TAIL INSTA-CLICK, MICRO-CON-X STANDARD CUSTOMER	
SCALE	SIZE	SHEET	CUSTOMER: _____	
NTS	B	1 OF 1	PART NUMBER: W17984-XSG-P-300	
FILE: W17984-XSG-P-300	DIRECTORY: SLW		REV 0A	

PRELIMINARY

DIMENSIONS IS BRACKETS [] ARE METRIC