

TOP VIEW

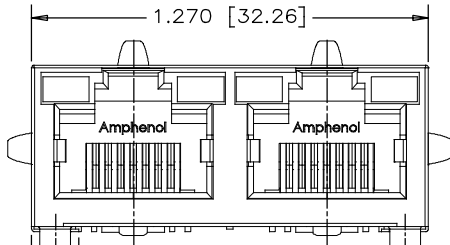

FRONT VIEW

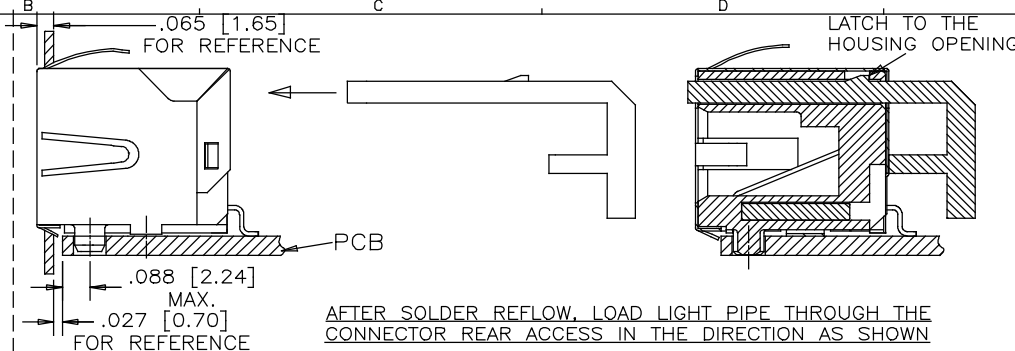

AFTER SOLDER REFLOW, LOAD LIGHT PIPE THROUGH THE CONNECTOR REAR ACCESS IN THE DIRECTION AS SHOWN

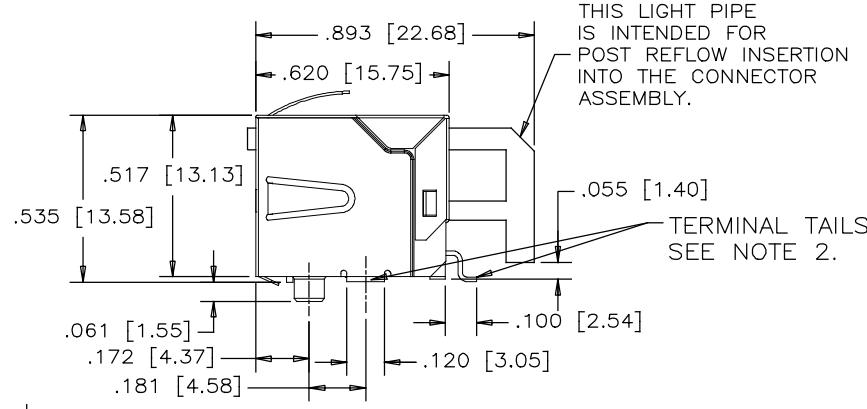

SIDE VIEW

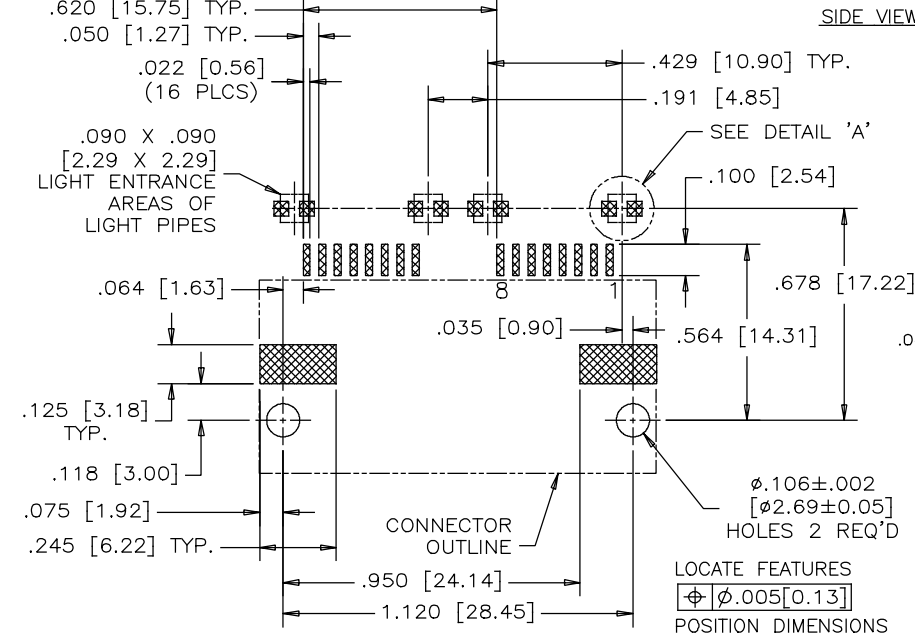

RECOMMENDED P.C.B. LAYOUT (COMPONENT SIDE OF BOARD)

THIS DOCUMENT CONTAINS PROPRIETARY INFORMATION AND SUCH INFORMATION MAY NOT BE DISCLOSED TO OTHERS FOR ANY PURPOSE OR USED FOR MANUFACTURING PURPOSES WITHOUT WRITTEN PERMISSION FROM AMPHENOL CANADA CORP.

REVISIONS				
SYM	ZONE	ECN, ERN NO.	DATE	APPRD.
A		PER ECN E07369	OCT18/07	L.C.
B		UPDATE DRAWING	NOV07/13	L.C.
C		CORRECT DIMENSION	JAN20/16	L.CHAN

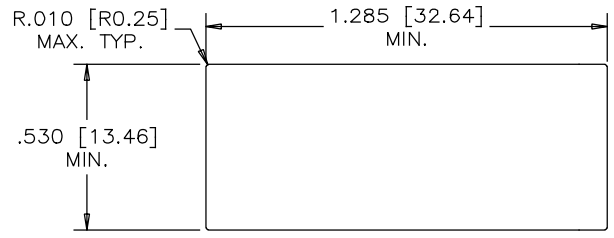

RECOMMENDED PANEL CUTOUT

1. MATERIALS:
- HOUSING: ENGINEERING THERMOPLASTIC
FLAMMABILITY RATING UL 94V-0
COLOR: BLACK
 - CONTACTS: PHOSPHOR BRONZE
 - PLATING: 50 μ" [1.27 MICRONS] MIN. GOLD ON MATING SURFACES.
50 μ" [1.27 MICRONS] MIN. NICKEL UNDERPLATE.
100 μ" [2.54 MICRONS] MIN. MATTE-TIN OR GOLD FLASH ON CONTACT TAILS.
 - SHIELD: COPPER ALLOY PLATED TIN
 - LIGHT PIPE: CLEAR POLYCARBONATE RATED UL 94V-0.

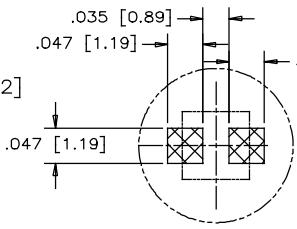

DETAIL 'A' (ENLARGED)
SMT LED SOLDER PAD
(SMT LED TO BE PROVIDED BY THE CUSTOMER)

2. COPLANARITY SPECIFICATION:
WITH THE MODULAR JACK SITTING ON A LEVEL SURFACE, THE MAXIMUM GAP BETWEEN THE LEVEL SURFACE OF SHIELD TAB AND ALL TERMINAL TAILS IS .004 [0.10].

PART NUMBER: RJSSE-5381-02T

MATERIAL	DRAWN J.OU	DATE OCT18/07
DESIGNED	CHECKED MT.CHAN	OCT18/07
I. E. APPRD. JEFF.S	Q. A. APPRD. BORIS	OCT18/07
DWG. APPRD.	ENG. REL. NO. E07369	
REF. EAR A071008	DIMENSIONS ARE IN INCHES [mm]	CODE ID. NO. 03554
FINISH		

Amphenol Canada Corp.		
TITLE: 2 PORT, SURFACE MOUNT, RJ45 MODULAR JACK, 8 POSITION, 8 CONTACTS, SHIELDED, LIGHT PIPES -ROHS COMPLIANT		
DWG C	DRAWING NO. P-RJSSE-5381-02T	REV. C
SCALE 3/1	WT. -----	SURF. -----
SHEET 1 OF 2		

REVISIONS				
SYM	ZONE	ECN, ERN NO.	DATE	APPRD.
A		PER ECN E07369	OCT18/07	L.CHAN
B		UPDATE DRAWING	NOV07/13	L.CHAN
C		CORRECT DIMENSION	JAN20/16	L.CHAN

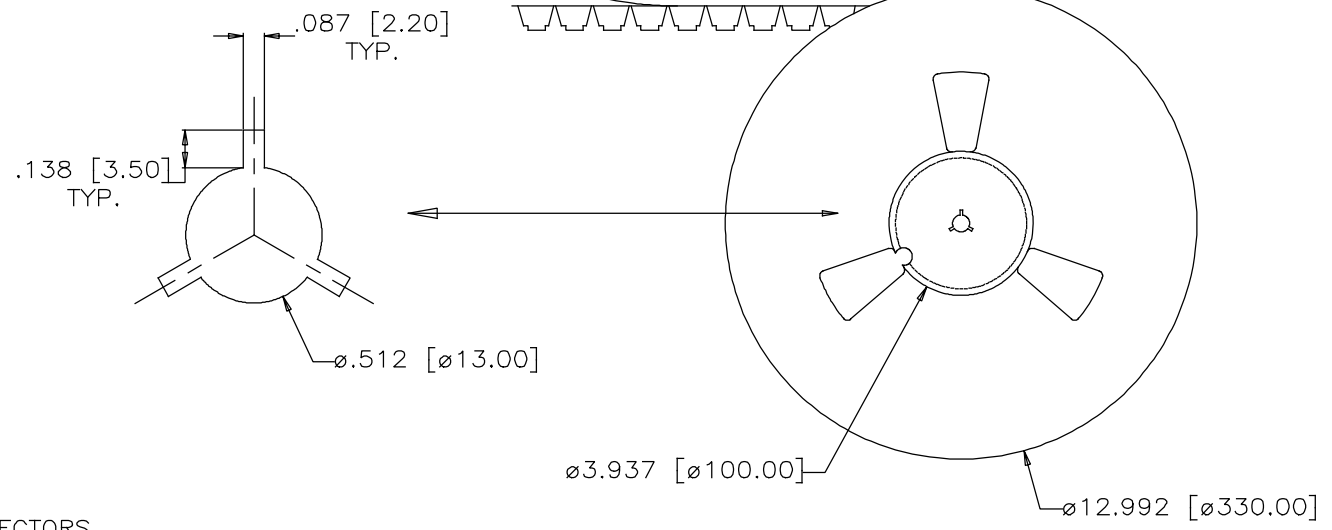
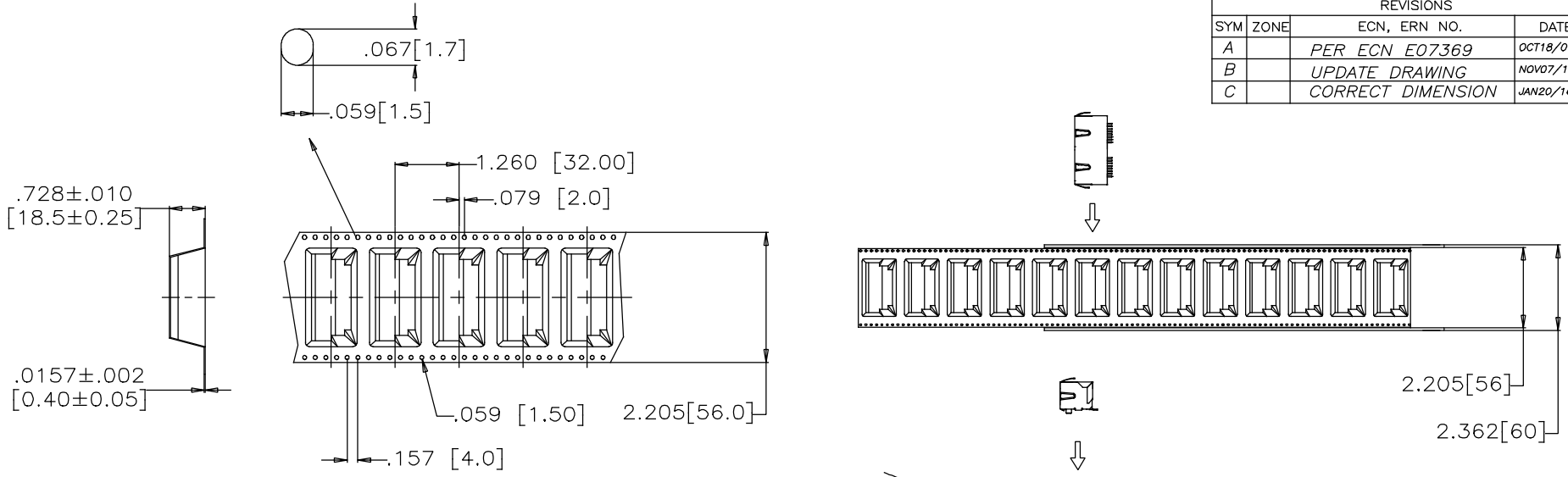

PACKAGING NOTES:

1. ONE REEL SHOULD HOLD 100 CONNECTORS.
2. 10 EMPTY CAVITIES FOR BOTH TOP AND BOTTOM OF THE CARRIER.
3. A FULLY LOADED CARTON SHOULD CONTAIN 3 REELS (300 PCS) OF CONNECTOR.
4. LIGHT PIPES WILL BE PACKED IN SEPARATE TRAYS

THIS DOCUMENT CONTAINS PROPRIETARY INFORMATION AND SUCH INFORMATION MAY NOT BE DISCLOSED TO OTHERS FOR ANY PURPOSE OR USED FOR MANUFACTURING PURPOSES WITHOUT WRITTEN PERMISSION FROM AMPHENOL CANADA CORP.

MATERIAL -----	DRAWN	J.OU	DATE	OCT18/07	Amphenol Canada Corp. TITLE 2 PORT, SURFACE MOUNT, RJ45 ,MODULAR JACK, 8 POSITION, 8 CONTACTS,SHIELDED, LIGHT PIPES -ROHS COMPLIANT
	DESIGNED				
	CHECKED	MT.CHAN		OCT18/07	
	I. E. APPRD.	JEFF.S		OCT18/07	
	Q. A. APPRD.	BORIS		OCT18/07	
FINISH -----	DWG. APPRD.				DWG C DRAWING NO. P-RJSSE-5381-02T REV. C SCALE WT. ----- SURF. ----- SHEET 2 OF 2
	ENG. REL. NO.	E07369			
	REF.	EAR A071008			
	DIMENSIONS ARE IN	INCHES [mm]	CODE ID. NO.	03554	