

CODE 54 - BRAID TAIL BACKSHELL



203M116-19B08-L

SERIES _____
 DASH NUMBER (TABLE 1) _____
 MATERIAL _____
 REFER TO CH00-0250-004
 FINISH _____
 REFER TO CH00-0250-004
 ENTRY SIZE (TABLE 2) _____
 MODIFICATION CODE _____
 REFER TO CH00-0250-004 ②

NOTES:

1. THIS PRODUCT IS DESIGNED TO TERMINATE A HEAT SHRINKABLE LIPPED BOOT TO A CONNECTOR.
- ② FOR ADDITIONAL DIMENSIONS, ORDERING INFORMATION AND MODIFICATIONS, SEE CH00-0250-004
3. BACKSHELL TO BE PERMANENTLY MARKED/BAGGED AND LABELLED WITH CODE IDENTIFICATION NUMBER AND PART NUMBER. (e.g. 06090-203M116-19B08).
- ④ WHEN ENTRY SIZE EXCEEDS "MAX ENTRY", A 2 PIECE BACKSHELL (TYPE 2) IS SUPPLIED.
5. BRAID TERMINATION RING MAY BE SUPPLIED AS TINEL-LOCK SHAPE MEMORY RING AT MANUFACTURERS OPTION.
- ⑥ BACKSHELL MATES TO MIL-C-81703, SERIES III, MS3424, MS3446, MS3464, MS3467, MS3468, CLASS E & L
- ⑦ BACKSHELL MATES TO MIL-C-5015G, MS3400 SERIES, CLASS D, E, K, L, U & W, MS3400, MS3401, MS3404, MS3406, MS3450, MS3451, MS3454, MS3456, MS3470, MS3471, MS3472, MS3474, MS3475, MS3476. MIL-C-83723, SERIES II, CLASS A & L. MIL-C-83723, SERIES I & III, CLASS A, G, K, R & S: M83723/1, /2, /3, /4, /5, /6, /7, /8, /13, /14, /36, /37, /38, /40, /41, /42, /43, /48, /49, /65, /66, /67, /68, /69, /70, /71, /72, /73, /74, /75, /76, /77, /78, /82, /83, /84, /85, /86, /87, /91, /92, /95, /97, /98, (MS3155 CONTROLLED INTERFACE).
8. WHEN "L" MODIFICATION IS SPECIFIED, COUPLING NUT SHALL HAVE 3 WIRE HOLES, 120° APART.

If this document is printed it becomes uncontrolled. Check for the latest revision

DRAWN	K.WINCZURA	DATE 20/04/2015	 3RD ANGLE PROJECTION NOT TO SCALE	TITLE: <div style="text-align: center; font-size: 1.2em;">BRAID TAIL BACKSHELL</div>	 Polamco  TE connectivity										
CHECKED		20/04/2015	UNLESS OTHERWISE SPECIFIED ALL DIMENSIONS IN MILLIMETRES GENERAL TOL LINEAR +/-0.25MM ANGULAR +/- 1°	ASSY USED ON: <div style="text-align: center; font-size: 1.2em;">MIL-DTL-26482 SERIES II / MIL-DTL-83723 SERIES I & III</div>											
APPROVED	K.SHEPPARD	27/04/2015		REVISIONS											
APPROVED	H.SMITH	02/09/2015		<table border="1" style="width: 100%; border-collapse: collapse;"> <thead> <tr> <th style="width: 5%;">LTR</th> <th style="width: 45%;">DESCRIPTION</th> <th style="width: 15%;">DATE</th> <th style="width: 35%;">APPROVED</th> </tr> </thead> <tbody> <tr> <td>N1</td> <td>REVISED PER ECO-12-011624</td> <td>21/06/2012</td> <td>K.YEE</td> </tr> <tr> <td>P</td> <td>REVISED PER ECO-15-012672</td> <td>02/09/2015</td> <td>H.SMITH</td> </tr> </tbody> </table>		LTR	DESCRIPTION	DATE	APPROVED	N1	REVISED PER ECO-12-011624	21/06/2012	K.YEE	P	REVISED PER ECO-15-012672
LTR	DESCRIPTION	DATE	APPROVED												
N1	REVISED PER ECO-12-011624	21/06/2012	K.YEE												
P	REVISED PER ECO-15-012672	02/09/2015	H.SMITH												
TE CAGE CODE: 06090 POLAMCO/TE CAGE CODE: U5792				<small>TE CONNECTIVITY - POLAMCO LTD RESERVES THE RIGHT TO AMEND THIS DRAWING AND THE INFORMATION SET FORTH HEREON AT ANY TIME. USERS SHOULD INDEPENDENTLY EVALUATE THE SUITABILITY OF THE PRODUCT FOR THEIR APPLICATION.</small>	<table border="1" style="width: 100%; border-collapse: collapse;"> <tr> <td style="width: 30%;">DRAWING NO: 203M1XX</td> <td style="width: 30%;">DRAWING REV: P</td> <td style="width: 40%;">SHT 1</td> </tr> </table>	DRAWING NO: 203M1XX	DRAWING REV: P	SHT 1							
DRAWING NO: 203M1XX	DRAWING REV: P	SHT 1													

IF MAX ENTRY IS EXCEEDED ADAPTER
WILL BE SUPPLIED AS TYPE 2



STAINLESS
STEEL
TEETH VIEW

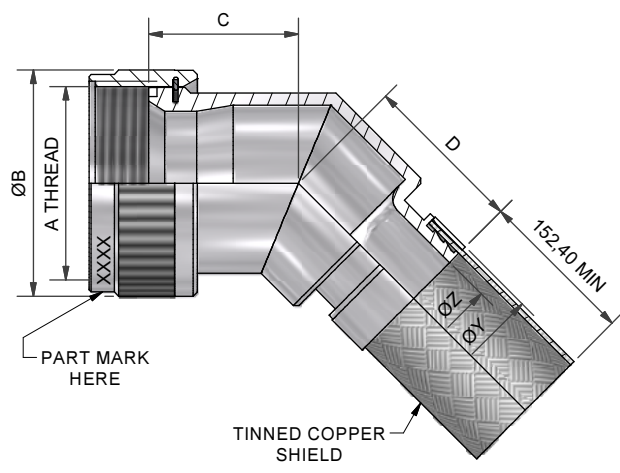

45° - TYPE 1

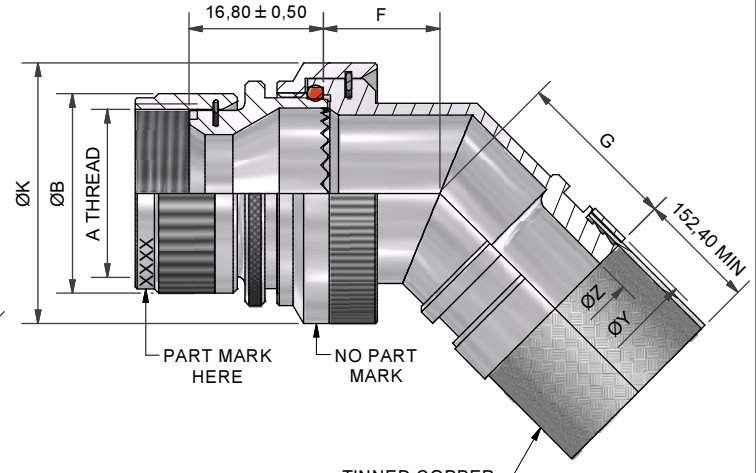

45° - TYPE 2

TABLE 1

ORDER NUMBER	SHELL SIZE		A THREAD	ØB MAX	MAX ENTRY	C ±0,5	D ±0,5
	(6)	(7)					
03	3		9/16-24 UNEF	17,0	04	16,8	16,6
08		8 & 8S	1/2-20 UNF	15,6	04	16,6	16,4
10	10	10, 10S, 10SL	5/8-24 UNEF	18,6	06	16,8	16,7
12	7	12 & 12S	3/4-20 UNEF	21,7	08	17,3	17,1
14	12	14 & 14S	7/8-20 UNEF	24,9	09	18,1	17,9
16	19	16 & 16S	1-20 UNEF	28,2	11	19,0	18,7
18	27	18	1 1/16-18 UNEF	30,9	12	19,2	19,0
20	37	20	1 3/16-18 UNEF	34,1	14	20,1	19,8
22		22	1 5/16-18 UNEF	37,3	16	20,3	20,1
24		24	1 7/16-18 UNEF	40,4	18	21,8	21,5
28		28	1 3/4-18UNS	50,0	22	23,3	22,0
32		32	2-18 UNS	56,3	24	25,0	23,7
36		36	2 1/4-16 UN	62,7	28	26,2	24,9
40		40	2 1/2-16 UN	69,0	28	28,6	26,1
44		44	2 3/4-16 UN	75,4	28	30,1	27,8
48		48	3-16UN	81,7	28	31,3	29,0
61	61		1 1/2-18 UNEF	42,0	18	22,1	21,4

TABLE 2

ENTRY SIZE	ØK MAX	ØZ REF	ØY REF	F ±0,5	G ±0,5
03	NA	4,77	13,1	NA	NA
04	NA	6,35	13,1	NA	NA
05	21,0	7,92	13,1	12,5	14,5
06	21,0	9,52	17,9	12,5	14,5
07	21,0	11,12	17,9	12,5	14,5
08	24,5	12,70	17,9	13,1	15,1
09	24,5	14,27	17,9	13,1	15,1
10	29,0	15,87	24,2	13,5	16,6
11	29,0	17,47	24,2	13,5	16,6
12	32,5	19,05	24,2	14,5	18,3
13	35,5	20,62	24,2	15,5	18,8
14	35,5	22,23	30,6	15,5	18,8
15	37,0	23,82	30,6	16,1	19,7
16	37,0	25,40	30,6	16,1	19,7
17	40,0	26,98	33,2	16,5	20,0
18	40,0	28,60	33,2	16,5	20,0
20	43,5	31,80	42,0	17,0	22,9
21	48,5	33,34	42,0	18,5	24,8
22	48,5	35,00	42,0	18,5	24,8
24	52,1	38,10	42,0	21,9	25,8
28	58,5	44,45	49,0	25,7	26,4

If this document is printed it becomes uncontrolled. Check for the latest revision

DRAWN	K.WINCZURA	DATE	20/04/2015	<p>3RD ANGLE PROJECTION NOT TO SCALE</p>	<p>TITLE:</p> <p>BRAID TAIL BACKSHELL (CODE 54)</p>	<p>Polamco</p>												
CHECKED		20/04/2015																
APPROVED	K.SHEPPARD	27/04/2015	<p>UNLESS OTHERWISE SPECIFIED ALL DIMENSIONS IN MILLIMETRES GENERAL TOL LINEAR +/-0,25MM ANGULAR +/- 1°</p>															
APPROVED	H.SMITH	02/09/2015																
<p>REVISIONS</p> <table border="1"> <thead> <tr> <th>LTR</th> <th>DESCRIPTION</th> <th>DATE</th> <th>APPROVED</th> </tr> </thead> <tbody> <tr> <td>N1</td> <td>REVISED PER ECO-12-011624</td> <td>21/06/2012</td> <td>K.YEE</td> </tr> <tr> <td>P</td> <td>REVISED PER ECO-15-012672</td> <td>02/09/2015</td> <td>H.SMITH</td> </tr> </tbody> </table>					LTR	DESCRIPTION	DATE	APPROVED	N1	REVISED PER ECO-12-011624	21/06/2012	K.YEE	P	REVISED PER ECO-15-012672	02/09/2015	H.SMITH	<p>ASSY USED ON:</p> <p>MIL-DTL-26482 SERIES II / MIL-DTL-83723 SERIES I & III</p>	<p>TE connectivity</p>
LTR	DESCRIPTION	DATE	APPROVED															
N1	REVISED PER ECO-12-011624	21/06/2012	K.YEE															
P	REVISED PER ECO-15-012672	02/09/2015	H.SMITH															
<p>TE CAGE CODE: 06090 POLAMCO/TE CAGE CODE: U5792</p>					<p>TE CONNECTIVITY - POLAMCO LTD RESERVES THE RIGHT TO AMEND THIS DRAWING AND THE INFORMATION SET FORTH HEREON AT ANY TIME. USERS SHOULD INDEPENDENTLY EVALUATE THE SUITABILITY OF THE PRODUCT FOR THEIR APPLICATION.</p>	<p>DRAWING NO:</p> <p>203M1XX</p>	<p>DRAWING REV:</p> <p>P</p>	<p>SHT</p> <p>2</p>										