

THIS DRAWING IS UNPUBLISHED. RELEASED FOR PUBLICATION  
 © COPYRIGHT BY TYCO ELECTRONICS CORPORATION. ALL INTERNATIONAL RIGHTS RESERVED.

LOC	DIST	REVISIONS					
		P	LTR	DESCRIPTION	DATE	DWN	APVD
G	14	A1		REVISED PER ECR 10-010105	25JUN10	JR	TM

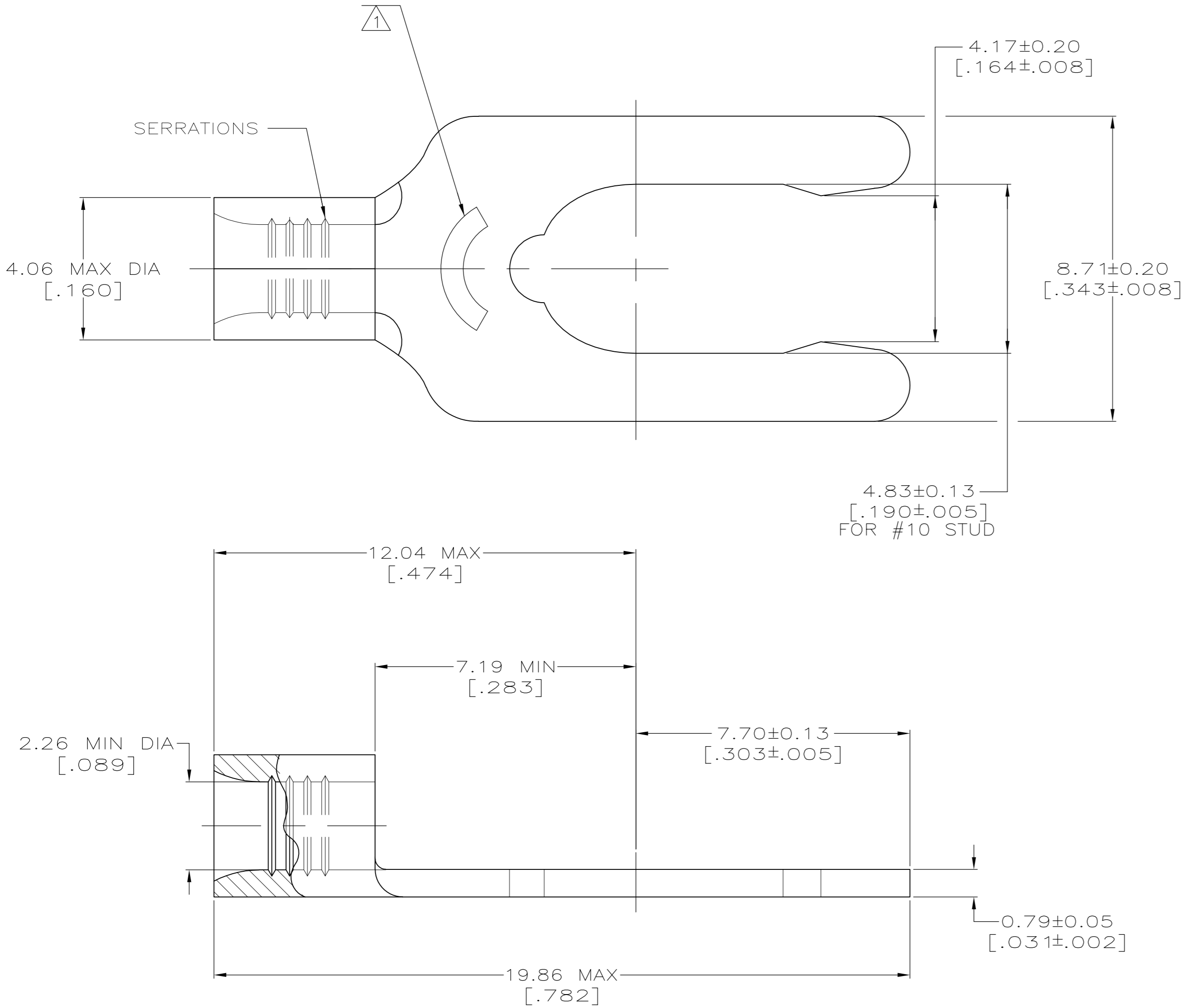

<b>AMP</b> WIRE RANGE	Listed FILE E13288	LR7189 Certified
16-14 AWG STRANDED	16-14 AWG STRANDED	NOT CERTIFIED

- ① STAMP 10S AMP 16-14\* APPROX AS SHOWN  
10S INDICATES STUD SIZE
- ② PHOSPHOR BRONZE PER ASTM B-103, ANNEALED
- ③ 0.00254 [.000100] MIN TIN PLATE  
PER ASTM B-545

52705-1  
PART NO.

<b>CUSTOMER SERVICE SYSTEMS</b>		MAX RECOMMENDED OPERATING TEMPERATURE: 170°C MAX
FOR ADDITIONAL PRODUCT INFORMATION OR COPIES OF DRAWINGS AND TECHNICAL DOCUMENTS	PRODUCT INFORMATION CENTER 1-800-522-6752	VOLTAGE RATING: --
FOR APPLICATION TOOLING INFORMATION	TOOLING ASSISTANCE CENTER 1-800-722-1111	CIRCULAR MIL AREA: 1.04-2.62mm² [2,050-5,180] STRANDED
FOR ORDER ENTRY	1-800-526-5142	THIS DRAWING IS A CONTROLLED DOCUMENT FOR AMP INCORPORATED. IT IS SUBJECT TO CHANGE AND THE CONTROLLING ENGINEERING ORGANIZATION SHOULD BE CONTACTED FOR THE LATEST REVISION.

THIS DRAWING IS A CONTROLLED DOCUMENT.	
DIMENSIONS: MM [ INCHES ]	TOLERANCES UNLESS OTHERWISE SPECIFIED:
	0 PLC ± - 1 PLC ± - 2 PLC ± - 3 PLC ± - 4 PLC ± - ANGLES ± ±
MATERIAL - ②	FINISH - ③

DWN TA BRINKMAN 2-16-93	Tyco Electronics Corporation Harrisburg, PA 17105-3608
CHK DA PATTERSON 2-16-93	
APVD JL MECKLEY 2-16-93	
PRODUCT SPEC	
APPLICATION SPEC	NAME TERMINAL, LONG SPRING SPADE, BUDGET
WEIGHT -	SIZE A2
CUSTOMER DRAWING	CAGE CODE 00779
SCALE 10:1	DRAWING NO C=52705
SHEET 1 of 1	RESTRICTED TO -
REV A1	