



HB IP65 Hood and Housing Series

Table of contents

1. INTRODUCTION	2
2. SUPPORTING DOCUMENTS	2
2.1. Customer drawings.....	2
2.2. Product specification	2
2.3. Application Specification	2
2.4. Standards	2
3. DESCRIPTION	3
3.1. Assembly product.....	3
3.2. Hood and housing types.....	4
3.2.1. Hood	4
3.2.2. Housing.....	7
3.2.2.1. Bulkhead mounted housing	7
3.2.2.2. Surface mounted housing	10
3.2.3. Cable-to-Cable Hoods.....	12
4. REQUIREMENTS.....	13
4.1.1. Panel cut-out.....	13
5. ASSEMBLY.....	14
6. ACCESSORIES.....	19
7. STORAGE	19



1. INTRODUCTION

This specification contains the regulations for assembly of various HB series IP65 Hood and Housing.

The following components are available in this system:

Hood and housing: H6B/H10B/H16B/H24B/H32B/H48B

2. SUPPORTING DOCUMENTS

2.1. Customer drawings

For dimensions and materials of the individual parts, please refer to the relative customer drawings of H6B/H10B/H16B/H24B/H32B/H48B.

2.2. Product specification

The product specifications of the used articles are to be taken into account. The product specification describes the technical data as regulations, temperature range and degree of protection. For further reference, please refer to product spec. 108-137013.

2.3. Application Specification

Connectors shall be assembled as below mentioned application specifications to ensure correct connector assembly.

2.4. Standards

- EN 61984: Connectors - Safety requirements and tests
- IEC 60664-1: Insulation coordination for equipment within low-voltage systems (Part 1)
- EN 60529: Degrees of Protection Provided by Enclosures (IP Code)
- EN 60068: Environmental testing

3. DESCRIPTION

3.1. Assembly product

The following picture (Figure 1) shows an example of complete assembly product.

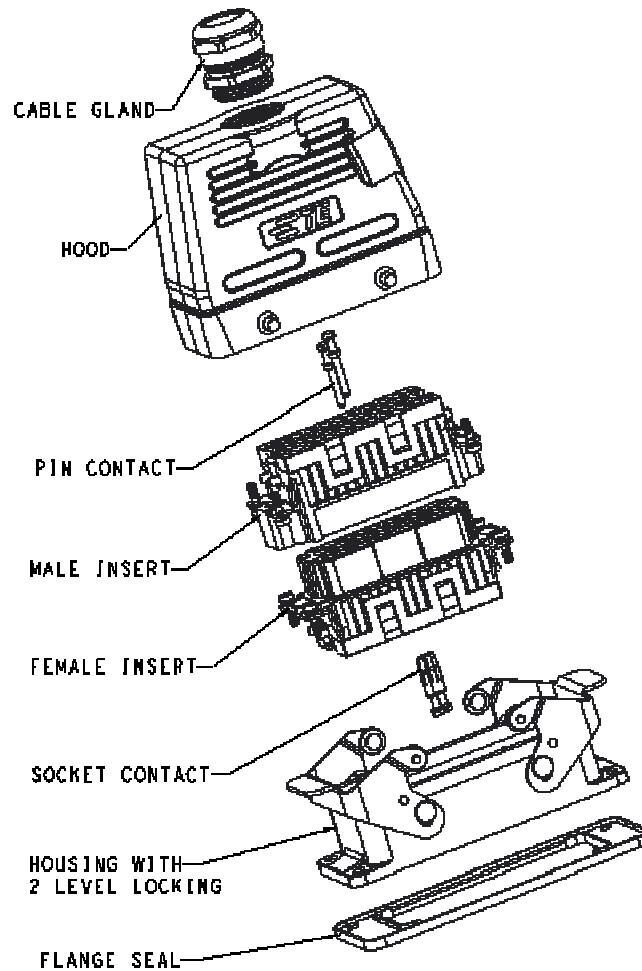

Figure: 1

The complete product consists of the following components (see figure 1):

- Cable gland
- Hood
- Pin contact
- Male insert
- Female insert
- Socket contact
- Housing
- Flange seal

3.2. Hood and housing types

3.2.1. Hood



HXXB-TSH/TS (Side entry, with 4 bolt)
H—High construction



HXXB-TGH/TG (Top entry, with 4 bolt)
H—High construction

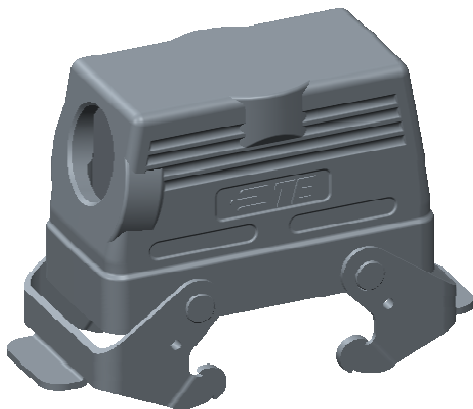

HXXB-TSBH/TSB (Side entry, with 2 level steel locking)
H—High construction



HXXB-TGBH/TGB (Top entry, with 2 level steel locking)
H—High construction



HXXB-TSBHS/TSBS
(Side entry, with 2 level stainless steel locking)
H—High construction



HXXB-TGBHS/TGBS
(Top entry, with 2 level stainless steel locking)
H—High construction



HXXB-TSH/TS-RO
(Side entry, with 2 bolt)
H—High construction

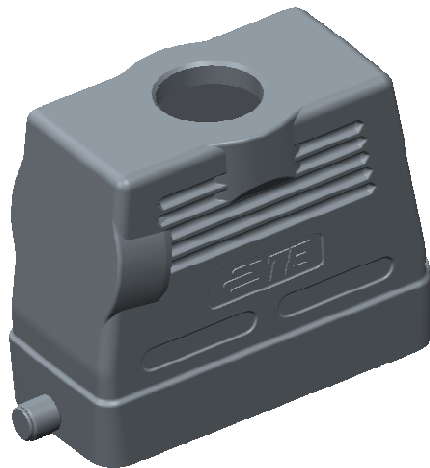

HXXB-TGH/TG-RO
(Top entry, with 2 bolt)
H—High construction

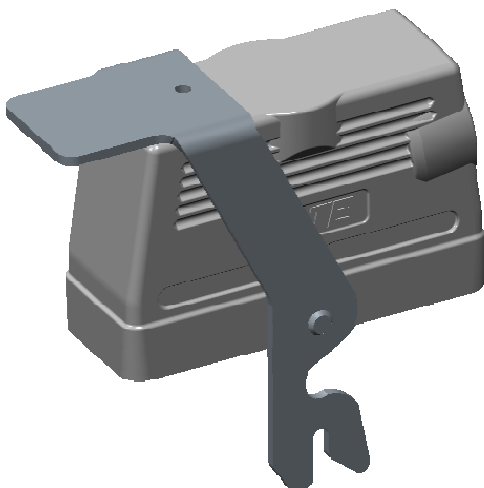

H24B-TSH-RC
(Side entry, with 1 level central locking)
H—High construction
Only H24B available for central locking

Note:

Above are the hoods for the typical applications.

For the special applications, also can be provided. The below are the examples for reference.

- Hoods without cable entry or more cable entries.
- Hoods color for Grey, Black and Silver white.
- Hoods without painting are available per the request.
- Different hoods size has different optional entry threads. Refer to drawings for the detailed information.

3.2.2. Housing

3.2.2.1. Bulkhead mounted housing

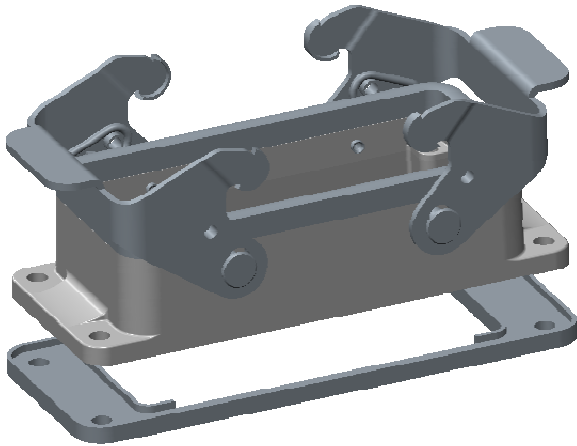

HXXB-AG, with 2 level steel locking

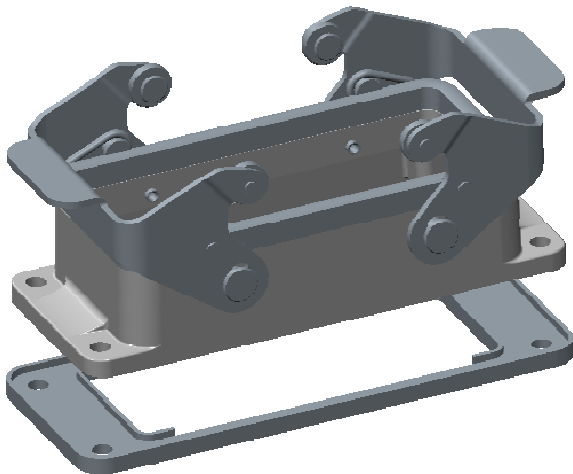

HXXB-AGS, with 2 level stainless steel locking

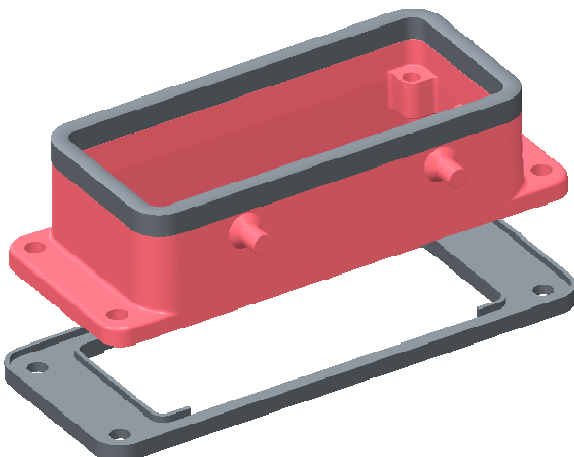

HXXB-AG-BO, with 4 blot

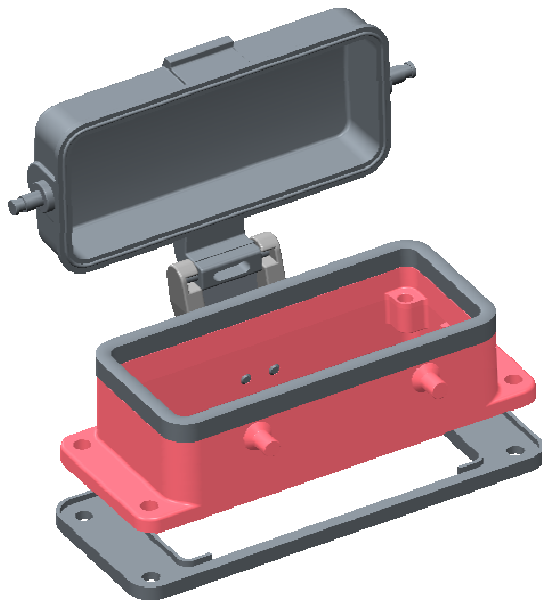

HXXB-AD-BO, with plastic protection cover and 4 blot
HXXB-ADM-BO, with metal protection cover and 4 blot

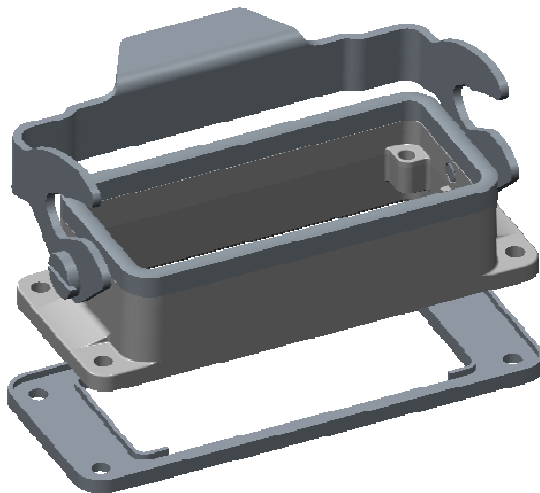

HXXB-AG-LB, with 1 level steel locking
HXXB-AGS-LB, with 1 level stainless steel locking

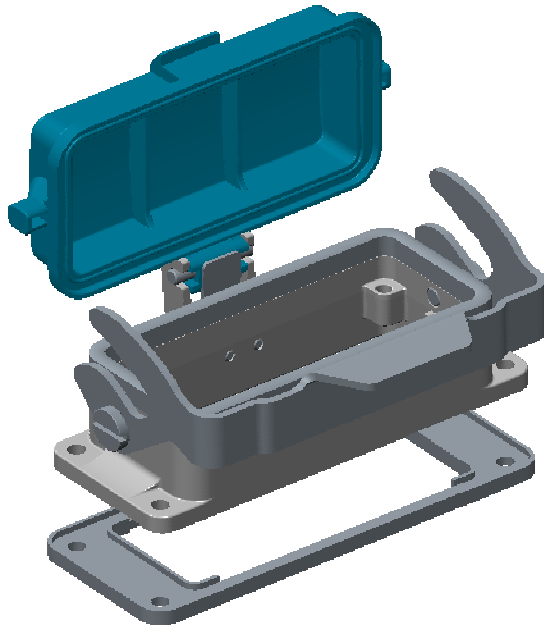

HXXB-AD-LB, with 1 level steel locking, with plastic protection cover

HXXB-ADM-LB, with 1 level steel locking, with metal protection cover

HXXB-ADS-LB, with 1 level stainless steel locking, with plastic protection cover

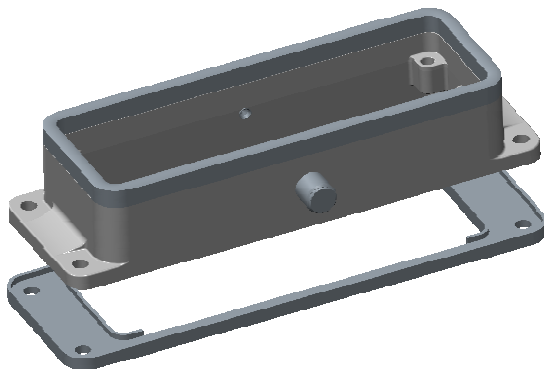

H24B-AG-RC, with central bolt

Only H24B available for central locking

Note:

Above are the housings for the typical applications.

For the special applications, also can be provided. The below are the examples for reference.

- Housings color for Grey, Black and Silver white.
- Housings without painting are available per the request.
- Different housing size refer to drawings for the detailed information.

3.2.2.2. Surface mounted housing

The surface mounted housing side entry can be supplied with one or two entries.

The arrangement and the kind of the cable entry are shown in the customer drawings.

Special customer requirements are possible per request.

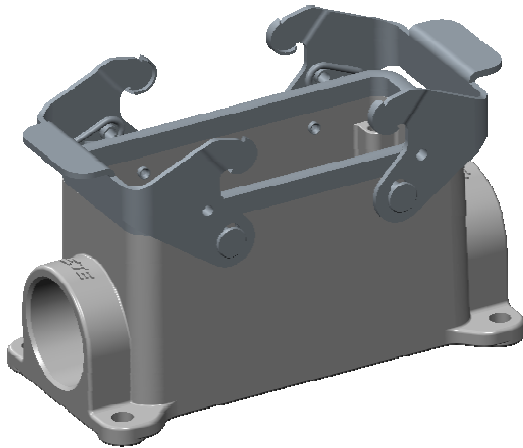

HXXB-SGR/SGRH, with 2 level steel locking
H—High construction

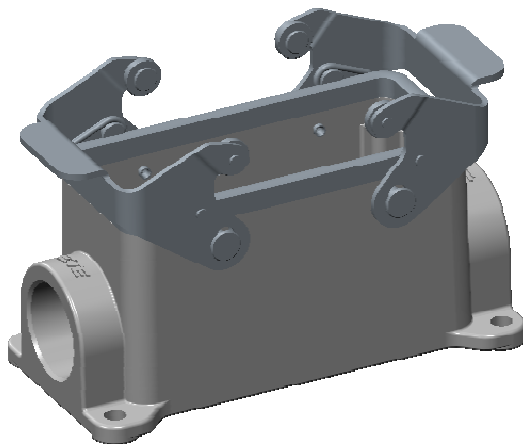

HXXB-SGRS/SGRHS, with 2 level stainless steel locking
H—High construction

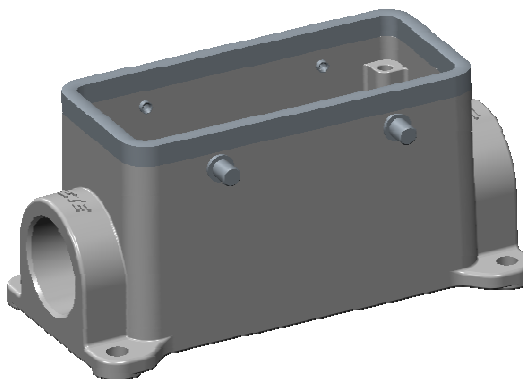

HXXB-SGR/SGRH-BO, with 4 bolt
H—High construction

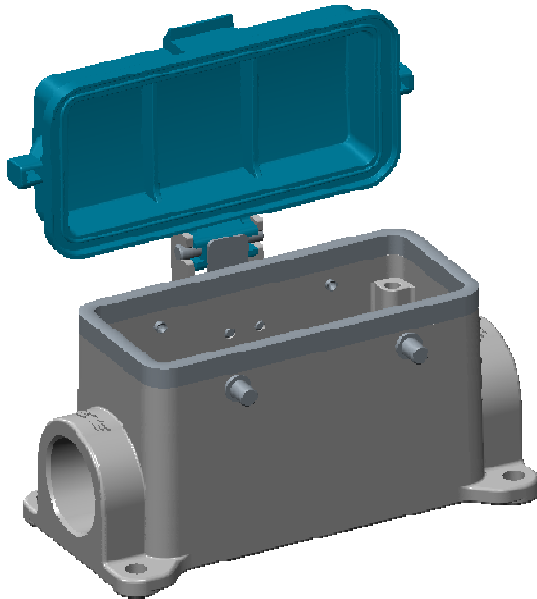

HXXB-SDR/SDRH -BO, with plastic protection cover
H—High construction
HXXB-SDRM/SDRHM-BO, with metal protection cover
H—High construction

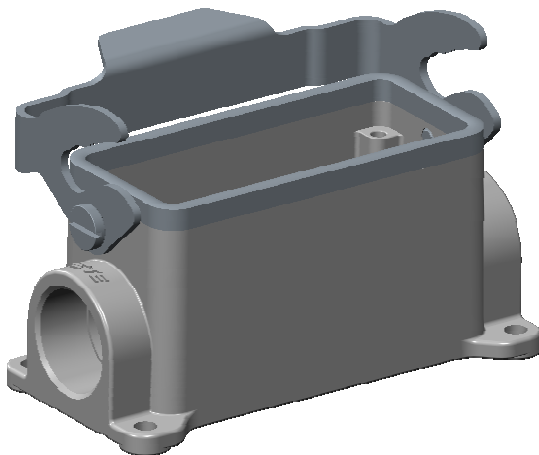

HXXB-SGR/SGRH-LB, with 1 level steel locking
H—High construction

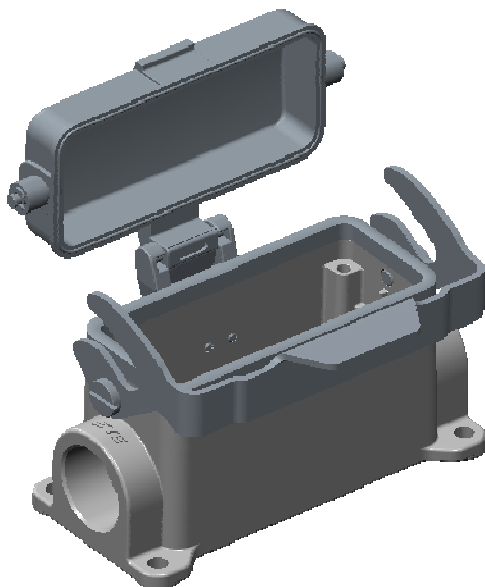

HXXB-SDR/SDRH-LB, with steel locking, with plastic protection cover
H—High construction
HXXB-SDRM/SDRHM-LB, with steel locking, with metal protection cover
H—High construction

3.2.3. Cable-to-Cable Hoods



HXXB-TBFS/TBFHS, with 2 level stainless steel locking
H—High construction

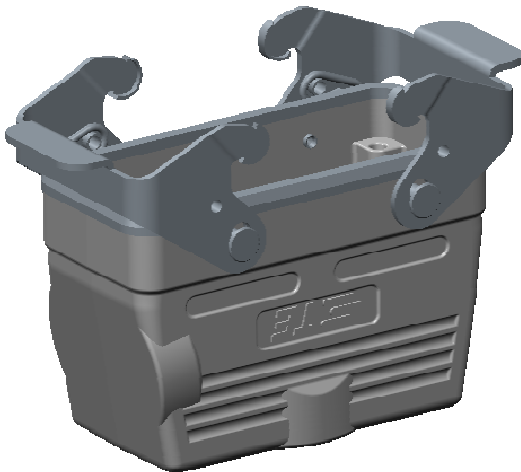

HXXB-TBF/TBFH, with 2 level steel locking
H—High construction



HXXB-TBF/TBFH-LB, with 1 level steel locking
H—High construction

4. REQUIREMENTS

4.1.1. Panel cut-out

Information concerning the panel cut-out for the use of bulkhead mounted housing can be taken from the customer drawings. Panel cut-out looks as shown in Figure 2.

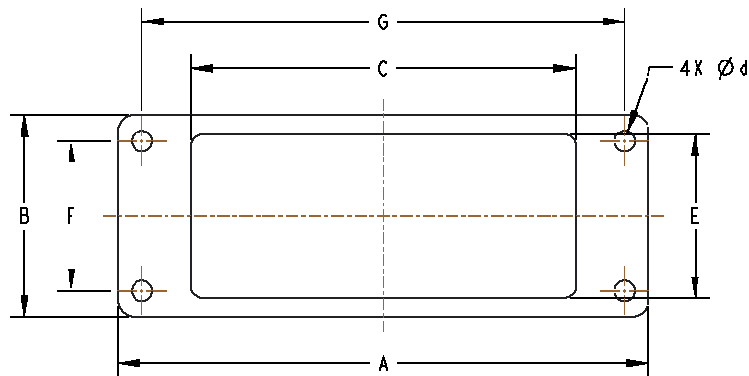

Figure: 2

Housing Size	Mounted type.	Dimension (mm)						
		A	B	C	E	F	G	Ød
H6B	Bulkhead	82	43	48	35	32	70	4.4
H10B	Bulkhead	93	43	60	35	32	83	4.4
H16B	Bulkhead	113	43	82	35	32	103	4.4
H24B	Bulkhead	140	43	108	35	32	130	4.4
H32B	Bulkhead	124	84	86	71	65	110	5.4
H48B	Bulkhead	165	96	117	81	70	148	6.4

Note: Fixing screws for the assembly housings are not part of the scope of delivery.

Initial and test-torque values can be chosen from the following table:

Recommended tightening torque for housings, bulkhead mounting			
Series	Numbers of screws	Size of screws	Recommended Tightening torque(Nm)
H3A	2	M3	0.8-1.0
H10A/H16A	4	M3	0.8-1.0
H32A	4	M4	0.8-1.0
H6B/10B/16B/24B	4	M4	0.8-1.0
H32B	4	M5	2.5 Min.
H48B	4	M6	3.0 Min.

5. ASSEMBLY

➤ Assembly housing

For bulkhead mounting housing

Fix housing with 4 x M4 screws. Tightening torque refer to spec of screws, but no less than 2Nm.

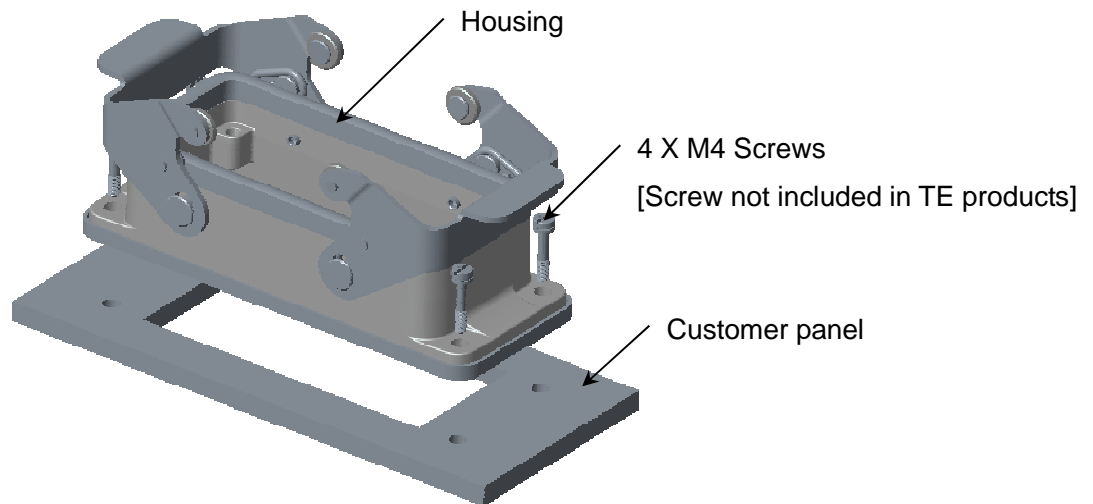

Figure: 3

For surface mounting housing

Fix housing with 4 x M5 screws. Tightening torque refer to spec of screws, but no less than 3Nm

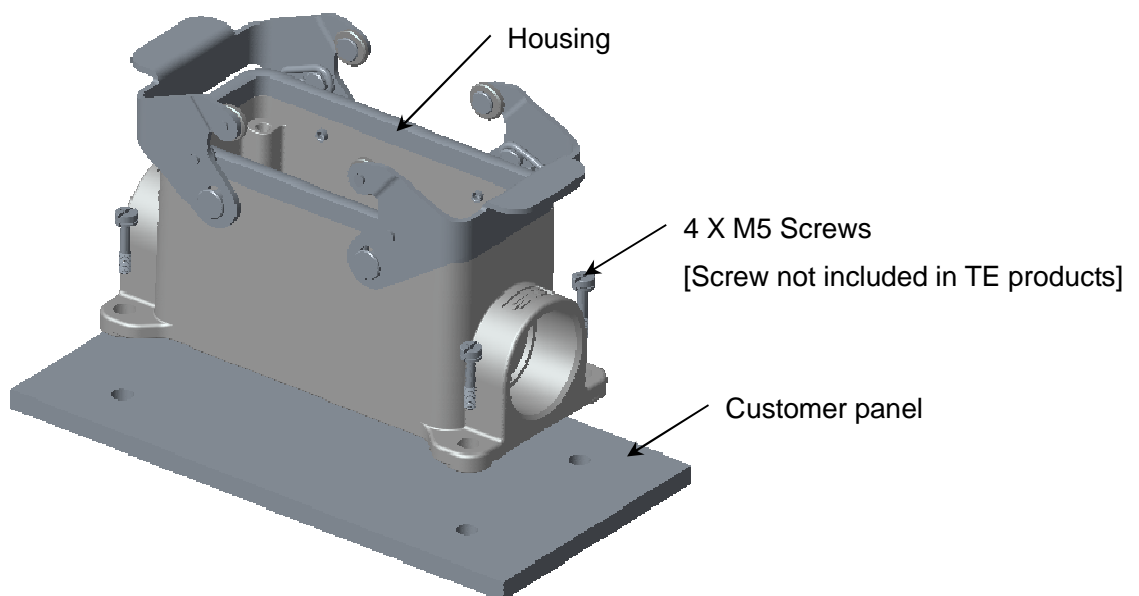

Figure: 4

➤ **Assembly female insert into housing**

Fix female insert with 4 x M3 screws. Tightening torque refer to spec of female insert.

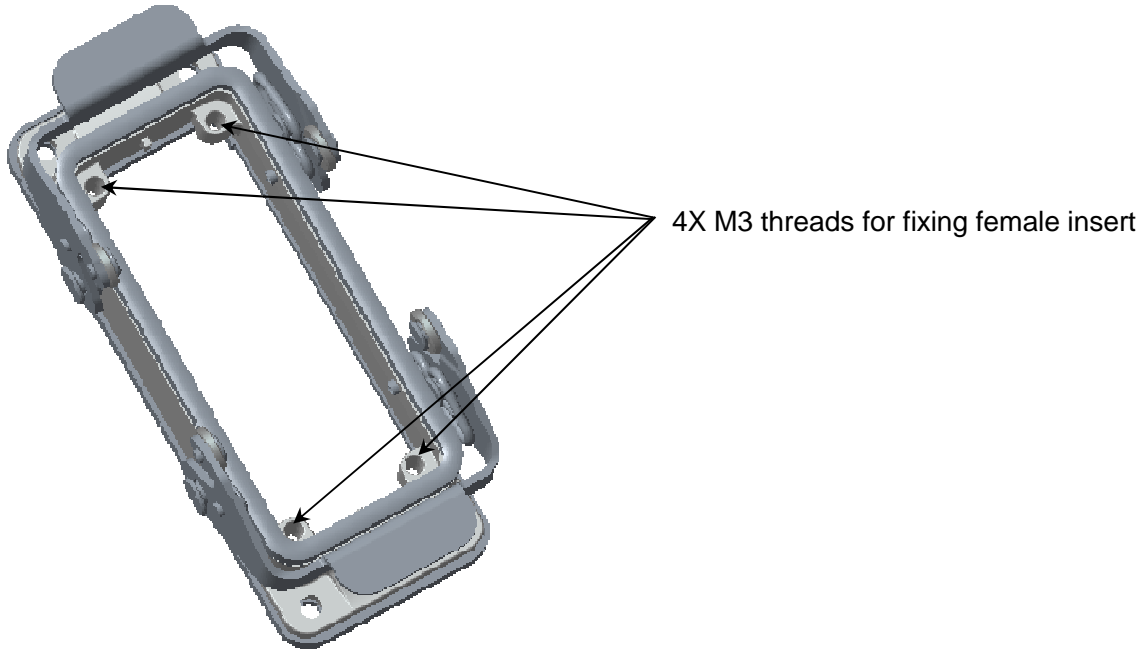

Figure: 5

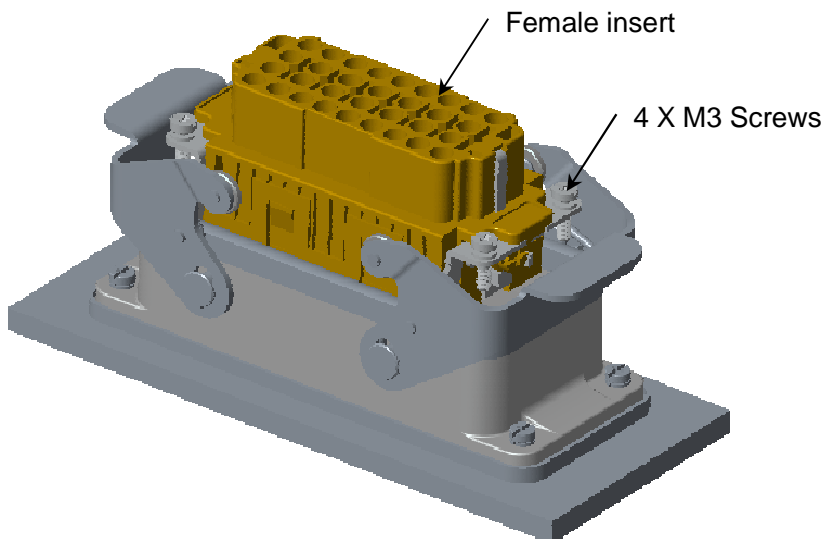

Figure: 6

Note:

- Refer application spec of female insert separately and before fixing to housing, it should be well prepared.
- Whatever the type of housing or the type of female insert, they have same assembly process here.

➤ **Assembly male insert into hood**

Fix female insert with 4 x M3 screws. Tightening torque refer to spec of male insert.

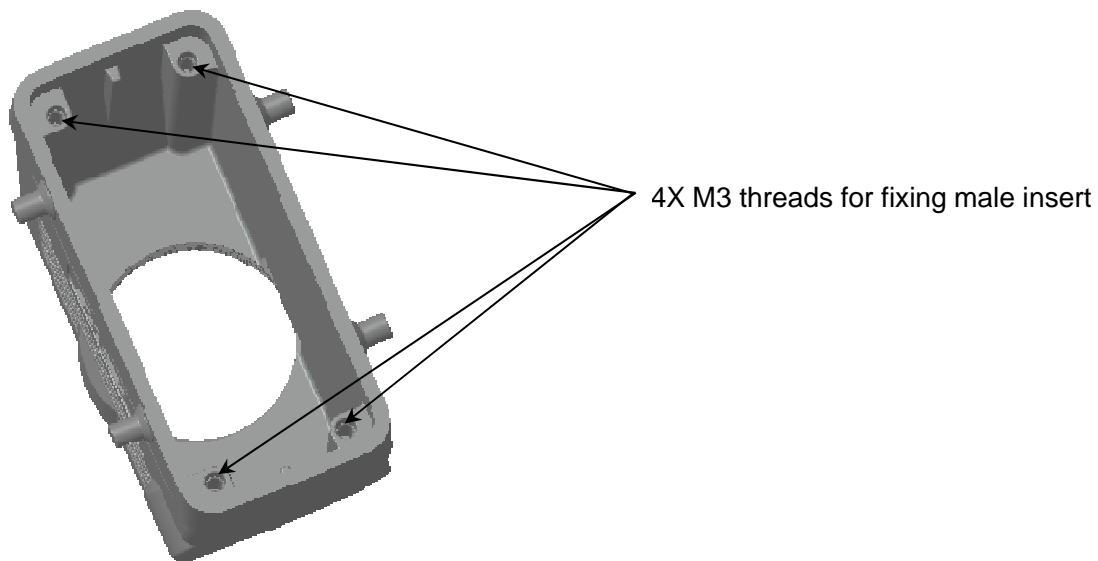

Figure: 7

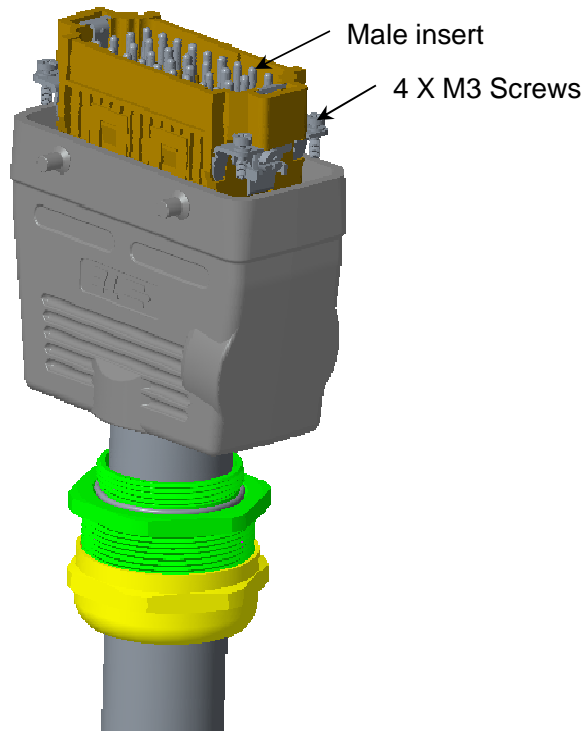

Figure: 8

Note:

- Refer application spec of male insert separately and before fixing to hood, male insert should be well prepared.
- Whatever the type of hood or the type of male insert, they have same assembly process here.

➤ **Assembly cable gland with hood**

Fix cable gland to hood. Tightening torque refer to spec of cable gland.

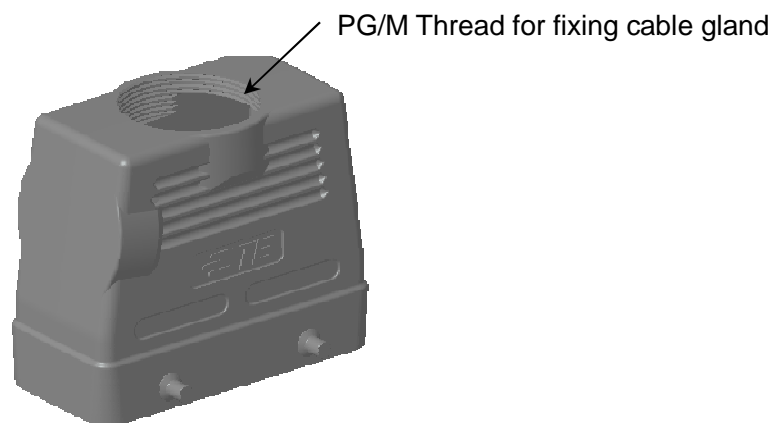

Figure: 9

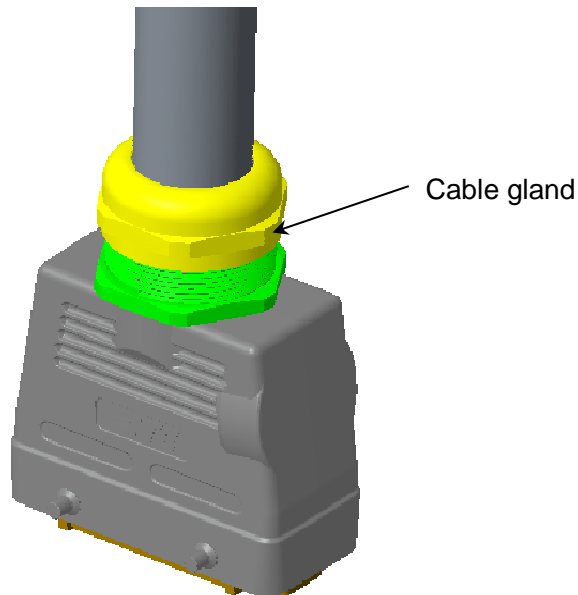

Figure: 10

Note:

- Refer application spec of cable gland separately.
- Whatever the type of hood or the type & size of thread hole, they have same assembly process here.

➤ **Assembly hood with housing**

Fix hood to housing with the locking.

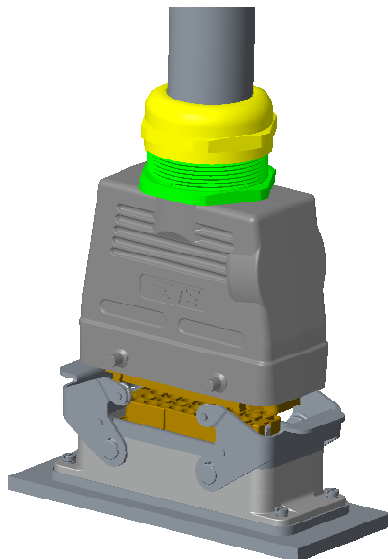

Figure: 11

Note:

- Whatever the type of hood & housing, they have same assembly process here.

6. ACCESSORIES

For the selection of cable glands, please refer to our catalogue.

The possible arrangement of fitting depends on the hood selection. All hood versions have M-threads and PG-threads.

For example, the hood and housing can be assembled with the adaptors and cable gland (plastic or metal).

As shown in Figure 12.



Figure: 12

7. STORAGE

The connectors should be stored in the air ventilation, no corrosive gas, no rain and no snow in the warehouse. Relative humidity: less than 85% RH.

NOTE Any conflict is found between this file and customer drawings, customer drawings are preferential.
 And please contact TE Connectivity related engineer if necessary.

----- End -----