

# USB 3.1 Host Card

## U31-PCIE2XG322

## USB 3.1 to PCI Express x4 (x2 mode) Gen 3 Host Card

### Highlight

- Host Bus: PCIe x4 (x2 mode) Gen 3 ; Low Profile PCI Form Factor
  - Compliant with PCI Express Base Specification Revision 3.0
  - It can configure as PCIe x2 Gen3
- 2-port USB 3.1 Host Controller (Asmedia ASM3142, USB IF TID 5080000010) for U31-PCIE2XG322 (Rev 1.2.0) or later
  - Compliant with Universal Serial Bus 3.1 specification Revision 1.0
  - Compliant with Intel's eXtensible Host Controller Interface (xHCI) specification Revision 1.1
  - Support Multiple INs function
    - It improves the efficiency of the data transfer on its USB port, when host connecting to USB 3.1 Gen2 Hub with several USB 3.1 Gen1 devices
- Provides USB 3.0 Vision Standard cable port lock mechanism

U31-PCIE2XG322-10

U31-PCIE2XG322-13

### Introduction

U31-PCIE2XG322 is a 2-port USB 3.1 Gen-II (10Gbps) to PCI Express x4 (x2 mode) Gen 3 Host Card.

U31-PCIE2XG322 is designed with the new generation Universal Serial Bus XHCI host controller, bridging PCI Express to USB3.1 Gen-II, compliant with USB 3.1 Specification Revision 1.0 and Intel eXtensible Host Controller Interface specification revision 1.1. U31-PCIE2XG322 (Rev 1.2.0 or later) also supports the new feature of USB 3.1 Gen2, named Multiple INs to achieve fully utilization rate of 10Gbps data rate, tacking advantage of the available bandwidth of USB3.1 Gen2 bus.

U31-PCIE2XG322 supports two USB 3.1 Gen-II (10Gbps) ports and perform trusting high speed bandwidth with PCIe Gen-III x2 supporting. It also supports backward compatible with legacy USB function and devices, compliant with UASP (USB Attach SCSI Protocol) Revision 1.0, supporting the XHCI debug capability. U31-PCIE2XG322 supports the proprietary driver for Windows 7 and inbox driver for Windows 8.0, Windows 8.1, Windows 10 and various Linux Kernels.

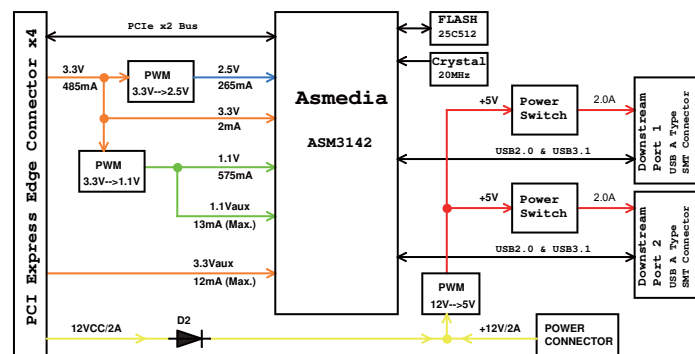

Rev 1.3

### Specification

#### PCIe Host Bus

- Support PCI Express Gen-III x2
- Support high bandwidth performance with low latency
- Support PCI Express Link power management
- Compliant with PCI Express Base 3.0 Specification
- Compliant with PCI Express card Electromechanical 2.0 specification
- Compliant with PCI Express Mini Card Electromechanical 1.2 specification
- Compliant with PCI Bus Power Management Interface Specification Revision 1.2
- Compliant with PCI Local Bus Specification Revision 3.0
- Integrate Spread Spectrum Controller for PCI Express interface
- Overclock capability on PCI Express bus

#### USB Features

- Support two ports of USB 3.1
- Up to USB3.1 Gen-II 10Gbps
- Compliant with Universal Serial Bus 3.1 Specification Revision 1.0
- Compliant with Universal Serial Bus Specification Revision 2.0
- Compliant with USB Attached SCSI Protocol Revision 1.0
- Support Multiple INs function for U31-PCIE2XG322 (Rev 1.2.0 or later)
- Support USB3.1 and USB2.0 Link Power Management
- Support Control, Bulk, Stream, Interrupt, Isochronous transfer type
- Support independent port power control
- Support overcurrent detection

- Integrate Spread Spectrum Controller for USB3.1 interface
- Backward compatible with Legacy USB function and device
- Support the Debugport

#### USB3 cable lock mechanism

Provides the threaded holes for the jack-screws of USB 3.1 A Plug w/Jackscrew lock Cable

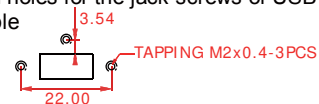

#### USB Bus Power Input

- U31-PCIE2XG322-10: USB bus power is from PCIe 12V (Step-Down)
- U31-PCIE2XG322-13: USB bus power may from the following source (A or B):
  - A. From PCIe 12V (Step-Down)
  - B. From Power Connector (IDE 4-pin or SATA 15-pin)

#### Operating Systems

- Inbox driver for Windows 8 later, Linux (kernel 3.x.x later)
- Supporting the proprietary driver for
  - Windows 7
  - Windows server 2003
  - Windows server 2008
  - Windows server 2012