

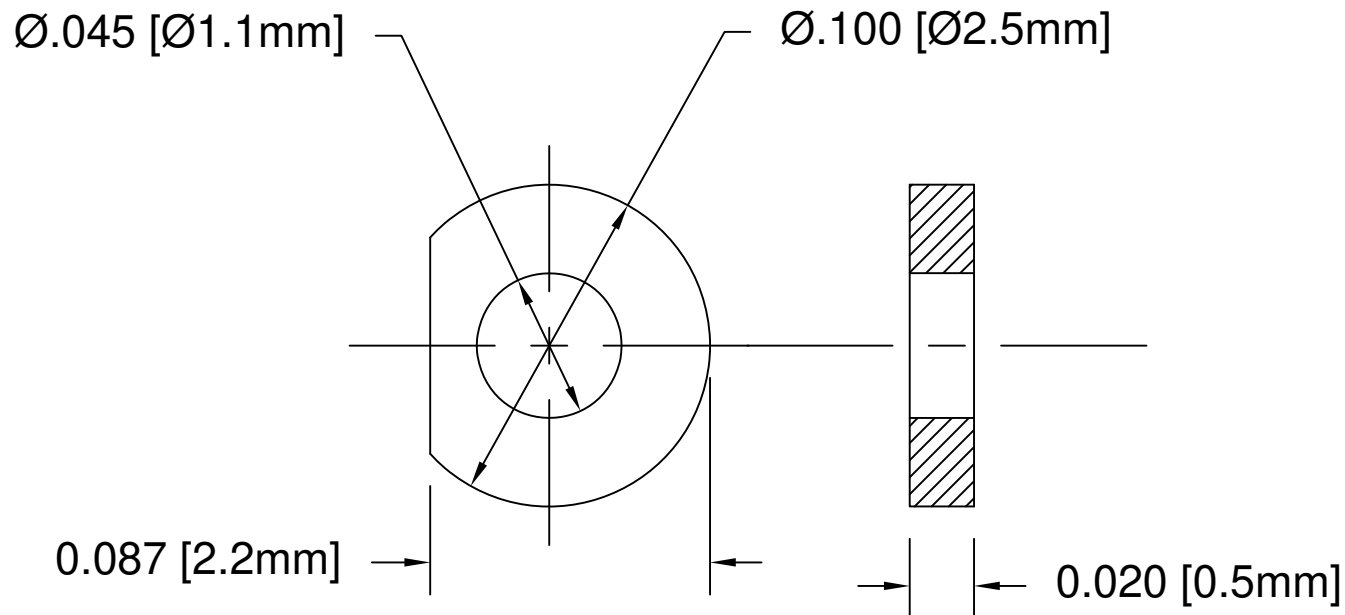

REV.	DESCRIPTION	DATE	APPROVED
C	Engineering Update w/o Changes	02/20/04	M. C.
D	Changed Material From 03-NL to 21-NL	11/11/04	M. C.
E	Corrected Typo	04/24/07	M. C.
F	Added 25-CR Material Code	08/14/07	M. C.
G	Removed Material Code	05/23/16	J. C.



2. MATERIAL: POLYESTER FILM, 94VTM-2, CLEAR.

1. GENERAL SPECIFICATIONS: BIVAR MOLDED COMPONENT SPECIFICATION BV00-E101.

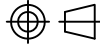
STANDARD TOLERANCE (UNLESS OTHERWISE SPECIFIED)		 BIVAR [®] 4 THOMAS, IRVINE, CA. 92618 TEL: (949) 951-8808 FAX: (949) 951-3974	
DECIMALS	ANGULAR		
.X ± .1	X° ± 1°	 PERM-O-PAD	G
.XX ± .01			
.XXX ± .005			
DESIGNED: S. Irving	DATE: 11/02/98	PART NO: 412-020	REVISION: G
CHECKED: M. Chen	DATE: 01/25/02	CAGE CODE : 32559	SHEET # 1 OF 1
CAD GENERATED DOCUMENT. DO NOT MEASURE DRAWING.			