

USB-Serial Conversion Cable

User's Manual

OMRON

USB-Serial Conversion Cable
CS1W-CIF31

User's Manual

Notice:

OMRON products are manufactured for use according to proper procedures by a qualified operator and only for the purposes described in this manual. The following conventions are used to indicate and classify precautions in this manual. Always heed the information provided with them. Failure to heed precautions can result in injury to people or damage to property.

- ⚠ **DANGER** Indicates an imminently hazardous situation which, if not avoided, will result in death or serious injury.
- ⚠ **WARNING** Indicates a potentially hazardous situation which, if not avoided, could result in death or serious injury.
- ⚠ **Caution** Indicates a potentially hazardous situation which, if not avoided, may result in minor or moderate injury, or property damage.

OMRON Product References

All OMRON products are capitalized in this manual. The word "Unit" is also capitalized when it refers to an OMRON product, regardless of whether or not it appears in the proper name of the product. The abbreviation "Ch," which appears in some displays and on some OMRON products, often means "word" and is abbreviated "Wd" in documentation in this sense. The abbreviation "PLC" means Programmable Controller. "PC" is used, however, in some Programming Device displays to mean Programmable Controller.

Visual Aids

The following headings appear in the left column of the manual to help you locate different types of information.

Note Indicates information of particular interest for efficient and convenient operation of the product.

1,2,3... 1. Indicates lists of one sort or another, such as procedures, checklists, etc.

© OMRON, 2003

All rights reserved. No part of this publication may be reproduced, stored in a retrieval system, or transmitted, in any form, or by any means, mechanical, electronic, photocopying, recording, or otherwise, without the prior written permission of OMRON.

No patent liability is assumed with respect to the use of the information contained herein. Moreover, because OMRON is constantly striving to improve its high-quality products, the information contained in this manual is subject to change without notice. Every precaution has been taken in the preparation of this manual. Nevertheless, OMRON assumes no responsibility for errors or omissions. Neither is any liability assumed for damages resulting from the use of the information contained in this publication.

TABLE OF CONTENTS

Notice:	2
OMRON Product References.....	2
Visual Aids.....	2
TABLE OF CONTENTS.....	3
About this Manual	4
PRECAUTIONS	5
Overview and Components.....	8
Overview	8
Appearance and Component Names.....	8
Packing Lists.....	9
D-sub Connector Cable (CS1W-CIF31).....	9
Specifications.....	10
Compatible Operating Systems	10
Compatible Software Applications	10
Compatible PLCs, PTs and Programmable Relay	11
Connection Configurations	12
General Specifications	13
Dimensions	14
D-sub Connector Cable.....	14
System Configuration.....	15
CS/CJ-series PLCs	15
C-series PLCs	17
CVM1 and CV-series PLCs.....	20
PTs (NS and NT Series)	21
Programmable Relay (ZEN).....	21
USB to PLC/PT Connection Tables	22
Connecting with the CS1W-CIF31 (D-sub Connector Cable).....	22
Application Procedure.....	27
Cable Connections	28
Connecting the Cable.....	28
Installing the Drivers	29
Uninstalling the Drivers	33
Connecting Online from the CX-Programmer	34
Using More than One Conversion Cable	38
Revision History	39
Index	40

About this Manual

Thank you for purchasing the CS1W-CIF31 USB-Serial Conversion Cable. The CS1W-CIF31 USB-Serial Conversion Cable connects an OMRON PLC (or PT) to a personal computer's USB port.

Please read this manual carefully and be sure you understand the information provided before attempting to install or operate the USB-Serial Conversion Cables. Be sure to read the precautions provided in the following section.

Precautions provides general precautions for using the USB-Serial Conversion Cables and related devices.

Overview and Components describes the parts of the USB-Serial Conversion Cables and gives an overview of their application.

Packing Lists shows the various items that come with the USB-Serial Conversion Cables.

Specifications provides the hardware and software specifications.

Dimensions shows external cable dimensions.

System Configuration shows the application of the USB-Serial Conversion Cables with various models of PLC.

USB to PLC/PT Connection Tables lists the possible combinations of Cables, Units, and ports that can be used.

Application Procedure gives an overview of the steps required to use USB-Serial Conversion Cables.

DIP Switch Settings and Cable Connections describes switch settings and cable connections.

Installing the Drivers tells how to install the software drivers.

Uninstalling the Drivers tells how to uninstall the software drivers.

Connecting Online from the CX-Programmer tells how to connect to a PLC or PT from a computer running the CX-Programmer.

⚠ WARNING Failure to read and understand the information provided in this manual may result in personal injury or death, damage to the product, or product failure. Please read each section in its entirety and be sure you understand the information provided in the section and related sections before attempting any of the procedures or operations given.

PRECAUTIONS

This section provides general precautions for using the USB-Serial Conversion Cable and related devices.

The information contained in this section is important for the safe and reliable application of the USB-Serial Conversion Cable. You must read this section and understand the information contained before attempting to set up or operate a USB-Serial Conversion Cable and PLC system.

■ Intended Audience

This manual is intended for the following personnel, who must also have knowledge of electrical systems (an electrical engineer or the equivalent).

- Personnel in charge of purchasing FA devices.
- Personnel in charge of designing FA systems.
- Personnel in charge of managing FA systems and facilities.

■ General Precautions

- The user must operate the product according to the performance specifications described in the operation manuals.
- Consult your OMRON representative before using the product under conditions which are not described in the manual or applying the product to nuclear control systems, railroad systems, aviation systems, vehicles, combustion systems, medical equipment, amusement machines, safety equipment, and other systems, machines, and equipment that may have a serious influence on lives and property if used improperly.
- This manual provides important information for using the CS1W-CIF31 USB-Serial Conversion Cable. Be sure to read this manual before attempting to use the Conversion Cable and keep this manual close at hand for reference during operation.

⚠ WARNING It is extremely important that a PLC and all PLC Units be used for the specified purpose and under the specified conditions, especially in applications that can directly or indirectly affect human life. You must consult with your OMRON representative before applying a PLC system to the above mentioned applications.

■ Operating Environment Precautions

Do not use the USB-serial Conversion Cable in the following places:

- Locations subject to strong electromagnetic fields.
- Locations subject to direct sunlight.
- Locations subject to temperatures or humidity outside the range specified in the specifications.
- Locations subject to condensation as the result of severe changes in temperature.
- Locations subject to corrosive or flammable gases.
- Locations subject to excessive dust, or salts, or metal filings.
- Locations subject to exposure to water, oil, or chemicals.
- Locations subject to shock or vibration.

Provide proper shielding when installing in the following locations:

- Locations subject to static electricity or other sources of noise.
- Locations subject to strong electromagnetic fields.
- Locations subject to possible exposure to radiation.
- Locations near power supply lines.

PRECAUTIONS

■ Application Precautions

- Observe the following precautions when using the USB-Serial Conversion Cable.
- These cables are designed specifically to connect a personal computer to an OMRON PLC or PT. Do not use them to connect any other devices and do not use a commercially available USB-serial conversion cable in place of these cables. Improper usage of these cables may result in damage to external devices, the PLC, or the PT.
 - Do not attempt to disassemble, repair, or modify any Units.
 - Touch a grounded metal object to discharge any static electricity before connecting the Conversion Cable to the PLC's connector, a PLC Connecting Cable, or the personal computer's USB port.
 - To avoid malfunctions due to noise, do not route the Conversion Cable parallel or close to a high-tension power line.
 - Tighten the D-sub connector screws to a torque of 0.4 N·m.
 - Either turn OFF the power supply to the computer or disconnect the cable from the USB connector before setting the DIP switch.
 - Always lock any connectors that are equipped with locking mechanisms.
 - Do not place anything on the cable.
 - Do not bend the cable past its normal bending radius or pull on the cable.
 - Touch the Unit only after touching a grounded metal object to release static electricity from your body.
 - Disconnect or connect the cable only after confirming that communications are not in progress.
 - Do not quickly and repeatedly connect and disconnect the USB connector. Doing so may cause the computer to malfunction.
 - It may take some time for the computer to detect the cable after the cable is connected. This is not a malfunction.
 - Do not connect the RS-232C connector on the CS1W-CIF31 Cable (D-sub type) directly to the RS-232C or RS-422/485 connector on the PLC. The cable may malfunction.
 - Do not connect this cable to a USB hub; connect it directly to a USB connector on the computer. The cable may malfunction.
 - Do not extend the USB portion of this cable with an extension cable. The cable may malfunction.
 - Set the communications port (COM port) number used by the software to the communications port (COM port) number allocated to the Conversion Cable.

<p> Caution Perform wiring so that the power supply wires are not exposed and do not come into contact with any metal parts. Contact with metal parts may cause a fire.</p>

■ EC Directives

● Applicable Directives

- EMC Directives
- Low Voltage Directive

● Concepts

• EMC Directives

OMRON devices that comply with EC Directives also conform to the related EMC standards so that they can be more easily built into other devices or the overall machine. The actual products have been checked for conformity to EMC standards (see the following note). Whether the products conform to the standards in the system used by the customer, however, must be checked by the customer.

EMC-related performance of the OMRON devices that comply with EC Directives will vary depending on the configuration, wiring, and other conditions of the equipment or control panel on which the OMRON devices are installed. The customer must, therefore, perform the final check to confirm that devices and the overall machine conform to EMC standards.

Note: Within the EMC (Electromagnetic Compatibility) standards, the applicable EMS (Electromagnetic Susceptibility) standard is EN61000-6-2 and the applicable EMI (Electromagnetic Interference) standard is EN61000-6-4 (10-m regulations.)

• Low Voltage Directive

Always ensure that devices operating at voltages of 50 to 1,000 VAC and 75 to 1,500 VDC meet the required safety standards (EN61131-2).

• Conformance to EC Directives

The CS1W-CIF31 USB-Serial Conversion Cables comply with EC Directives. Observe the following precautions to ensure that the machine or device in which the Conversion Cable is used complies with EC directives:

1. The CS1W-CIF31 USB-Serial Conversion Cable must be installed within a control panel.
2. Reinforced insulation or double insulation must be used for the DC power supplies providing the communications power supply and I/O power supplies.
3. CS1W-CIF31 USB-Serial Conversion Cables complying with EC Directives also conform to the Common Emission Standard (EN61000-6-4). Radiated emission characteristics (10-m regulations) may vary depending on the configuration of the control panel used, other devices connected to the control panel, wiring, and other conditions. You must therefore confirm that the overall machine or equipment complies with EC Directives.

Overview and Components

Overview

The CS1W-CIF31 USB-Serial Conversion Cable connects an OMRON PLC (Programmable Controller) or PT (Programmable Terminal) to a personal computer's USB port. The cable can be used once the required drivers (on the provided CD-ROM) have been installed in the personal computer. The Conversion Cable can be used with OMRON PLC/PT software, such as the CX-Programmer, which use the CX-Server or FinsGateway as a communications driver, as well as other OMRON Software, such as the DeviceNet Configurator.

Appearance and Component Names

■ D-sub Connector Cable

● CS1W-CIF31 (USB Connector to D-sub Connector)

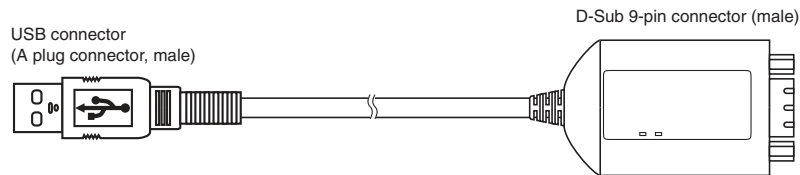

LED Indicators

Indicator	Color	Status	Description
TD	Yellow	Flashing	Data is being sent from the USB-Serial Conversion Cable.
		OFF	Data is not being sent from the USB-Serial Conversion Cable.
RD	Yellow	Flashing	The USB-Serial Conversion Cable is receiving data.
		OFF	The USB-Serial Conversion Cable is not receiving data.

Packing Lists

D-sub Connector Cable (CS1W-CIF31)

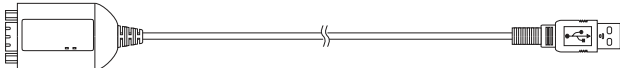
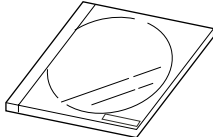
Name	Appearance
CS1W-CIF31 (USB Connector to D-sub Connector Conversion Cable)	
Drivers (On CD-ROM)	
User's Manual (this manual) (On CD-ROM in PDF format)	
Instruction Sheet	

Specifications

Compatible Operating Systems

Windows 98/ME/2000/XP/Vista

Compatible Software Applications

The compatible software applications communicate with the PLC using the CX-Server or FinsGateway. The following software applications use CX-Server or FinsGateway.

Name	Communications software
CX-Programmer	CX-Server (FinsGateway is used for network communications.)
CX-Simulator	FinsGateway
CX-Protocol	CX-Server (FinsGateway is used for network communications.)
CX-Position	FinsGateway
CX-Motion	CX-Server
CX-Process	FinsGateway or CX-Server
NS-Designer	FinsGateway
PLC Reporter	FinsGateway

The following software applications are also compatible.

- DeviceNet Configurator
- NT Support Tool for Windows
- ZEN Support Software Ver. 3.0 or later
- Software applications in CX-One

• **Communications Port Limitations with the NT Support Tool**

1) Version 4.00 and Earlier Versions

Only communications ports COM1 and COM2 can be used. Always change the communications port allocation for this device to COM1 or COM2 in the Microsoft Windows Device Manager (see note 1) and specify that port in the NT Support Tool's communications settings. Once the communications port is specified correctly in the Windows Device Manager and the NT Support Tool's communications settings, data such as screen data can be downloaded to the PT or uploaded from the PT through the USB-Serial Conversion Cable.

Note: In most personal computers, COM1 is allocated to the RS-232C port and communications port COM2 can be allocated to the Conversion Cable. Refer to *Changing the Allocated Communications Port* on page 36 for details on changing the communications port. Furthermore, if there is another driver using the allocated port, that driver must be uninstalled.

2) Version 4.60E and Later Versions

Any communications port between COM 1 and COM8 can be used. Check the NT Support Tool's communications settings and verify that the communications port allocated to the Conversion Cable is also specified in the NT Support Tool.

• Limitations when Using the NT Support Tool's System Installer

1) Windows 98 and Windows Me

The system program cannot be downloaded to the PT through the USB-Serial Conversion Cable.

2) Windows 2000, Windows XP, and Windows Vista

Only communications ports COM1 and COM2 can be used. Always change the communications port allocation for this device to COM1 or COM2 in the Microsoft Windows Device Manager (see note 1) and specify that port in the NT Support Tool's communications settings. Once the communications port is specified correctly in the Windows Device Manager and the NT Support Tool's communications settings, the system program can be downloaded to the PT through the USB-Serial Conversion Cable.

Note: In most personal computers, COM1 is allocated to the RS-232C port and communications port COM2 can be allocated to the Conversion Cable. Refer to *Changing the Allocated Communications Port* on page 36 for details on changing the communications port. Furthermore, if there is another driver using the allocated port, that driver must be uninstalled.

Compatible PLCs, PTs and Programmable Relay

The following OMRON PLCs, PTs and Programmable Relay are supported by the compatible software applications.

• PLCs

CS/CJ-series, C-series (see note 1), and CVM1/CV-series

• PT

NS-series and NT-series

• Programmable Relay

ZEN (see note 2)

Note 1. The following C-series PLCs are supported: C200HS, C200HX/HG/HE, C200H, C1000H, C2000H, CQM1, CPM1, CPM1A, CPM2A, SRM1, CQM1H, and CPM2C.

Note 2. The ZEN Programmable Relay is supported only if ZEN Support Software Ver. 3.0 or later is used.

Specifications

Connection Configurations

The following table shows the connection configurations that can be used to connect an OMRON PLC (or PT) to a personal computer's USB port.

USB-Serial Conversion Cable	Conversion Cable's serial connector	Required adapters or cables	Compatible PLC or PT connector	Compatible PLCs and PTs
CS1W-CIF31 (D-sub version)	D-sub 9-pin male	•CS1W-CN226/626 (Programming Device Connecting Cable for a CS/CJ-series peripheral port and personal computer)	CS/CJ-series peripheral port	CS/CJ-series, CQM1H, and CPM2C
		•XW2Z-200/500S-CV or XW2Z-200/500S-V (Programming Device Connecting Cable for an RS-232C port and personal computer)		
		+		
		•CS1W-CN118 (RS-232C to CS/CJ-series peripheral port Conversion Cable)		
		•CQM1-CIF02 (Programming Device Connecting Cable for a C-series peripheral port and personal computer)		
		+		
		•CS1W-CN114 (C-series peripheral port to CS/CJ-series peripheral port Conversion Cable)		
•CQM1-CIF02 (Programming Device Connecting Cable for a C-series peripheral port and personal computer)	C-series peripheral port	C200HS, C200HX/HG/HE, CQM1, CPM1, CPM1A, CPM2A, and SRM1		
•RS-232C 9-pin to 25-pin adapter	CV-series peripheral port	CVM1/CV-series		
+				
•CV500-CIF01 (Programming Device Connecting Cable for a CV-series peripheral port and PC98-type personal computer)				
•XW2Z-200/500S-CV or XW2Z-200/500S-V (Programming Device Connecting Cable for an RS-232C port and personal computer)	RS-232C port (D-sub 9-pin)	PLCs (CPU Unit or Serial Communication Unit/Board connection) or PTs		
ZEN-CIF01 (Personal Computer Connecting Cable)	Personal Computer Connecting port	ZEN		

Note The USB-Serial Conversion Cables are for connections between a USB port and an OMRON PLC/PT only. In particular, the CS1W-CIF31 Cable can be used only with compatible OMRON software applications even though it has a standard D-sub 9-pin connector on one end.

General Specifications

USB Interface rating		Conforms to USB Specification 1.1
DTE speed		115.2 kbps
Connector specifications	Computer end	USB (type A plug, male)
	PLC end	RS-232C (D-sub 9-pin, male)
Power supply		Bus power (5 VDC power from upstream)
Current consumption		35 mA
Operating environment	Ambient temperature	0 to 55°C
	Ambient humidity	10% to 90% humidity (with no condensation)
	Atmosphere	No corrosive gases
Weight		50 g

Dimensions

D-sub Connector Cable

■ CS1W-CIF31

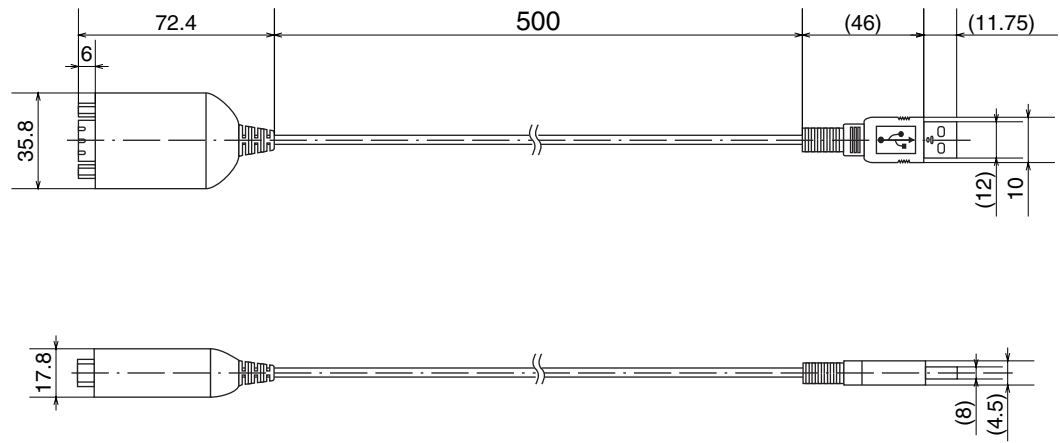

System Configuration

CS/CJ-series PLCs

• Connecting to the Peripheral Port

• Using a CS1W-CN226/626 Cable

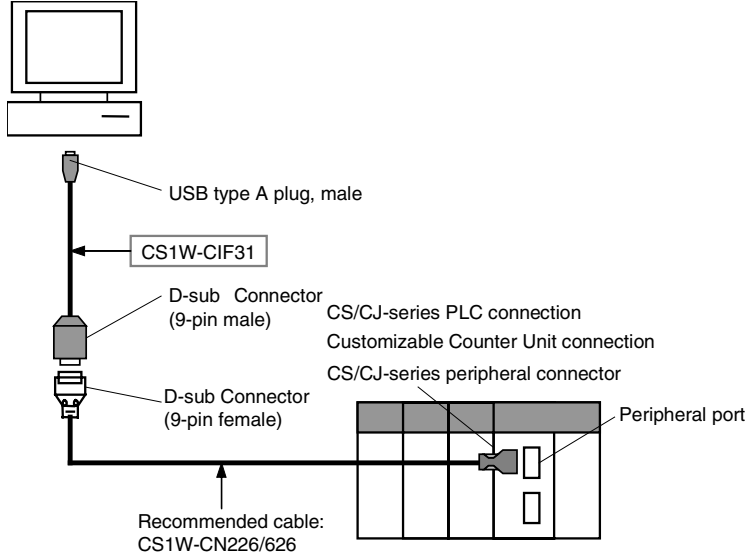

• Using a CQM1-CIF02 Cable

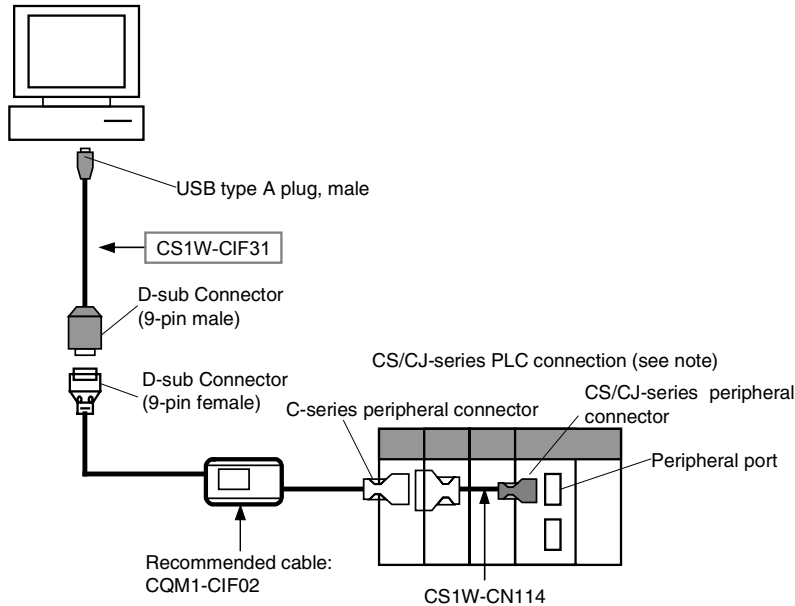

Note: With a CS/CJ-series PLC, the connection must be a host link connection.

System Configuration

- Using a XW2Z-200S-CV/500S-CV or XW2Z-200S-V/500S-V Cable for an RS-232C Connection

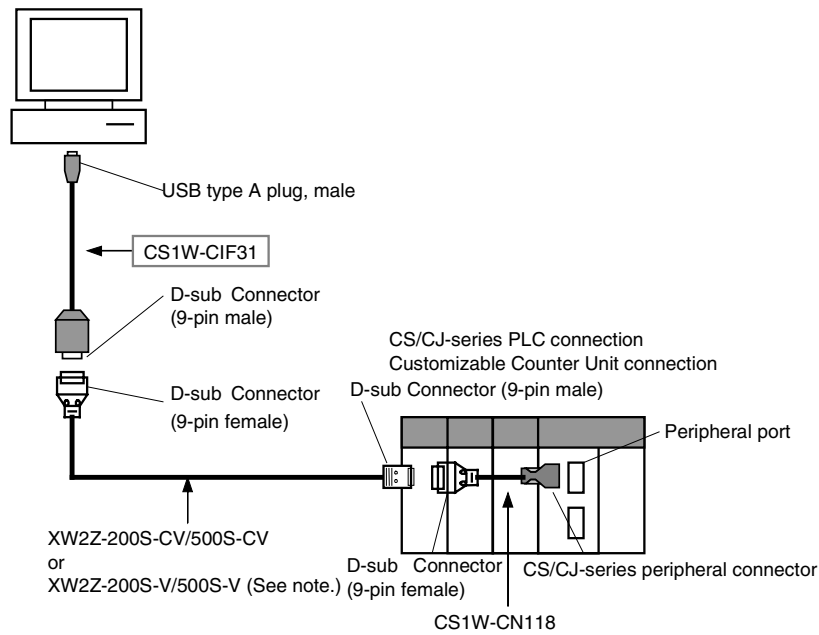

Note: With a CS/CJ-series PLC, the connection must be a host link connection.

- Connecting to the RS-232C Port

- Using a XW2Z-200S-CV/500S-CV or XW2Z-200S-V/500S-V Cable for an RS-232C Connection

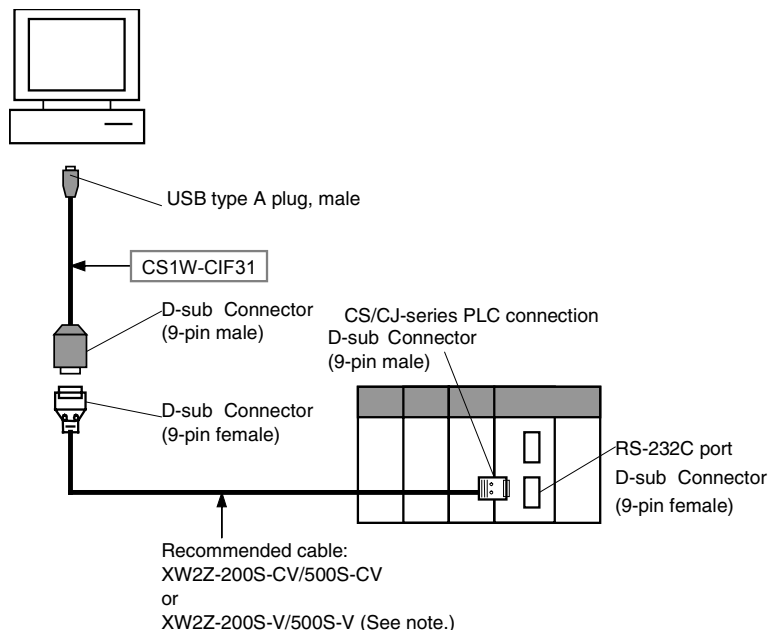

Note: With a CS/CJ-series PLC, the connection must be a host link connection.

C-series PLCs

■ C200HS, C200HX/HG/HE, C200H, C1000H, C2000H, CQM1, CPM1, CPM1A, CPM2A, or SRM1

• Connecting to the Peripheral Port

Using a CQM1-CIF02 Cable

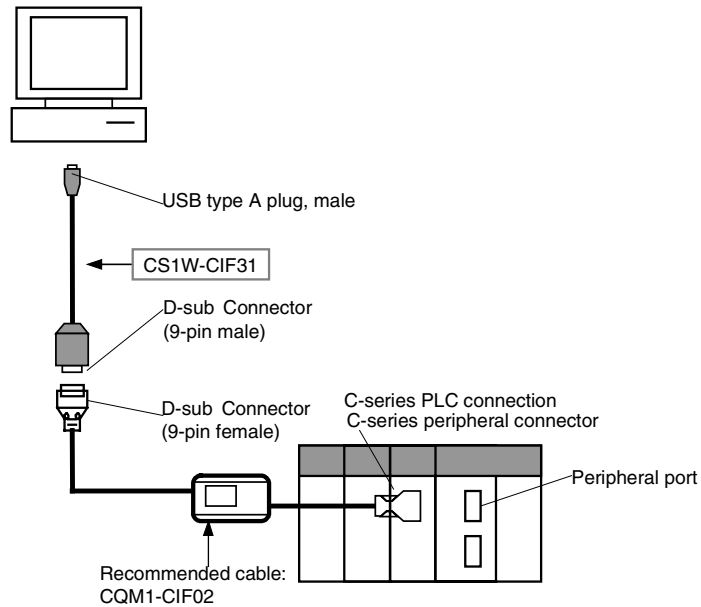

• Connecting to the RS-232C Port

Using a XW2Z-200S-CV/500S-CV or XW2Z-200S-V/500S-V Cable for an RS-232C Connection

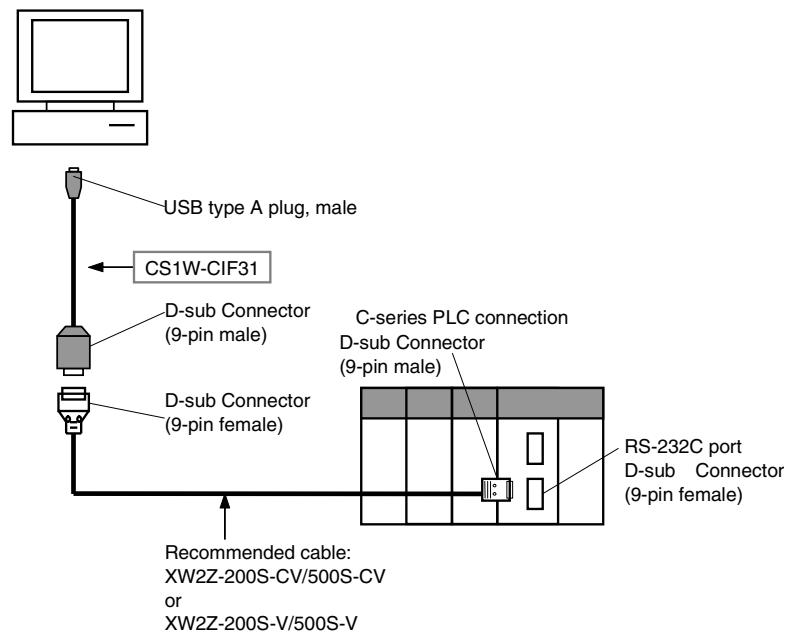

■ CQM1H and CPM2C PLCs

• Connecting to the Peripheral Port

Using a CS1W-CN226/626 Cable

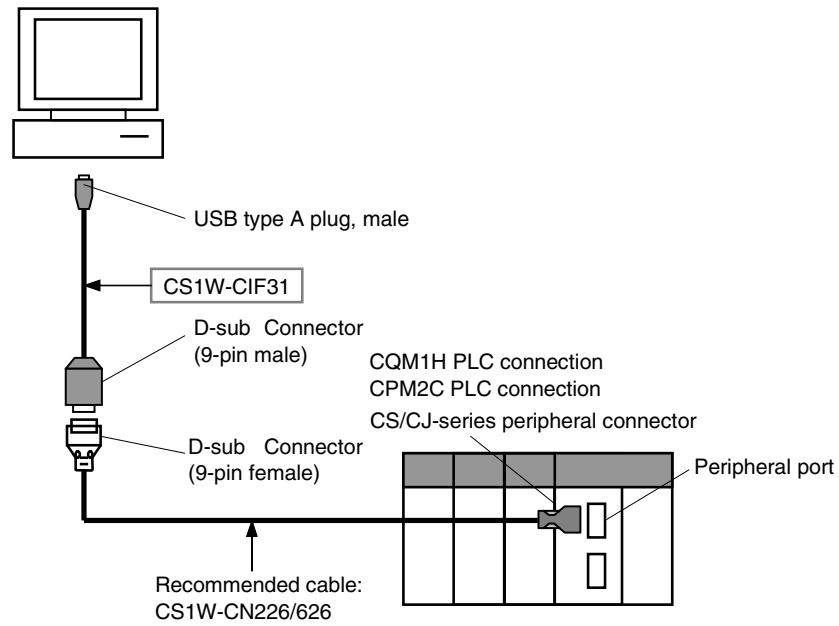

Using a CQM1-CIF02 Cable

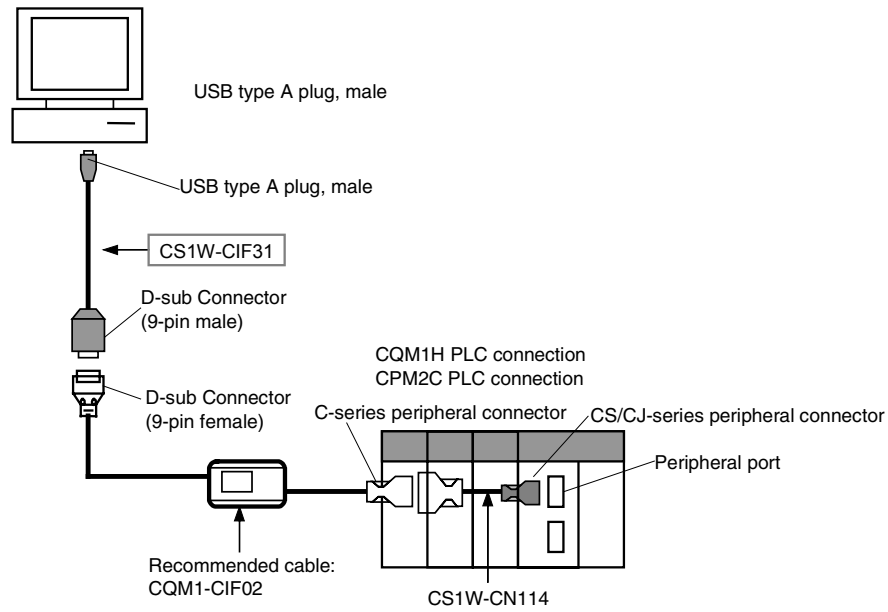

Note: With a CS/CJ-series PLC, the connection must be a host link connection.

Using a XW2Z-200S-CV/500S-CV or XW2Z-200S-V/500S-V Cable for an RS-232C Connection

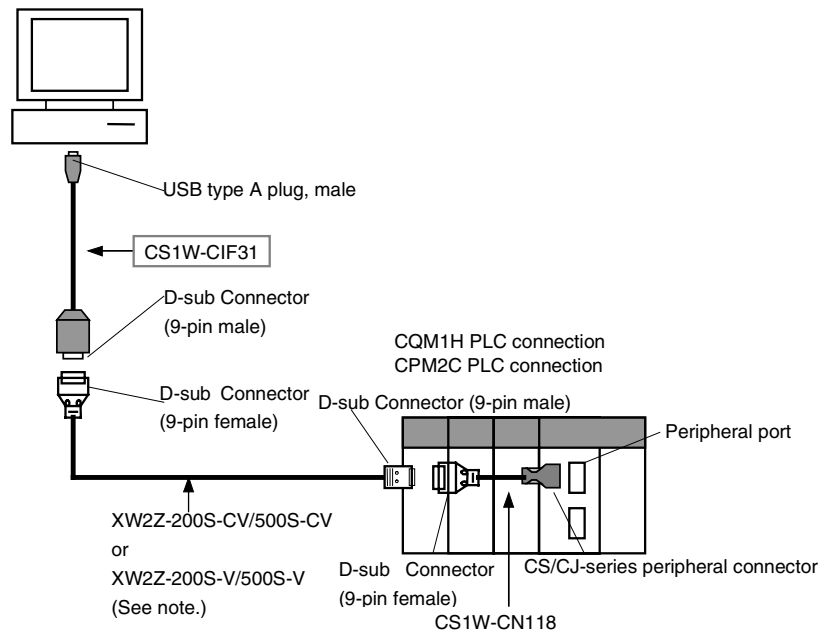

Note: With a CS/CJ-series PLC, the connection must be a host link connection.

• **Connecting to the RS-232C Port**

Using a XW2Z-200S-CV/500S-CV or XW2Z-200S-V/500S-V Cable for an RS-232C Connection

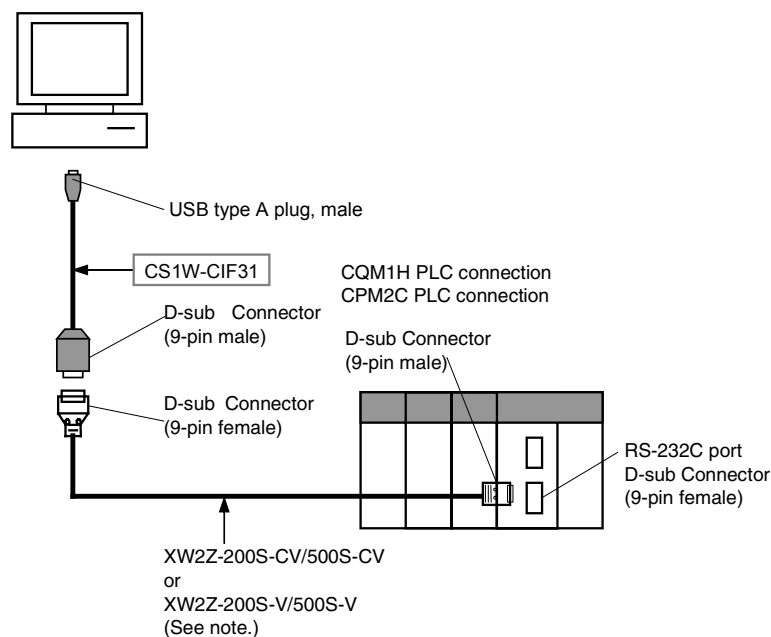

Note: With a CS/CJ-series PLC, the connection must be a host link connection.

CVM1 and CV-series PLCs

• Connecting to the Peripheral Port

• Using a CV500-CIF01 Cable

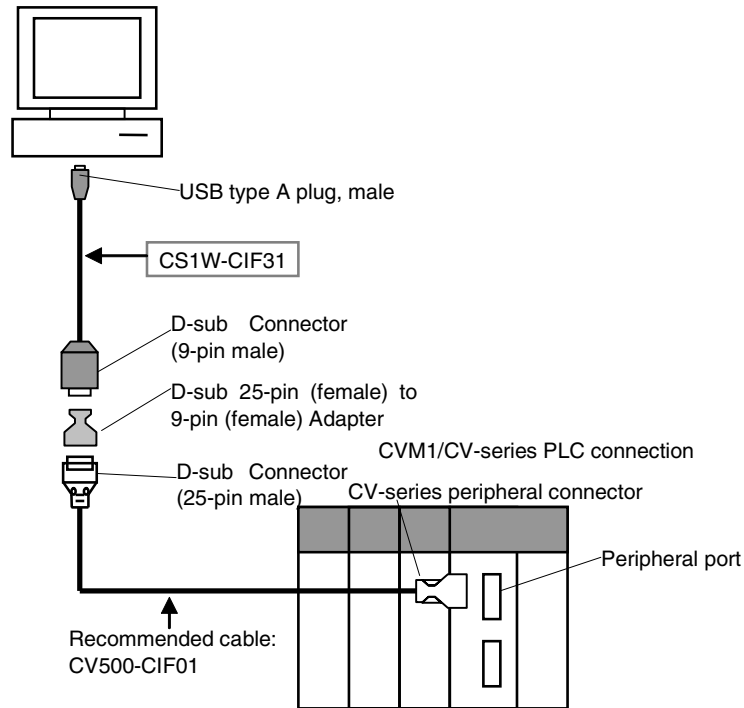

• Connecting to the RS-232C Port

• Using a XW2Z-200S-V/500S-V Cable

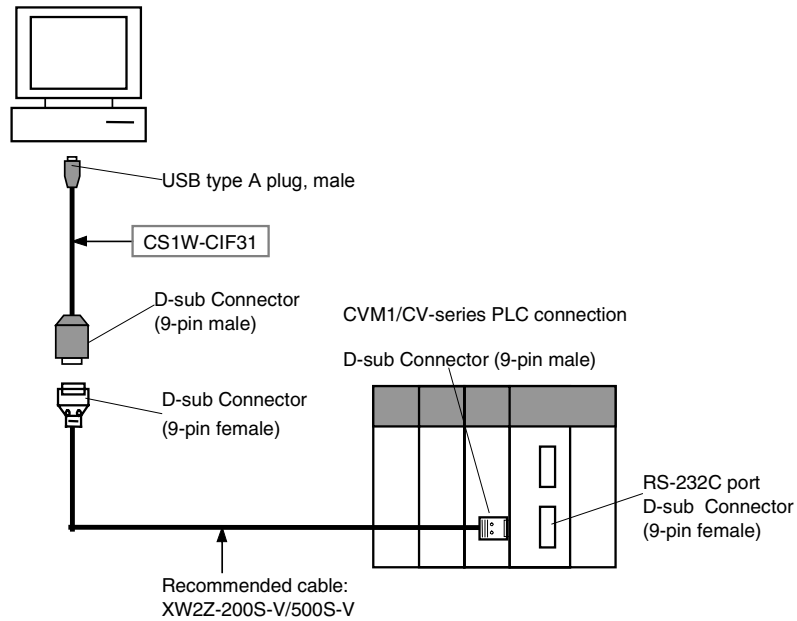

PTs (NS and NT Series)

- Connecting to the RS-232C Port
- Using a XW2Z-S002 Cable

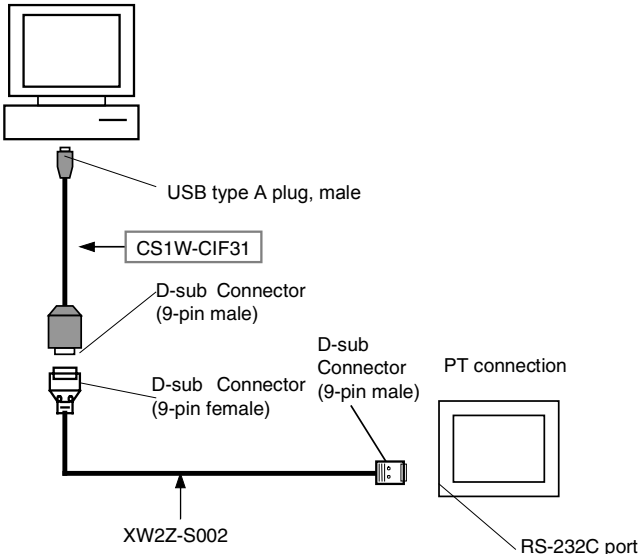

Programmable Relay (ZEN)

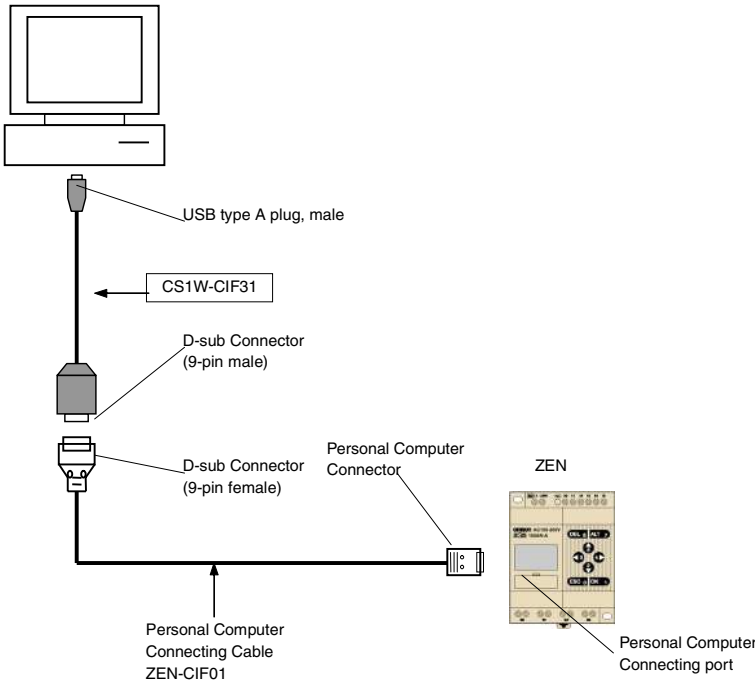

USB to PLC/PT Connection Tables

Connecting with the CS1W-CIF31 (D-sub Connector Cable)

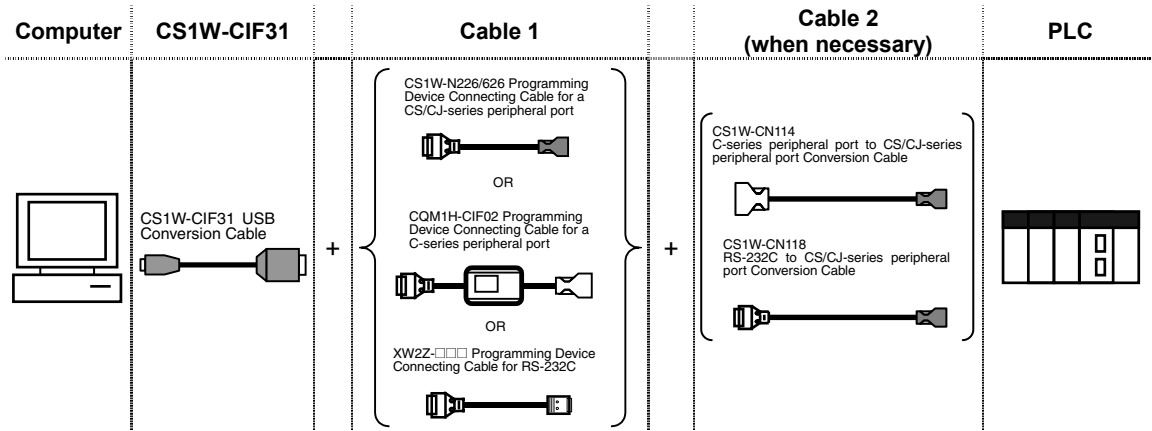

CS/CJ-series Units

• CS/CJ-series CPU Units

USB Conversion Cable	Cable 1			Cable 2			Unit's port	Serial communications mode (Network type)
	Model	Connector	Model	Connector	Model	Connector		
CS1W-CIF31	D-sub 9-pin, female	CS1W-CN226/626 (Length: 2 or 6 m)	CS/CJ-series peripheral	Not necessary			CS/CJ-series peripheral	Peripheral bus (Toolbus) or Host link (SYSWAY)
	D-sub 9-pin, female	CQM1-CIF02 (Length: 3.3 m)	C-series peripheral	C-series peripheral	CS1W-CN114 (Length: 5 cm)	CS/CJ-series peripheral		Host link (SYSWAY)
	D-sub 9-pin, female	XW2Z-200S-CV /500S-CV (Length: 2 or 5 m)	D-sub 9-pin, male	D-sub 9-pin, female	CS1W-CN118 (Length: 0.1 m)	CS/CJ-series peripheral	Peripheral bus (Toolbus) or Host link (SYSWAY)	
	D-sub 9-pin, female	XW2Z-200S-V /500S-V (Length: 2 or 5 m)	D-sub 9-pin, male	D-sub 9-pin, female	CS1W-CN118 (Length: 0.1 m)	CS/CJ-series peripheral	Host link (SYSWAY)	
	D-sub 9-pin, female	XW2Z-200S-CV /500S-CV (Length: 2 or 5 m)	RS-232C D-sub 9-pin, male	Not necessary			RS-232C D-sub 9-pin, female	Peripheral bus (Toolbus) or Host link (SYSWAY)
	D-sub 9-pin, female	XW2Z-200S-V /500S-V (Length: 2 or 5 m)	RS-232C D-sub 9-pin, male	Not necessary				Host link (SYSWAY)

USB to PLC/PT Connection Tables

● CS/CJ-series Serial Communications Board or Unit

USB Conversion Cable	Cable 1			Cable 2			Unit's port	Serial communications mode (Network type)
	Model	Connector	Model	Connector	Connector	Model		
CS1W-CIF31	D-sub 9-pin, female	XW2Z-200S-CV /500S-CV (Length: 2 or 5 m)	RS-232C D-sub 9-pin, male	Not necessary			RS-232C D-sub 9-pin, female	Host link (SYSWAY)
	D-sub 9-pin, female	XW2Z-200S-V /500S-V (Length: 2 or 5 m)	RS-232C D-sub 9-pin, male	Not necessary				

● Customizable Counter Unit

USB Conversion Cable	Cable 1			Cable 2			Unit's port	Serial communications mode (Network type)
	Model	Connector	Model	Connector	Connector	Model		
CS1W-CIF31	D-sub 9-pin, female	CS1W-CN226/626 (Length: 2 or 6 m)	CS/CJ-series peripheral	Not necessary			CS/CJ-series peripheral	Peripheral bus (Toolbus)
	D-sub 9-pin, female	XW2Z-200S-V /500S-V (Length: 2 or 5 m)	D-sub 9-pin, male	D-sub 9-pin, female	CS1W-CN118 (Length: 0.1 m)	CS/CJ-series peripheral		Peripheral bus (Toolbus)

■ C-series Units

Note: In this table, the C-series refers to the C200HS, C200HX/HG/HE, C200H, C1000H, C2000H, CQM1, CPM1, CPM1A, CPM2A, SRM1, CQM1H, and CPM2C.

● C200HS, C200HX/HG/HE, CQM1, CPM1, CPM1A, CPM2A, and SRM1

USB Conversion Cable	Cable 1			Cable 2			Unit's port	Serial communications mode (Network type)
	Model	Connector	Model	Connector	Connector	Model		
CS1W-CIF31	D-sub 9-pin, female	CQM1-CIF02 (Length: 3.3 m)	C-series peripheral	Not necessary			C-series peripheral	Peripheral bus (Toolbus) or Host link (SYSWAY) (See note.)
	D-sub 9-pin, female	XW2Z-200S-CV /500S-CV (Length: 2 or 5 m)	D-sub 9-pin, male	Not necessary				RS-232C D-sub 9-pin, female
	D-sub 9-pin, female	XW2Z-200S-V /500S-V (Length: 2 or 5 m)	D-sub 9-pin, male	Not necessary				

Note: The host link mode can be used in all of these PLCs, but the peripheral bus mode cannot be used in CPM2□ PLCs that have a 9 as the 4th digit of the lot number. (The lot number may be 4 or 5 digits long.)

● C200H, C1000H, and C2000H CPU Units

USB Conversion Cable	Cable 1			Cable 2			Unit's port	Serial communications mode (Network type)
	Model	Connector	Model	Connector	Connector	Model		
CS1W-CIF31	D-sub 9-pin, female	CQM1-CIF02 (Length: 3.3 m)	C-series peripheral	C-series peripheral	C200H-IP007	Built-in peripheral port	Host link (SYSWAY)	

USB to PLC/PT Connection Tables

● CQM1H CPU Units

USB Conversion Cable	Cable 1			Cable 2			Unit's port	Serial communications mode (Network type)
	Model	Connector	Model	Connector	Connector	Model		
CS1W-CIF31	D-sub 9-pin, female	CS1W-CN226/626 (Length: 2 or 6 m)	CS/CJ-series peripheral	Not necessary			CS/CJ-series peripheral	Peripheral bus (Toolbus) or Host link (SYSWAY)
	D-sub 9-pin, female	CQM1-CIF02 (Length: 3.3 m)	C-series peripheral	C-series peripheral	CS1W-CN114 (Length: 5 cm)	CS/CJ-series peripheral		
	D-sub 9-pin, female	XW2Z-200S-CV /500S-CV (Length: 2 or 5 m)	D-sub 9-pin, male	D-sub 9-pin, female	CS1W-CN118 (Length: 0.1 m)	CS/CJ-series peripheral		
	D-sub 9-pin, female	XW2Z-200S-V /500S-V (Length: 2 or 5 m)	D-sub 9-pin, male	D-sub 9-pin, female	CS1W-CN118 (Length: 0.1 m)	CS/CJ-series peripheral		
	D-sub 9-pin, female	XW2Z-200S-CV /500S-CV (Length: 2 or 5 m)	D-sub 9-pin, male	Not necessary			RS-232C D-sub 9-pin, female	Host link (SYSWAY)
	D-sub 9-pin, female	XW2Z-200S-V /500S-V (Length: 2 or 5 m)	D-sub 9-pin, male	Not necessary				

● CPM2C

USB Conversion Cable	Cable 1			Cable 2			Unit's port	Serial communications mode (Network type)
	Model	Connector	Model	Connector	Connector	Model		
CS1W-CIF31	D-sub 9-pin, female	CQM1-CIF02 (Length: 3.3 m)	C-series peripheral	C-series peripheral	CS1W-CN114 (Length: 5 cm)	CS/CJ-series peripheral	CS/CJ-series peripheral	Peripheral bus (Toolbus) or Host link (SYSWAY) (See note 1.)
	D-sub 9-pin, female	CQM1-CIF02 (Length: 3.3 m)	C-series peripheral	C-series peripheral	CPM2C-CN111 (Peripheral port connector)	CS/CJ-series peripheral		
	D-sub 9-pin, female	CS1W-CN226/626 (Length: 2 or 6 m) (See note 2.)	CS/CJ-series peripheral	Not necessary				
	D-sub 9-pin, female	XW2Z-200S-CV /500S-CV (Length: 2 or 5 m)	D-sub 9-pin, male	D-sub 9-pin, female	CS1W-CN118 (Length: 0.1 m)	CS/CJ-series peripheral		
	D-sub 9-pin, female	XW2Z-200S-CV /500S-CV (Length: 2 or 5 m)	D-sub 9-pin, male	D-sub 9-pin, female	CPM2C-CN111 (RS-232C port connector)	CS/CJ-series peripheral		
	D-sub 9-pin, female	XW2Z-200S-V /500S-V (Length: 2 or 5 m)	D-sub 9-pin, male	D-sub 9-pin, female	CS1W-CN118 (Length: 0.1 m)	CS/CJ-series peripheral		
	D-sub 9-pin, female	XW2Z-200S-V /500S-V (Length: 2 or 5 m)	D-sub 9-pin, male	D-sub 9-pin, female	CPM2C-CN111 (RS-232C port connector)	CS/CJ-series peripheral		

Note 1: The host link mode can be used in all of these PLCs, but the peripheral bus mode cannot be used in CPM2□ PLCs that have a 9 as the 4th digit of the lot number. (The lot number may be 4 or 5 digits long.)

Note 2: Only host link mode can be used.

USB to PLC/PT Connection Tables

● C-series Host Link Unit (C200H-LK201-V1 or C120-LK201-V1)

Note: The Host Link Unit cannot be used to connect a Programming Device (such as the CX-Programmer) to a C200HX/HG/HE with the "-ZE" suffix at the end of the model number.

USB Conversion Cable	Cable 1			Cable 2			Unit's port	Serial communications mode (Network type)
	Model	Connector	Model	Connector	Connector	Model		
CS1W-CIF31	D-sub 9-pin, female	XW2Z-200P-V (Length: 2 or 5 m)	D-sub 25-pin, male	Not necessary			RS-232C D-sub 25-pin, female	Host link (SYSWAY)

● C-series Communications Board (C200HX/HG/HE PLCs Only)

USB Conversion Cable	Cable 1			Cable 2			Unit's port	Serial communications mode (Network type)
	Model	Connector	Model	Connector	Connector	Model		
CS1W-CIF31	D-sub 9-pin, female	XW2Z-200S-CV (Length: 2 or 5 m)	D-sub 9-pin, male	Not necessary			RS-232C D-sub 9-pin, female	Host link (SYSWAY)
	D-sub 9-pin, female	XW2Z-200S-V (Length: 2 or 5 m)	D-sub 9-pin, male	Not necessary				

● C200H, C1000H, and C2000H Host Link Units

Note: The C500-LK203 and C500-LK 201-V1 Host Link Units can be used with the C1000H and C2000H. The C200H-LK201-V1 and C120-LK201-V1 Host Link Units can be used with the C200H.

USB Conversion Cable	Cable 1			Cable 2			Unit's port	Serial communications mode (Network type)
	Model	Connector	Model	Connector	Connector	Model		
CS1W-CIF31	D-sub 9-pin, female	XW2Z-200P-V (Length: 2 or 5 m)	D-sub 25-pin, male	Not necessary			RS-232C D-sub 25-pin, female	Host link (SYSWAY)

● CQM1H Serial Communication Board

USB Conversion Cable	Cable 1			Cable 2			Unit's port	Serial communications mode (Network type)
	Model	Connector	Model	Connector	Connector	Model		
CS1W-CIF31	D-sub 9-pin, female	XW2Z-200S-CV (Length: 2 or 5 m)	D-sub 9-pin, male	Not necessary			RS-232C D-sub 9-pin, female	Host link (SYSWAY)
	D-sub 9-pin, female	XW2Z-200S-V (Length: 2 or 5 m)	D-sub 9-pin, male	Not necessary				

USB to PLC/PT Connection Tables

■ CVM1 and CV-series

● CVM1 and CV-series CPU Units

USB Conversion Cable	Cable 1			Cable 2			Unit's port	Serial communications mode (Network type)
	Model	Connector	Model	Connector	Connector	Model		
CS1W-CIF31	D-sub 9-pin, female	D-sub 25-pin (female) to D-sub 9-pin (female) adapter	D-sub 25-pin, male	D-sub 25-pin, female	CV500-CIF01 (Length: 6 m)	CV-series peripheral	CV-series peripheral	Peripheral bus (Toolbus)
	D-sub 9-pin, female	XW2Z-200S-V /500S-V (Length: 2 or 5 m)	D-sub 9-pin, male	Not necessary			RS-232C D-sub 9-pin, female	Host link (SYSWAY)

● CVM1 and CV-series Host Link Units

● CV500-LK201 (Port 1, Full-duplex mode)

USB Conversion Cable	Cable 1			Cable 2			Unit's port	Serial communications mode (Network type)
	Model	Connector	Model	Connector	Connector	Model		
CS1W-CIF31	D-sub 9-pin, female	XW2Z-200P-V /500P-V (Length: 2 or 5 m)	D-sub 25-pin, male	Not necessary			RS-232C D-sub 25-pin, female	Host link (SYSWAY)

● CV500-LK201 (Port 2, Full-duplex mode)

USB Conversion Cable	Cable 1			Cable 2			Unit's port	Serial communications mode (Network type)
	Model	Connector	Model	Connector	Connector	Model		
CS1W-CIF31	D-sub 9-pin, female	XW2Z-200S-V /500S-V (Length: 2 or 5 m)	D-sub 9-pin, male	Not necessary			RS-232C D-sub 9-pin, female	Host link (SYSWAY)

■ PTs (NS or NT Series)

USB Conversion Cable	Cable 1			Cable 2			Unit's port	Serial communications mode (Network type)
	Model	Connector	Model	Connector	Connector	Model		
CS1W-CIF31	D-sub 9-pin, female	XW2Z-S002 (Length: 2 m)	D-sub 9-pin, male	Not necessary			RS-232C D-sub 9-pin, female	Host link (SYSWAY)

■ Programmable Relay (ZEN)

USB Conversion Cable	Cable 1			Cable 2			Unit's port	Serial communications mode (Network type)
	Model	Connector	Model	Connector	Connector	Model		
CS1W-CIF31	D-sub 9-pin, female	ZEN-CIF01 (Length: 2 m)	Personal Computer Connector	Not necessary			Personal Computer port	

Application Procedure

This section explains how to connect a PLC CPU Unit to a personal computer with a USB-Serial Conversion Cable. Use the procedure below when connecting a PLC CPU Unit and personal computer.

The Conversion Cable uses one of the computer's COM ports for communications. When communicating with a PLC through a Conversion Cable, set the communications port (COM port) number used by the software to the communications port (COM port) number allocated to the Conversion Cable.

1. Connect the Cable(s).

Connect the Conversion Cable to the computer's USB port and the CPU Unit's peripheral port or RS-232C port.

For details, refer to *Connecting the Cable* on page 28.

2. Install the communications driver.

The Conversion Cable's communications driver must be installed in the computer in order for the computer to use the Conversion Cable.

For details, refer to *Installing the Driver* on page 29.

3. Turn ON the PLC's power.

Turn ON the PLC's power supply.

4. Make an online connection to the CPU Unit through the computer software (when using the CX-Programmer.)

Select the COM port in the CPU Unit from the CX-Programmer and connect online.

For details, refer to *Connecting Online from the CX-Programmer* on page 34.

Note

More than one USB-Serial Conversion Cable can be used at a time, so a single personal computer can be connected to several PLCs/PTs through two or more COM ports.

When more than one Conversion Cable is being used, connect the second and later Cables after the first Cable has been connected.

The communications driver is automatically installed for the second and later Cables, so it is not necessary to install the driver a second time. Each Cable must have its own unique COM port number. Allocate a different COM port to each Cable.

Cable Connections

Connecting the Cable

Connect the computer and CPU Unit with one of the cable configurations shown in the *USB to PLC/PT Connection Tables* on page 22.

Installing the Drivers

When the USB-Serial Conversion Cable is connected to the computer, the operating system (OS) will recognize the Cable as a new device. At this point, the driver can be installed with the wizard.

The actual driver installation method depends on the OS being used. Windows 2000 is used in the examples in this section.

Note The USB-Serial Conversion Cables are compatible with Windows XP. When you install the Conversion Cable's driver, a warning message will appear indicating that the driver software has not passed Windows Logo testing, but click **Continue Anyway** to proceed with the installation. We have thoroughly tested the driver on Windows XP and verified that it operates properly. The driver will not be installed properly if the installation process is cancelled before completion. Normal communications may not be possible if the driver is not installed properly. If the driver is not installed properly, uninstall it (refer to page 33) and then reinstall it correctly.

Note The USB-Serial Conversion Cables are compatible with Windows Vista. When you install the Conversion Cable's driver, a warning message will appear indicating that Windows can't verify the publisher of this driver software, but click **Continue Anyway** to proceed with the installation. We have thoroughly tested the driver on Windows Vista and verified that it operates properly. The driver will not be installed properly if the installation process is cancelled before completion. Normal communications may not be possible if the driver is not installed properly. If the driver is not installed properly, uninstall it (refer to page 33) and then reinstall it correctly.

1. The following window will be displayed.

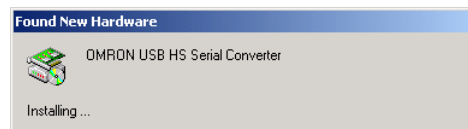

2. The following window will be displayed. Click the **Next** button.



The following window will be displayed.

Installing the Drivers



3. Select *Search for a suitable driver for my device (recommended)* and click the **Next** button.

The following window will be displayed.

Select *Specify a location* and click the **Next** button.

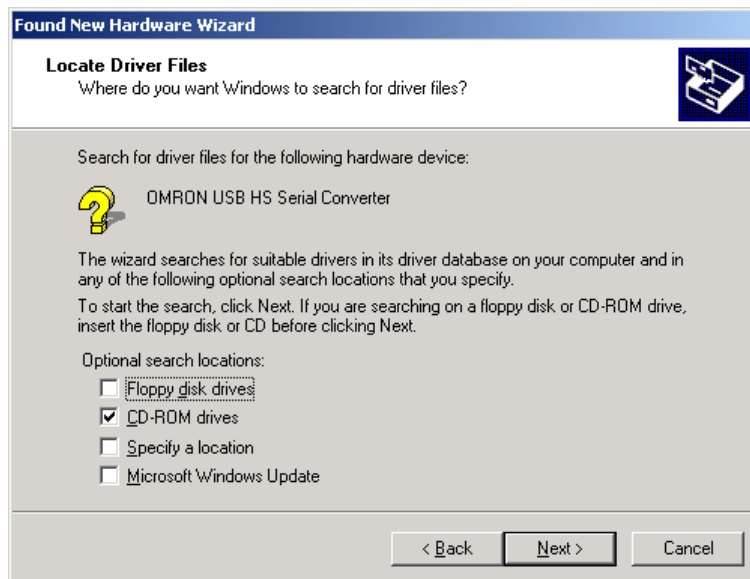

The following window will be displayed.



4. Insert the CD-ROM containing the driver (the CD-ROM is in the same package as the Conversion Cable) into the computer's CD-ROM drive. Click the **Browse** button, select the *ftdibus.inf* file, from the following directory of the CD-ROM and click the **OK** button.

Windows2000/XP/Vista: *win2000_XP*

Windows98/Me: *win98_Me*

If the window's *Copy manufacturer's files from* field shows the correct folder, click the **OK** button.

5. The following window will be displayed. Click the **Next** button to start the installing the driver.

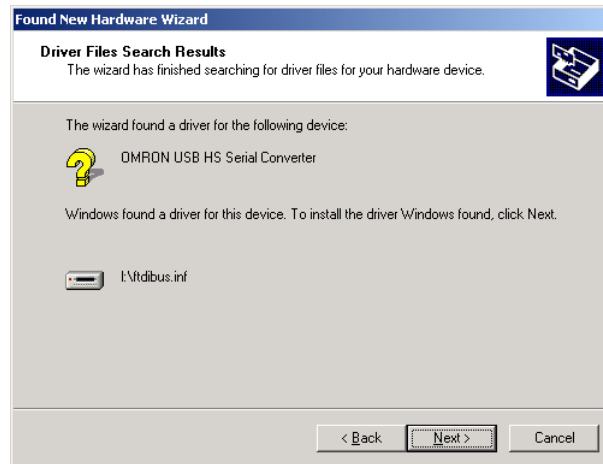

6. The following window will be displayed if the driver was installed properly. Click the **Finish** button.

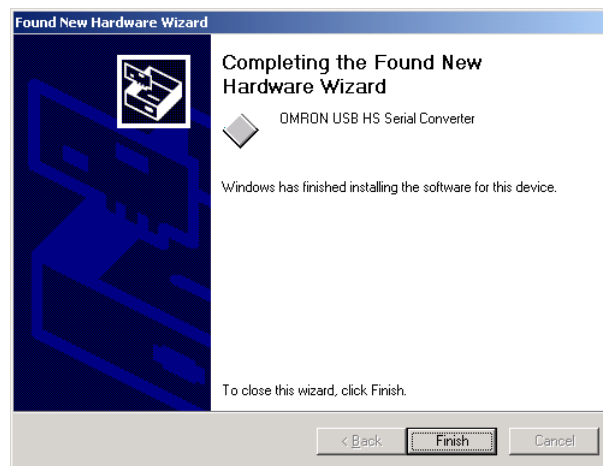

7. When the **Finish** button is clicked in step 6, the following window will be displayed for installation of the USB Serial Port driver.

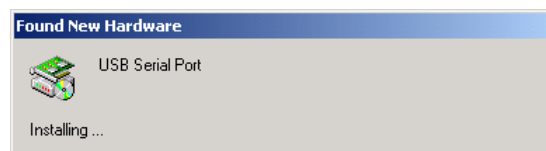

Follow the same procedure in steps 1 through 7 to install the USB Serial Port driver. (Driver installation is completed after installation of the USB Serial Port driver.)

8. Verify that the drivers were installed properly with the Windows Device Manager, as shown in the following diagram. To access the Device Manager, open the *Control Panel*, open the *System* folder, click the **Hardware** tab, and click the **Device Manager** button.

Installing the Drivers

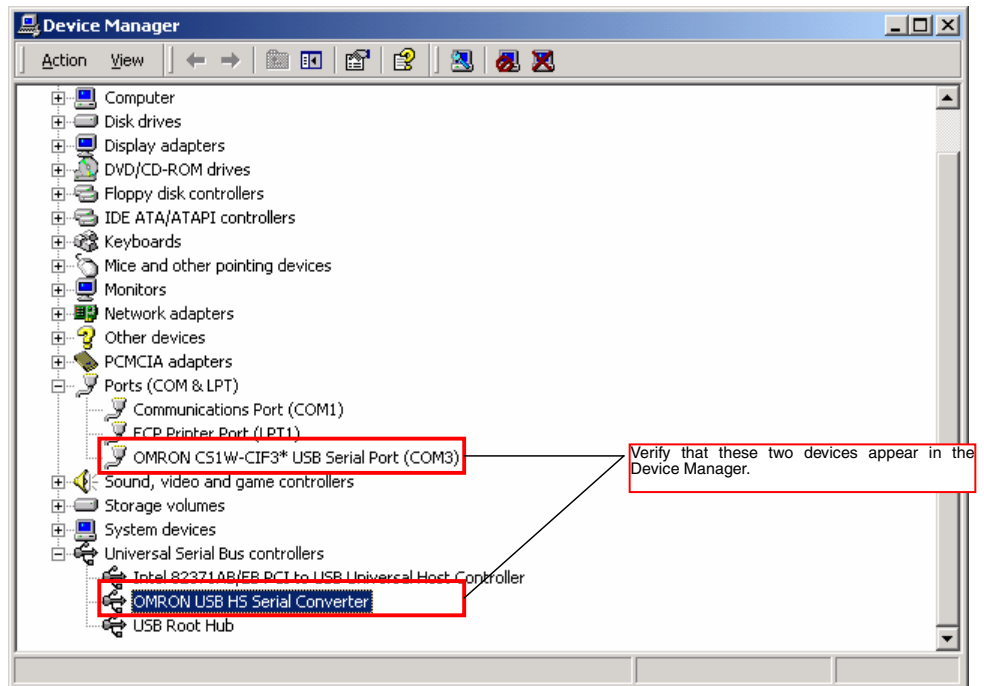

Uninstalling the Drivers

Use the following procedure to delete (uninstall) the drivers for the USB-Serial Conversion Cable.

1. Disconnect the Conversion Cable from the computer.
2. Select *Add/Remove Programs* from the *Control Panel*.

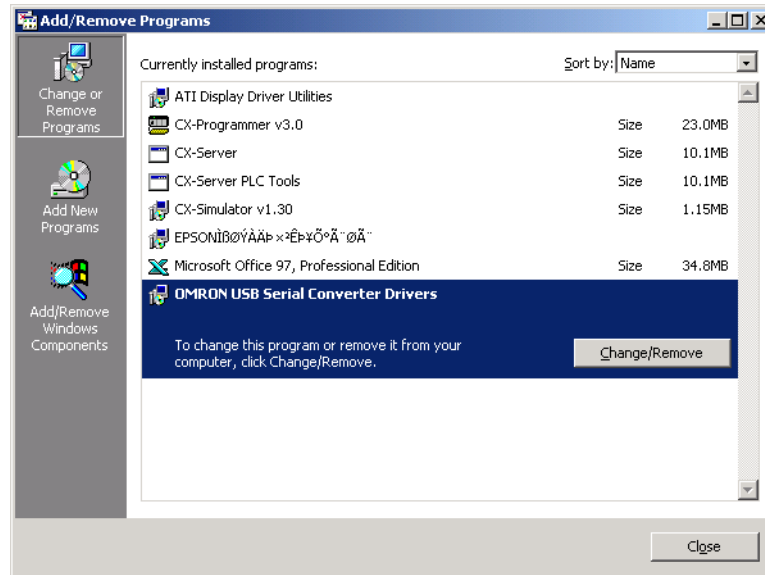

3. Select *OMRON USB-to-Serial Converter Drivers* and click the **Delete** button. The following window will be displayed.

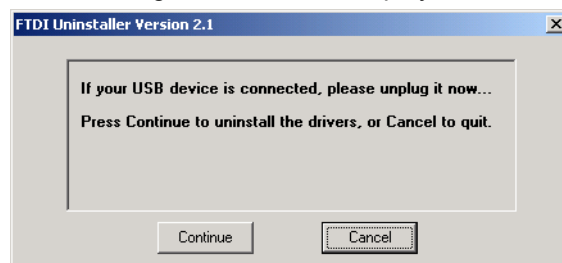

4. Click the **Continue** button. When the drivers have been successfully deleted, the message *Uninstall complete, press Finish to exit* will be displayed.

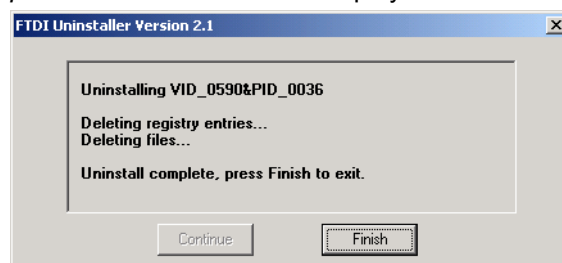

5. Click the **Finish** button.

This completes the deletion (uninstallation) of the Conversion Cable's drivers.

Connecting Online from the CX-Programmer

The USB-Serial Conversion Cable uses one of the computer's COM ports to communicate. The communications port (COM port) allocated to the Conversion Cable must be selected with the CX-Programmer in order to connect online to a PLC or PT.

Note: It may take some time for the computer to detect the cable after the cable is connected. This is not a malfunction.

■ Selecting the Cable's COM Port in CX-Programmer

Use the following procedure to select the COM port used by the Conversion Cable.

1. Display the *Change PLC* dialog box.

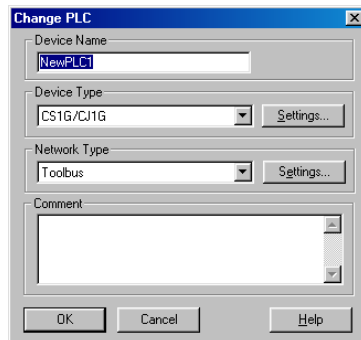

2. Click the **Settings** button in the *Network Type* area. Select the desired type of network.

The *Network Settings* dialog box will be displayed.

3. Click the **Driver** tab in the *Network Settings* dialog box.

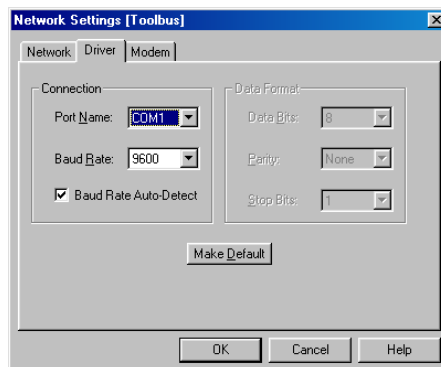

4. Locate the *Port Name* setting and select the COM port being used by the Conversion Cable.

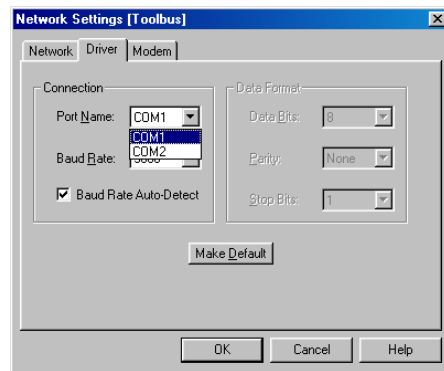

Note If you fail to connect with this USB Cable, turn OFF auto baud rate detection if it is being used by your software. With the CX-Programmer, auto baud rate detection can be turned OFF by clearing the selection for it on the *Network Settings* dialog box.

■ Verifying the Allocated Communications Port

The communications port (COM port) being used by the Conversion Cable can be verified with the following procedure. The actual verification procedure depends on the operating system. This example shows the procedure for Windows 2000.

1. Open the *Control Panel*, open the *System* folder, and click the **Hardware** tab.
2. Click the **Device Manager** button.
3. Click the + symbol to the left of the *Ports (COM & LPT)* device icon to display the contents of that folder. Verify that there is an entry for the *OMRON CS1W-CIF3* USB Serial Port (COM3)* device.

A communications port name will appear in parentheses. This is the communications port being used by the Conversion Cable.

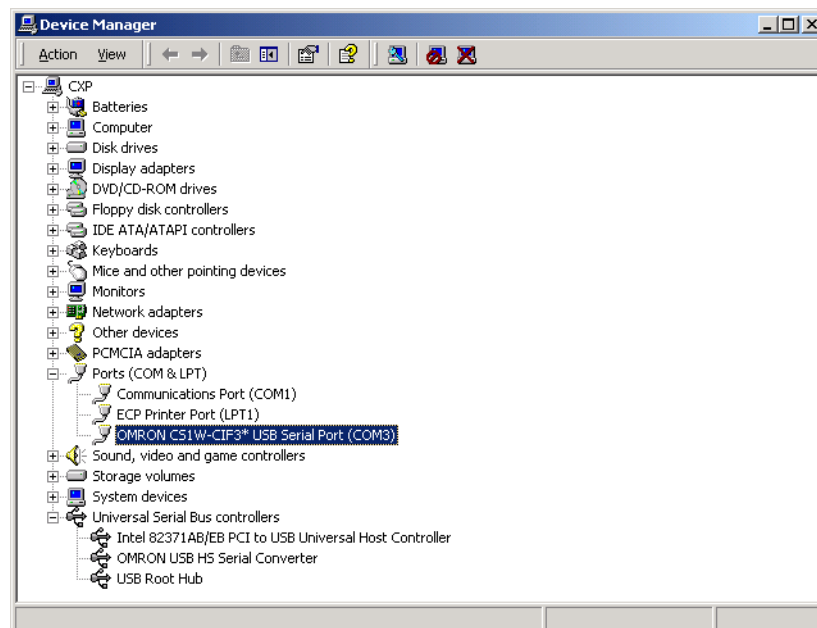

■ Changing the Allocated Communications Port

The communications port (COM port) being used by the Conversion Cable can be changed with the following procedure. The actual change procedure depends on the operating system. This example shows the procedure for Windows 2000.

Note If the new COM port is being used by another driver, that driver must be uninstalled.

1. Double-click *OMRON CS1W-CIF3* USB Serial Port (COM3)* in the Device Manager window.

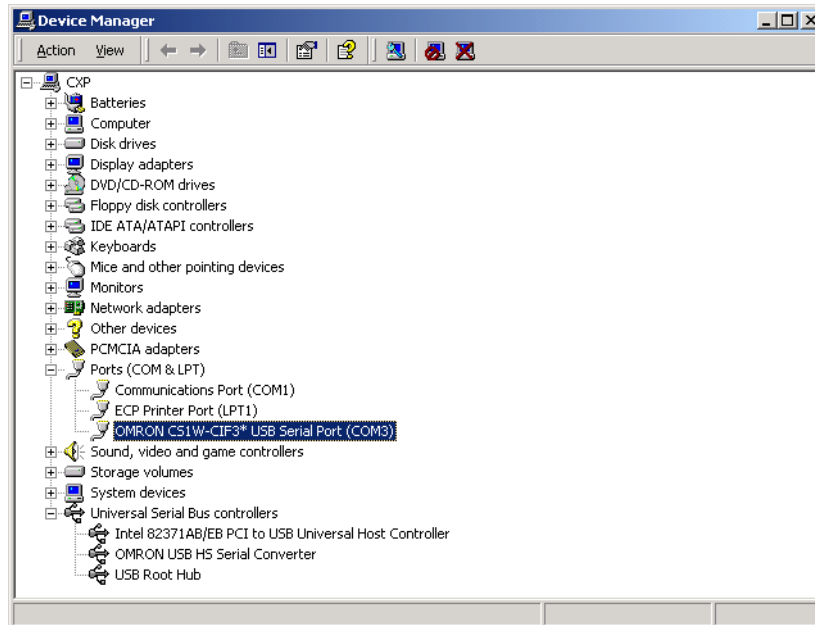

2. Click the **Port Settings** tab.

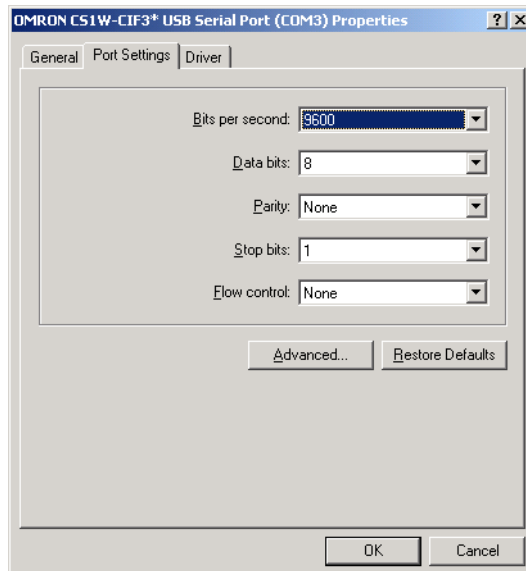

Connecting Online from the CX-Programmer

3. Click the **Advanced** button. The following window will be displayed.

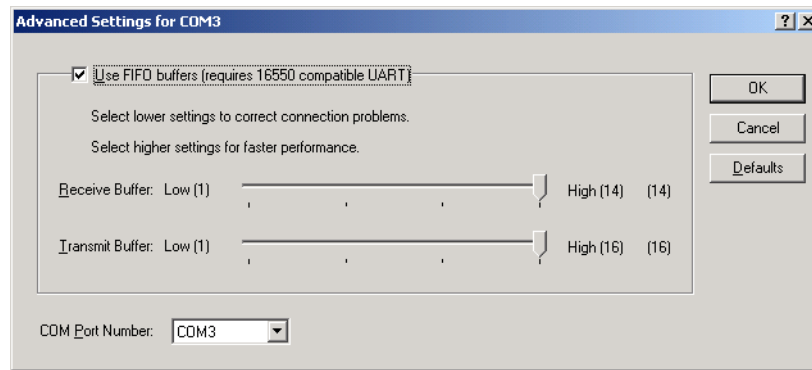

4. Select the new COM port number from the *COM Port Number* list.
5. Click the **OK** button to change the COM port used by the Conversion Cable.

Using More than One Conversion Cable

The operating system recognizes USB-Serial Conversion Cables individually. If a second Conversion Cable is connected after the driver has been installed, driver installation will be requested again. Install the driver from the CD-ROM again.

If you do not own the CD-ROM and will use more than one Conversion Cable, copy the *win2000_XP* folder from the CD-ROM to a folder on your hard disk, and select this folder.

Note: Use the following directory for Windows 98 or Me: **Win98_Me**

1. Copy the *win2000_XP* folder from the CD-ROM to your hard disk (the CD-ROM is in the same package as the Conversion Cable).
2. The following window will be displayed. Select *Install from a list or specific location (Advanced)* and click the **Next** button.



3. Click the **Browse** button next to the *Include this location in the search* field, select the *win2000_XP* folder copied from CD-ROM onto your hard disk, and click the **Next** button.

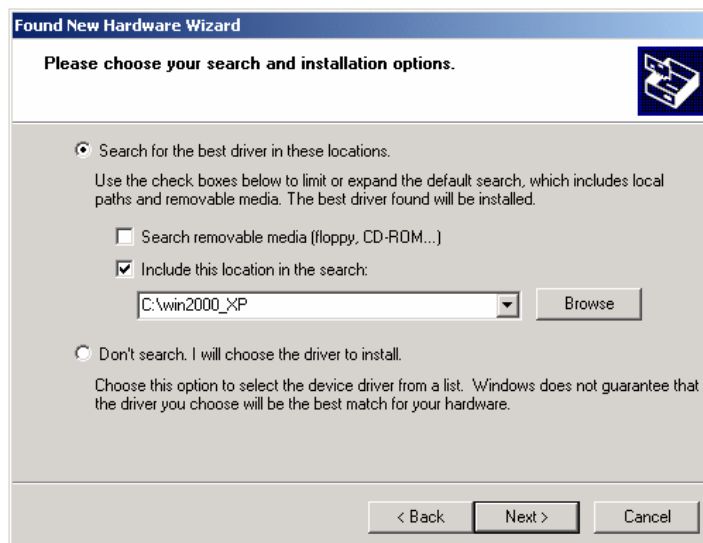

Revision History

A manual revision code appears as a suffix to the catalog number on the front cover of the manual.

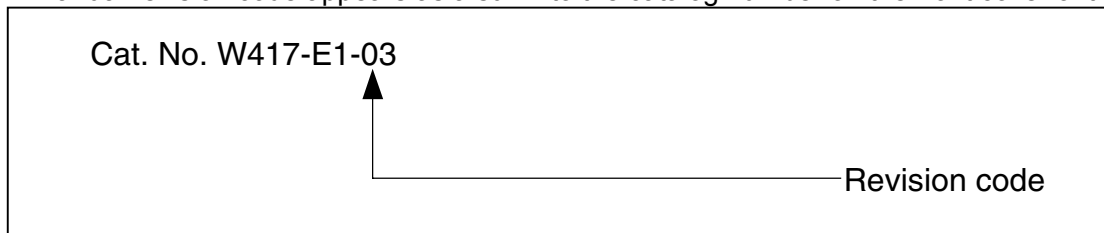

The following table outlines the changes made to the manual during each revision. Page numbers refer to the previous version.

Revision code	Date	Revised content
01	February 2003	Original production
02	October 2006	<p>Page 7: Changed EMI standard number of EC Directives.</p> <p>Page 30: Changed the reference directory for the driver file.</p> <p>Page 37: Add section on using more than one Conversion Cable.</p>
03	July 2007	<p>Page 10: Changed the compatible operating systems.</p> <p>Page 29: Changed information on installing the drivers.</p>

Index

C

communications port	
changing.....	36
verifying.....	35
component names.....	8
configuration, PLC/PT connections	
C200HS, C200HX/HG/HE, C200H, C1000H/2000H, CQM1, CPM1, CPM1A, CPM2A, and SRM1.....	17
CQM1H, CPM2C.....	18
CS/CJ-series PLCs.....	15
C-series PLCs.....	17
CVM1 and CV-series PLCs.....	20
NS-series and NT-series PTs.....	21
Programmable Relay (ZEN).....	21
CX-Programmer	
communications port.....	34

D

dimensions.....	14
drivers	
installing.....	29
uninstalling.....	33, 38

O

operating system, applicable.....	10
overview.....	8

P

PLCs, applicable.....	11
PTs, applicable.....	11

S

software, applicable.....	10
---------------------------	----

OMRON Corporation

Control Devices Division H.Q.

Shiokoji Horikawa, Shimogyo-ku,
Kyoto, 600-8530 Japan

Tel: (81)75-344-7109/Fax: (81)75-344-7149

Regional Headquarters

OMRON EUROPE B.V.

Wegalaan 67-69, NL-2132 JD Hoofddorp
The Netherlands

Tel: (31)2356-81-300/Fax: (31)2356-81-388

OMRON ELECTRONICS LLC

One Commerce Drive Schaumburg,
IL 60173-5302 U.S.A.

Tel: (1) 847-843-7900/Fax: (1) 847-843-7787

OMRON ASIA PACIFIC PTE. LTD.

No. 438A Alexandra Road # 05-05/08 (Lobby 2),
Alexandra Technopark, Singapore 119967

Tel: (65) 6835-3011/Fax: (65) 6835-2711

OMRON (CHINA) CO., LTD.

Room 2211, Bank of China Tower,
200 Yin Cheng Zhong Road,
Pu Dong New Area, Shanghai, 200120, China

Tel: (86) 21-5037-2222/Fax: (86) 21-5037-2200

OMRON

Authorized Distributor: