

Fits 120mm (4.724") X 55.5mm (2.185") PCB  
Note: Aluminum extrusion has a tolerance of +/- .02"

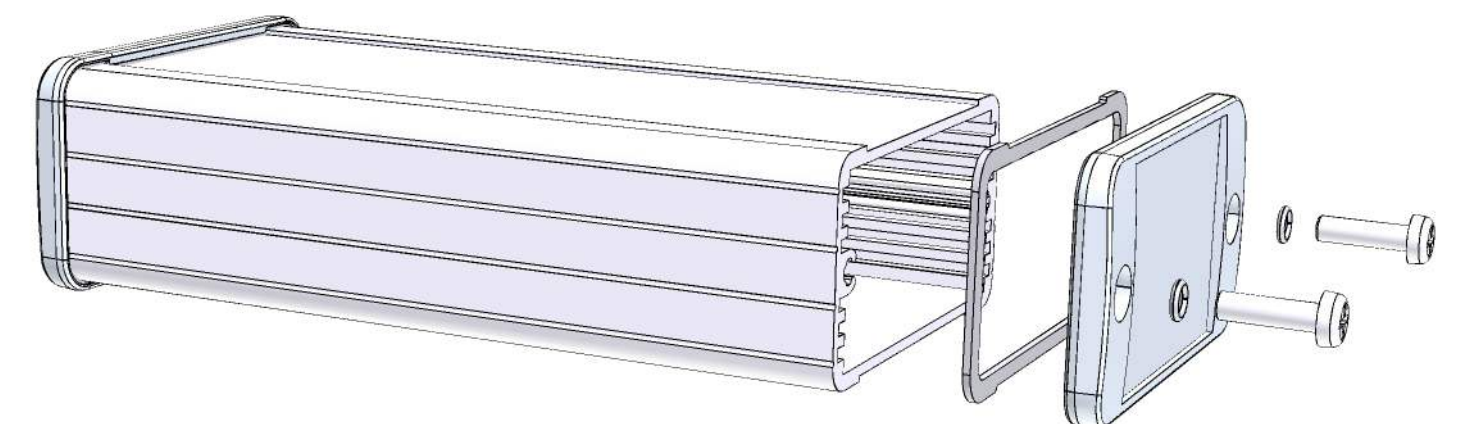

**PROTECTION TO IP 65**  
Enclosures can be Factory Modified ( Milling, Drilling, Printing etc. )  
Contact Factory [mjm@hammondmfg.com](mailto:mjm@hammondmfg.com) for quotes  
Solid models of this enclosure available in STEP or IGES.

NOTE	
Purchased assembly includes box, end panels, stainless steel #6 Taptight screws, self adhesive rubber feet, gaskets and O-Rings.	
Box made from Extruded Aluminum 6063.	
End panels made from Type 380 Diecast Aluminum with a black powder paint finish.	
WATERPROOF 1457C1201	
PART NUMBERS	
Clear anodized box with black powder painted end panels	1457C1201
Black powder painted box and end panels	1457C1201BK
EMI/RFI SHIELDED (IP 54)	
Clear anodized box with black powder painted end panels	1457C1201E
Black powder painted box and end panels	1457C1201EBK
ACCESSORIES	
See website for accessories.	

**HAMMOND MANUFACTURING™**

**1457C1201**  
[www.hammondmfg.com](http://www.hammondmfg.com)