

REV	ECN	APP'D
-	6215	JT 6/18/08
A	6299	JT 5-29-09

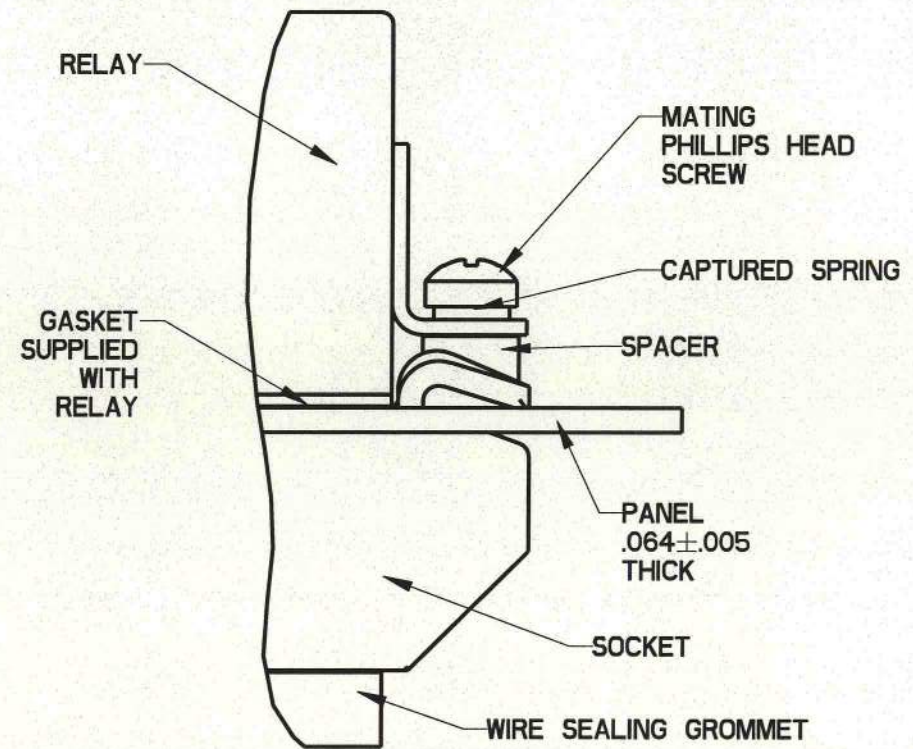
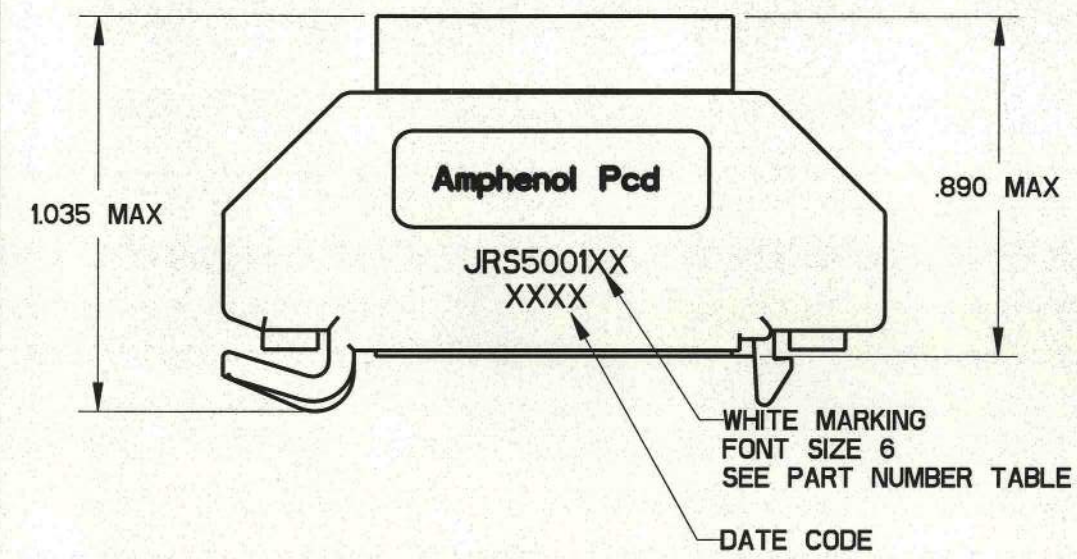
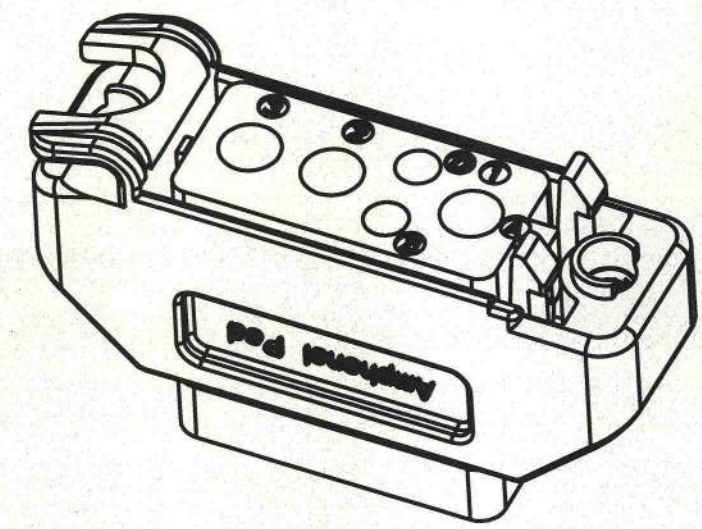
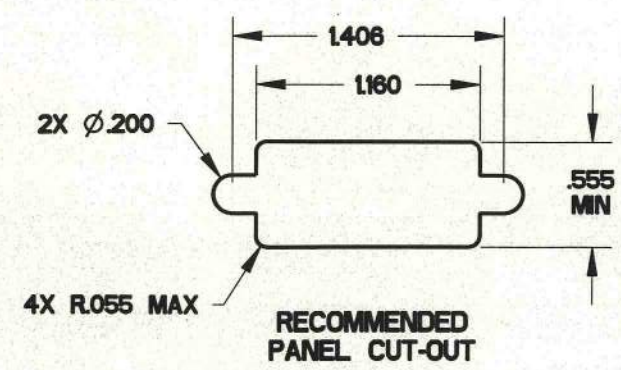
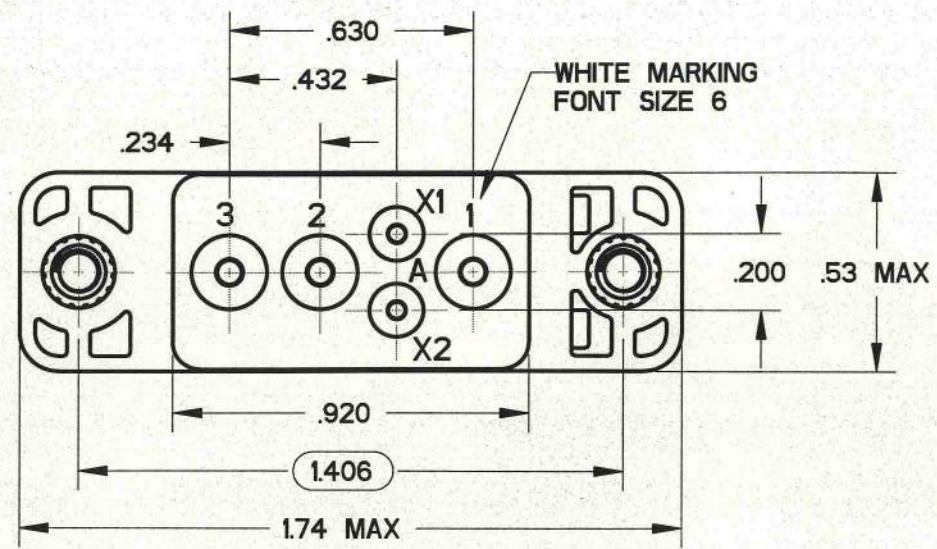

PART NUMBER TABLE

APCD P/N	HARDWARE PACKAGE	CONTACTS SUPPLIED
JRS500100	NONE	NONE
JRS500101	NONE	YES
JRS500110	YES	NONE
JRS500111	YES	YES

- NOTES:
- MATERIALS:  
 HOUSING: POLYETHERIMIDE PER ASTM-D5205  
 GROMMET: SILICONE RUBBER PER A-A-59588  
 THREADED INSERT: STAINLESS STEEL
  - OPERATING RANGE:  
 TEMPERATAURE: -65 °C TO 125 °C  
 INSULATION RESISTANCE: 1000 MEGOHMS MIN.  
 DIELECTRIC WITHSTANDING VOLTAGE: 1500 VRMS AT SEA LEVEL AND 500 VRMS AT 80,000 FT. ALTITUDE  
 VIBRATION: MIL-STD-202, METHOD 204, TEST CONDITION G  
 SHOCK: MIL-STD-202, METHOD 213, TEST CONDITION C
  - PART ACCEPTS M39029/92-533 AND M39029/92-535 SOCKET CONTACTS, SIZE 16/16 AND SIZE 12/12.

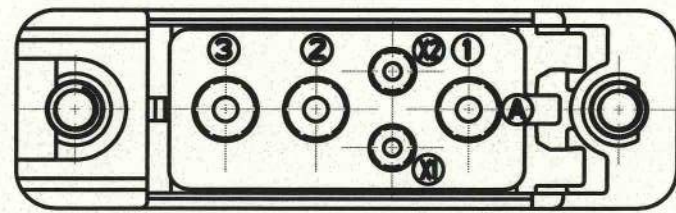

DIMENSIONS ANSI Y14.5M UNITS: INCHES Pro/E FILE	TOLERANCES .XX ±0.01 .XXX ±0.005 ANGLES ±2.0°	PROJECTION 	<b>Amphenol Pcd</b> SPECIFICATION DRAWING ENGR Frank.Li 07-Apr-08		TITLE SNAP-IN RELAY SOCKET 1 POLE 3 POS. SIZE 12, 2 POS. SIZE 16		
			ORIGINAL 	THIS DOCUMENT CONTAINS PROPRIETARY INFORMATION WHICH IS THE CONFIDENTIAL PROPERTY OF AMPHENOL PCD INC., BEVERLY, MA		CHKD  5/29/09 APPD  5-29-09	SIZE B DWG NO. JRS500100 CODE: 58982

JRS500100

JRS500100